

**2 PIECES BALL VALVE PN16/40 FLANGED JC RANGE
SHORT PATTERN (DIN 3202-1 F4/F5)**



ISO 9001 : 2015
BUREAU VERITAS
Certification



ISO 14001:2015
BUREAU VERITAS
Certification



PED/2014/68/UE
BUREAU VERITAS
Certification



Certificate 3.1



**JC
VALVES**



FIRE SAFE



Size : DN 15 to 300 mm
Ends : PN16/40 R.F. Flanges
Min Temperature : -20°C
Max Temperature : + 260°C
Max Pressure : 40 Bars up to DN50, 16 Bars over
Specifications : ISO 5211 mounting pad
Fire safe according to ISO 10497 : 2004, API 607
5th, BS 6755 Part 2 and API 6FA
Fugitive emissions EN 15848-1:2006 and TALUFT
Atex, PTFE filled with 20% graphite seat

Materials : Carbon steel ASTM A216 WCB

*the installation defects and wear defects are not covered by the guarantee

Sferaco 90 rue du Ruisseau 38297 St Quentin Fallavier Tel: + 33 (0) 474.94.15.90 Fax: + 33 (0) 474.95.62.08 Internet: www.sferaco.fr E-mail: sferaco@sferaco.fr

**2 PIECES BALL VALVE PN16/40 FLANGED JC RANGE
SHORT PATTERN (DIN 3202-1 F4/F5)**

SPECIFICATIONS :

- Full bore
- Anti blow-out stem
- PTFE filled with 20% graphite seat
- Locking device on request
- ISO 5211 mounting pad
- 2 pieces type (Split body)
- PN40 Flanges R.F. up to DN50, PN16 over
- Antistatic device
- Fire safe ISO 10497 : 2004, API 607 5th, BS 6755 Part.2 and API 6FA
- Fugitive emissions EN 15848-1 : 2006 and TA LUFT VDI 2440
- Graphite packing + FKM O ring on stem
- With exhaust hole in the ball (located in the top of the ball to avoid overpressure in it)
- Trunnion mounted hollow ball over DN200

USE :

- Chemical industries, petrochemical industries, hydraulic installation, heating, water distribution, compressed air
- Min and max Temperature Ts : -20°C to + 260°C
- Max Pressure Ps : 40 bars up to DN50, 16 bars over (see graph)
- Vacuum 10⁻² torr
- Compressed air (ambient temperature) : 16 bars maximum
- Steam : 14 bars maximum

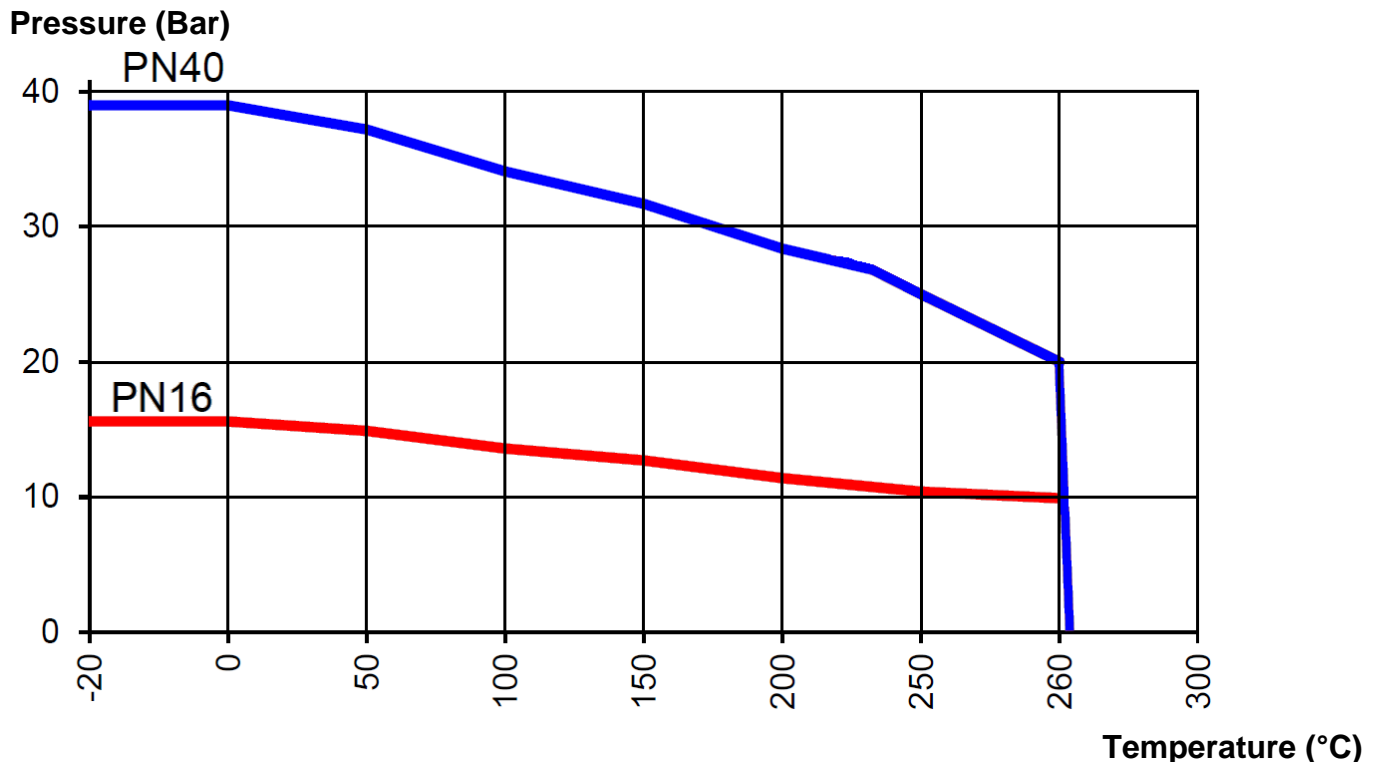
PRESSURE / TEMPERATURE GRAPH (STEAM EXCLUDED) :

**2 PIECES BALL VALVE PN16/40 FLANGED JC RANGE
SHORT PATTERN (DIN 3202-1 F4/F5)**

FLOW COEFFICIENT Kvs (in m³ / h) :

DN	15	20	25	32	40	50	65	80	100	125	150	200	250	300
Kvs (m ³ / h)	20	40	75	130	170	270	550	1000	1650	3000	4200	9000	15000	20800

TORQUE VALUE (in Nm without safety coefficient) :

DN	BTO*	RTO	ETO	BTC	RTC	ETC*	MAST	Ps (bars)
15	13,2	7,2	8,4	9,6	7,2	10,8	26	40
20	16,8	8,4	9,6	13,2	8,4	13,2	26	40
25	24	12	14,4	18	12	19,2	26	40
32	30	15,6	18	22,8	15,6	24	69	40
40	39,6	20,4	24	30	20,4	31,2	85	40
50	55,2	27,6	33,6	42	27,6	44,4	85	40
65	73,2	37,2	44,4	55,2	37,2	58,8	176	16
80	116,4	58,8	69,6	87,6	58,8	93,6	246	16
100	159,6	80,4	96	120	80,4	127,2	305	16
125	271,2	135,6	163,2	204	135,6	217,2	607	16
150	384	192	230,4	288	192	307,2	974	16
200	832,8	416,4	499,2	625,2	416,4	666	1387	16
250	1344	672	806,4	1008	672	1075,2	1387	16
300	1800	900	1080	1350	900	1440	2541	16

RANGE :

- Carbon steel body ball valve with handle flanged PN40 Ref. 540AICG from DN 15 to DN 50
- Carbon steel body ball valve with handle flanged PN16 Ref. 516AICG from DN 65 to DN 150
- Carbon steel body ball valve with free stem PN16 Ref. 516AICG DN200
- Carbon steel body ball valve with free stem PN16 Ref. 1516AICG from DN250 to 300

ENDS:

- PN40 Flanges R.F. up to DN50, PN16 over

**2 PIECES BALL VALVE PN16/40 FLANGED JC RANGE
SHORT PATTERN (DIN 3202-1 F4/F5)**

ACCESSORIES :



- Locking device DN 15-200 Ref.9830130-9830138



- Reinforced locking device DN 15-200 Ref.9830120-9830129



- Stainless steel handle DN 15-150 Ref. 9830513-9830520



- Oval stainless steel handwheel DN 15-50 Ref.9830575-9830577



- Gearbox DN 125-300 Ref. 9830397-9830401



- Single stainless steel stem extension DN 15-200 Ref. 9810615-9810623

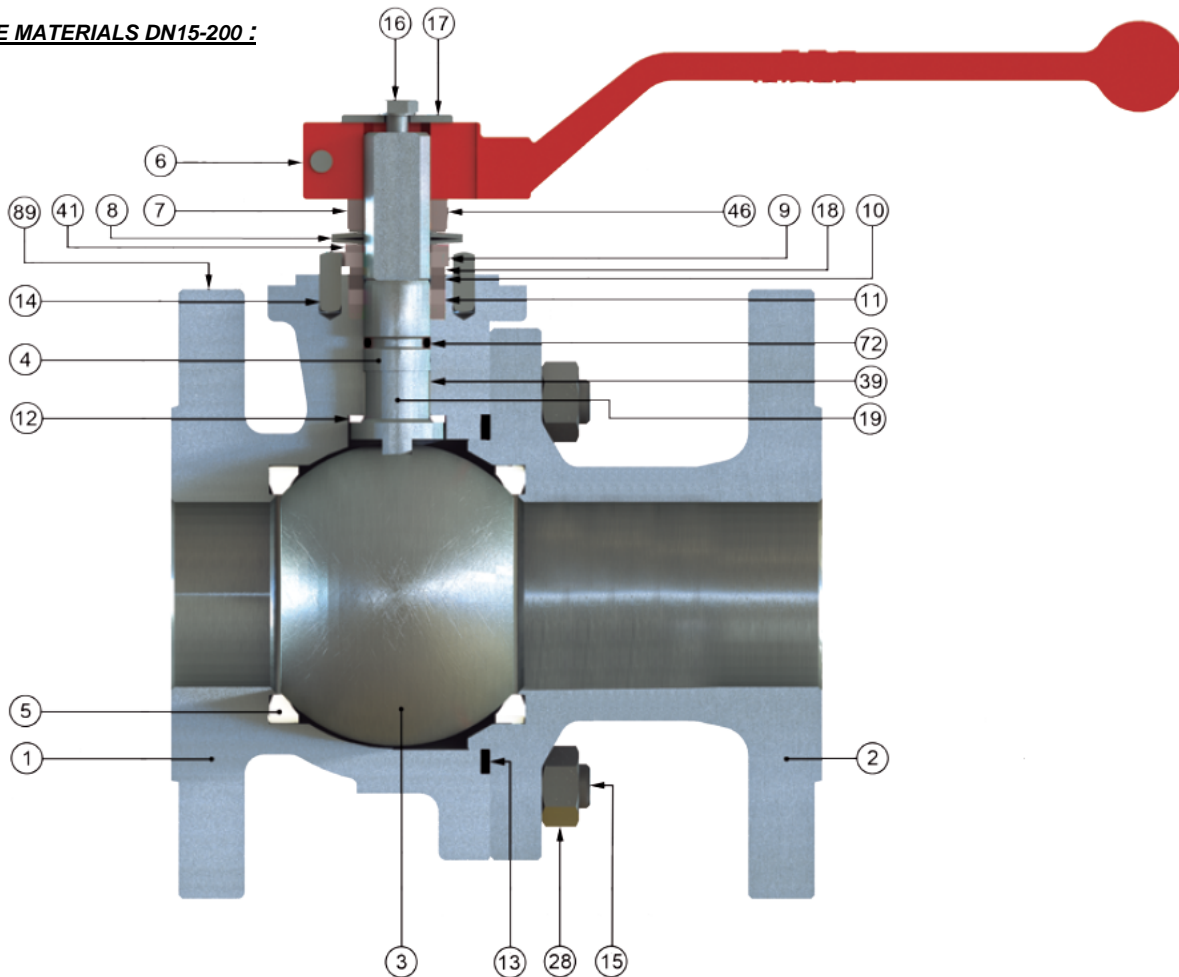

- ISO 5211 carbon steel stem extension DN 15-100 Ref. 9810624-9810627
- ISO 5211 stainless steel stem extension DN 15-100 Ref. 9810628-9810631

**2 PIECES BALL VALVE PN16/40 FLANGED JC RANGE
 SHORT PATTERN (DIN 3202-1 F4/F5)**
VALVE MATERIALS DN15-200 :

Item	Designation	Materials	Item	Designation	Materials
1	Body	ASTM A216 WCB 1.0619	13	Body spiral seat	AISI 316L + PTFE + Graphite
2	Ends		14	Pin	Carbon Steel
3	Ball DN15-25	ASTM A479 Tp.316	15	Screw (stud DN32-100)	DIN 933 8.8 zinc dichrom.
	Ball DN 32-200	Inox ASTM A 351 CF8M	16	Handle screw	DIN 933 A4-70
4	Stem	ASTM A479 Tp.316	17	Washer	Zinc plated carbon steel
5	Seat	PTFE filled with 20% graphite	18	Thrust washer	PTFE filled with 25% glass
6	Handle	Ductile iron	19	Antistatic device	Stainless steel
7	Packing nut	Carbon Steel	28	Nut (DN32-100)	DIN 934 8.8 zinc dichrom.
8	Elastic ring	Carbon Steel	39	Stem bushing (DN25-200)	PTFE filled with 25% glass
9	Stop washer	Carbon Steel	41	Spacer (DN40-200)	Carbon Steel
10	Packing gland	AISI 303	46	Washer	AISI 304
11	Packing	Graphite	72	O ring	FKM
12	Gasket	PTFE filled with 25% glass	89	ID plate	Stainless steel

**2 PIECES BALL VALVE PN16/40 FLANGED JC RANGE
SHORT PATTERN (DIN 3202-1 F4/F5)**

VALVE MATERIALS DN 250-300 :

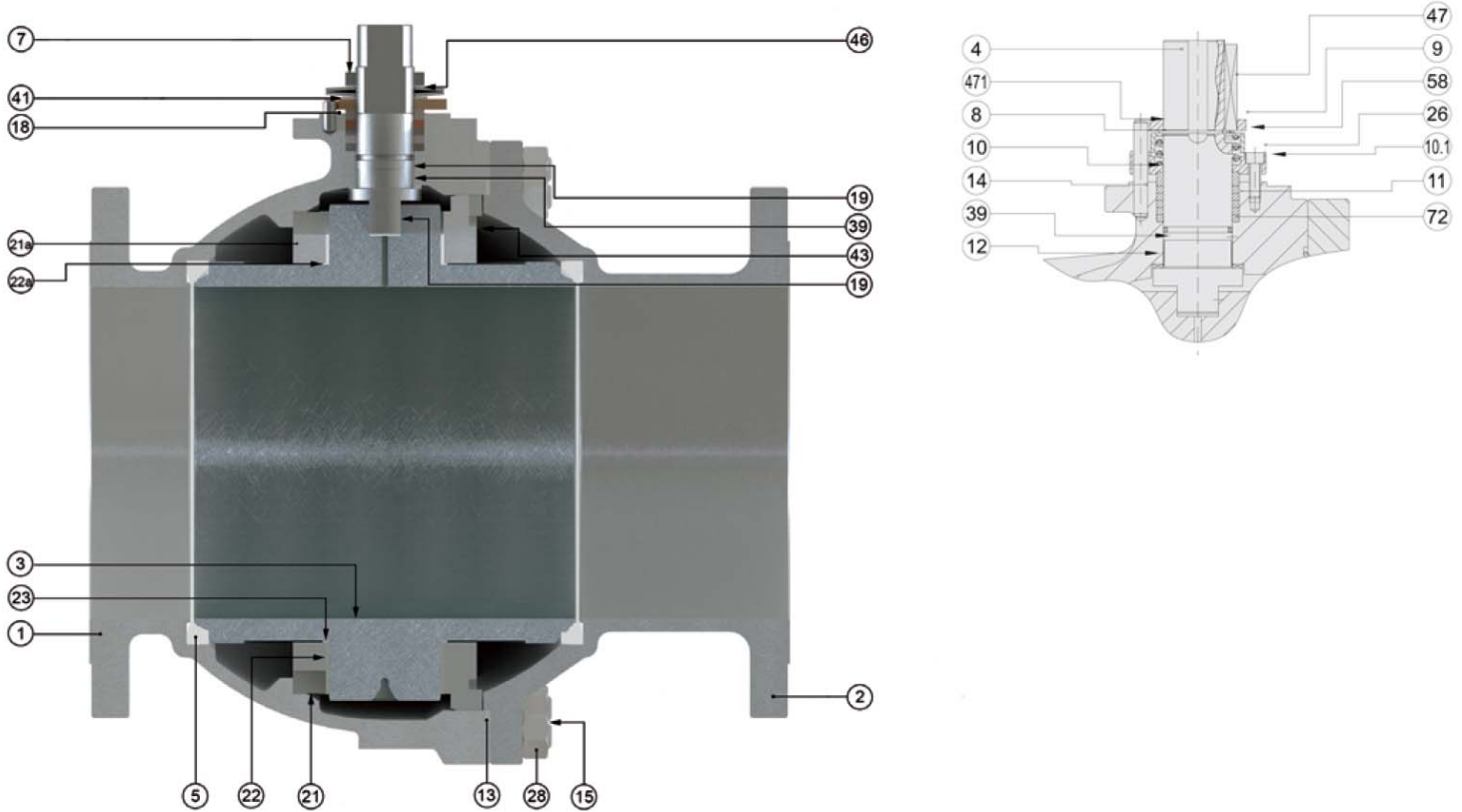

Item	Designation	Materials
1	Body	ASTM A216 WCB 1.0619
2	Ends	
3	Ball	ASTM A 351 CF8M
4	Stem	ASTM A479 Tp.316
5	Seat	PTFE filled with 20% graphite
7	Packing gland	Zinc plated carbon steel
8	Elastic washer	Carbon steel
9	Pin	
10	Gland	AISI 303
10.1	Ring	
11	Packing	Graphite
12	Gasket	PTFE filled with 25% glass
13	Body seat	AISI 316L + Graphite
14	Stop pin	Carbon steel
15	Stud	DIN 933 A4-70

Item	Designation	Materials
18	Bushing	PTFE filled with 25% glass
19	Antistatic device	Stainless steel
21/21a	Ball trunnion	ASTM A 351 CF8M
22/22a	Trunnion bearing	PTFE + 50% Stainless steel
23	Bearing	PTFE
26	Bolt	DIN 912 8.8 zinc plated
28	Nut (only for DN250)	DIN 934 8 Zinc plated
39	Stem bushing	PTFE + 50% Stainless steel
41	Spacer	Carbon steel
43-47	Key	AISI 316
46	Locking washer	AISI 304
58	Spring protection	Carbon steel
72	O ring	FKM
89	ID plate	Stainless steel
471	Retainer	Carbon steel

**2 PIECES BALL VALVE PN16/40 FLANGED JC RANGE
SHORT PATTERN (DIN 3202-1 F4/F5)**

GEARBOX MATERIALS :

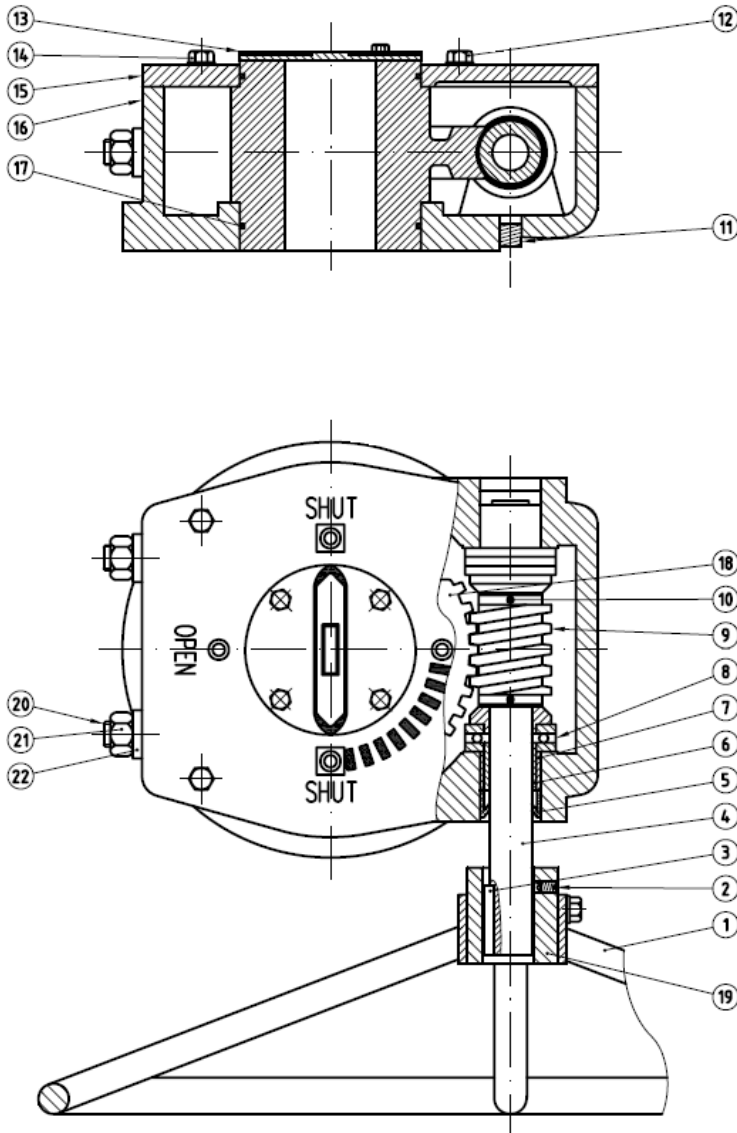

Item	Designation	Materials
1	Handwheel	Carbon steel
2	Screw	
3	Stem key	
4	Input shaft	AISI 1045
5	Oil seal	Rubber
6	Bearing	Cu Base Alloy
7	Oil bearing	
8	Thrust bearing	Carbon steel
9	Worm	AISI 1045
10	Pin	Carbon steel
11	Plug	
12	Screw	
13	Indicator plate	Cast iron
14	Screw	Carbon steel
15	Cover	Cast iron
16	Housing	
17	O ring	Rubber
18	Worm gear	Ductile iron
19	Nut	Carbon steel
20	Stop screw	
21	Nut	
22	Hex nut	
23-24	Spur gear cover+housing	Cast iron
25	Seal cover	Rubber
26-27-28	Screw+washer	Carbon steel
29	Gear	
30	Bearing	Cu Base Alloy
31	Bolt	Carbon steel
32	Slotted spring pin	
33	Spur gear	
34	Locator pins	

**2 PIECES BALL VALVE PN16/40 FLANGED JC RANGE
 SHORT PATTERN (DIN 3202-1 F4/F5)**

VALVE SIZE DN15-200 (in mm) :

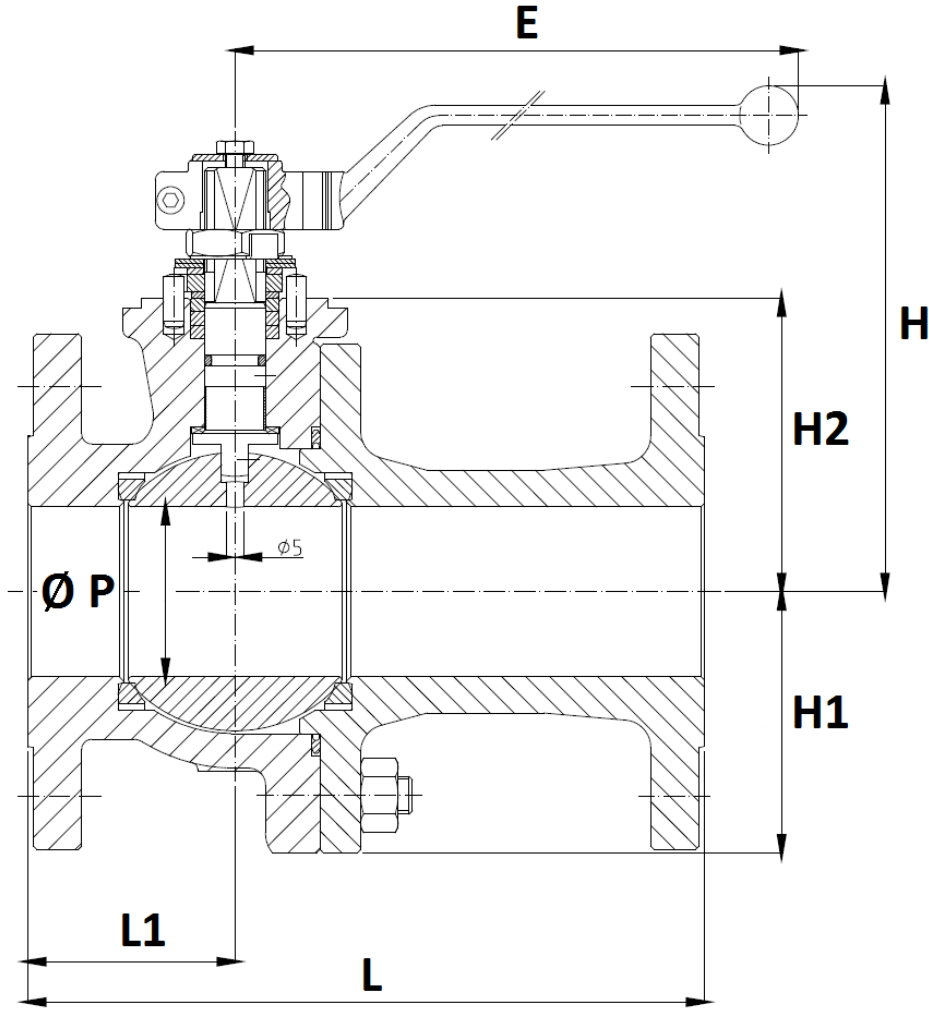

DN	15	20	25	32	40	50	65	80	100	125	150	200*
Ø P	15	20	25	32	40	50	65	80	100	125	151	203
L	115	120	125	130	140	150	170	180	190	325	350	400
L1	53	52	48.5	54	55	61	75.5	82	90.5	120	135	200
E	164	164	164	210	213	213	348	445	495	698	698	868
H	111	118	130	131	148	155	169	207	232	265	298	353
H1	-	-	-	-	-	-	-	-	118	138	160	208
H2	46	53	58	66.5	76	83.5	97	111	133	156	183	233
Weight (Kg)	2.8	3.6	5	7	9	12	16	22	32	52.5	76	111

* Handle on request for DN200 (free stem in standard)

**2 PIECES BALL VALVE PN16/40 FLANGED JC RANGE
SHORT PATTERN (DIN 3202-1 F4/F5)**

VALVE SIZE DN 250-300 (in mm) :

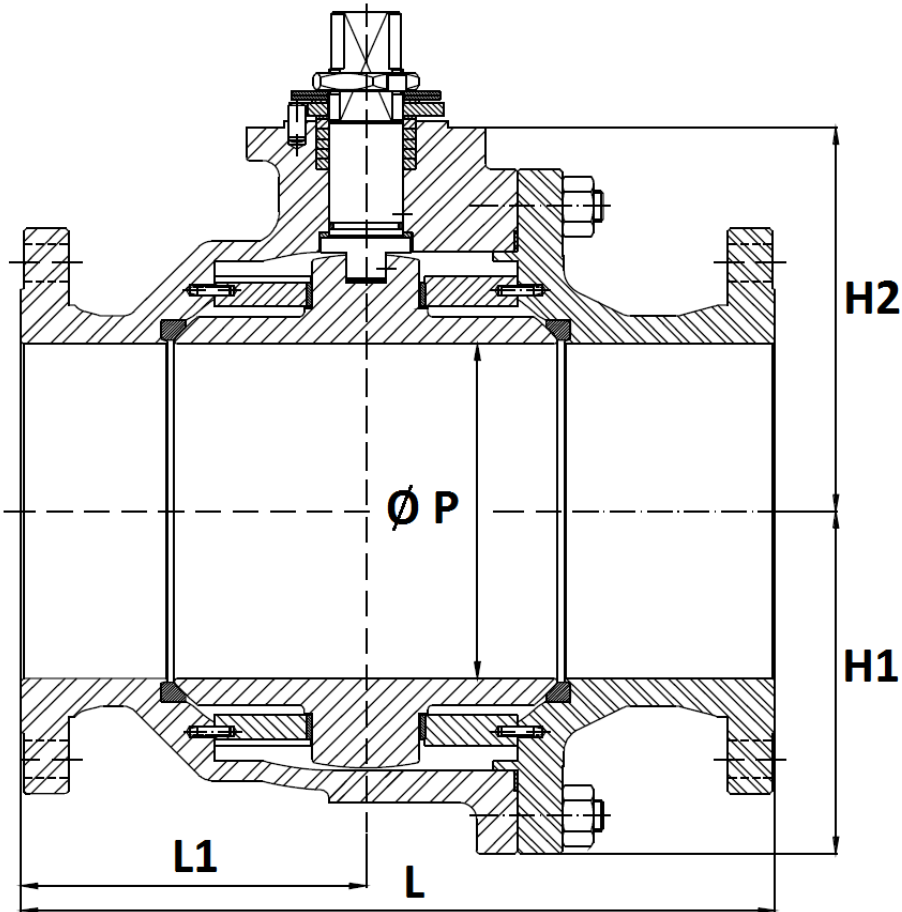

DN	250	300
Ø P	254	305
L	450	500
L1	225	245
H1	239	288
H2	256	297
Weight (in Kg)	223	323

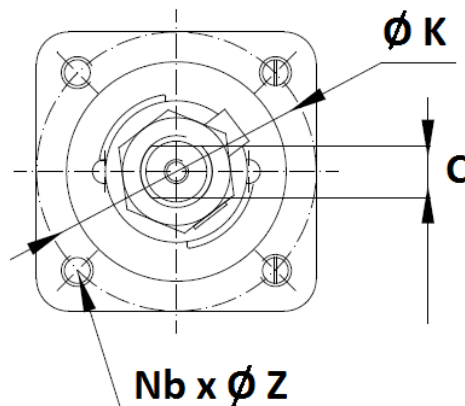
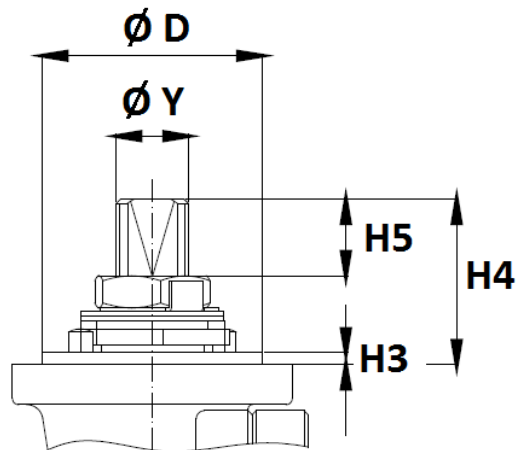
**2 PIECES BALL VALVE PN16/40 FLANGED JC RANGE
 SHORT PATTERN (DIN 3202-1 F4/F5)**
ISO MOUNTING PAD AND STEM SIZE DN15-200 (in mm) :

DN	15	20	25	32	40	50	65	80	100	125	150	200
H3	1.5				3							4
H4	11.2	14.7	22.7	32	41.5	41.5	44	44.5	56.5	56	68	72
H5	5	8.5	9.5	13	18.3	18.3	18.6	18.6	27.8	24.7	37.1	36.5
C	9	9	9	12	13	13	16	18	20	25	29	32
Ø Y	M12x1.5			M16x1.5	M18x1.5		M22x1.5	M25x1.5	M28x1.5	M35x2	M40x2	M45x2
Ø D	35				55			70		85		100
Ø K	50	50	50	50	70	70	70	102	102	125	125	140
ISO	F05	F05	F05	F05	F07	F07	F07	F10	F10	F12	F12	F14
N x Ø Z	4 x M6	4 x M6	4 x M6	4 x M6	4 x M8	4 x M8	4 x M8	4 x M10	4 x M10	4 x M12	4 x M12	4 x M16

**2 PIECES BALL VALVE PN16/40 FLANGED JC RANGE
SHORT PATTERN (DIN 3202-1 F4/F5)**

ISO MOUNTING PAD AND STEM SIZE DN250-300 (in mm) :

DN 250

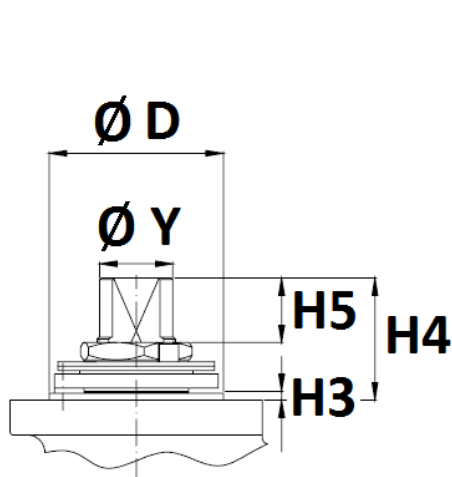

DN300

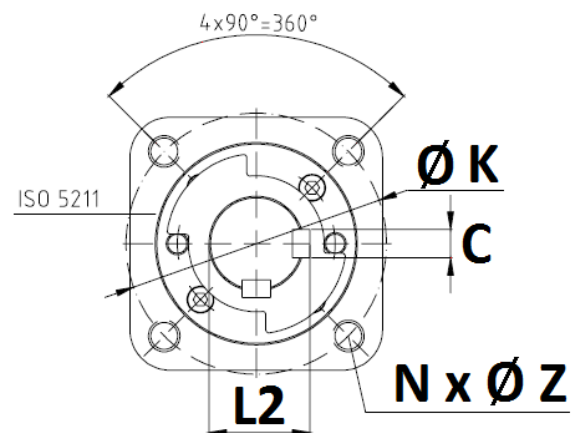
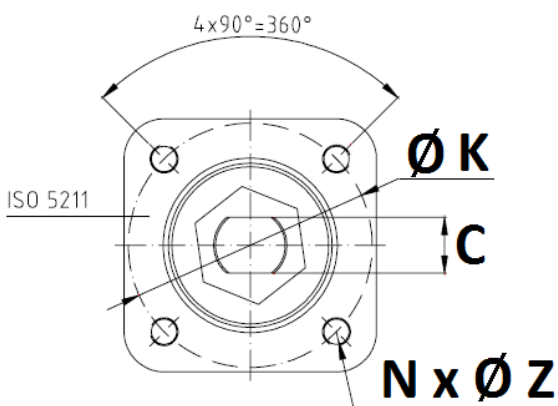
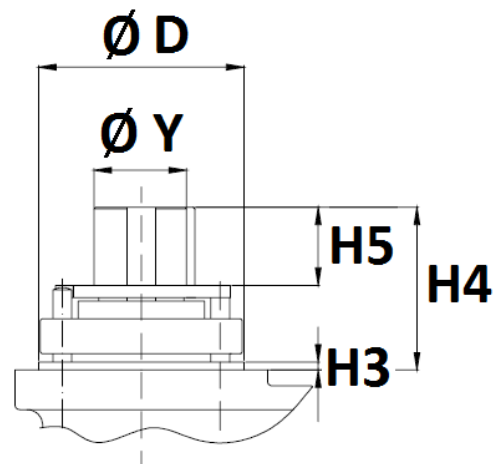

DN	250	300
H3	4	4
H4	72	106
H5	36.5	58
L2	-	53.5
C	32	14
Ø Y	M45x2	Ø50
Ø D	100	100
Ø K	140	140
ISO	F14	F14
N x Ø Z	4 x M16	4 x M16

**2 PIECES BALL VALVE PN16/40 FLANGED JC RANGE
 SHORT PATTERN (DIN 3202-1 F4/F5)**

GEARBOX SIZE DN125-300 (in mm) :

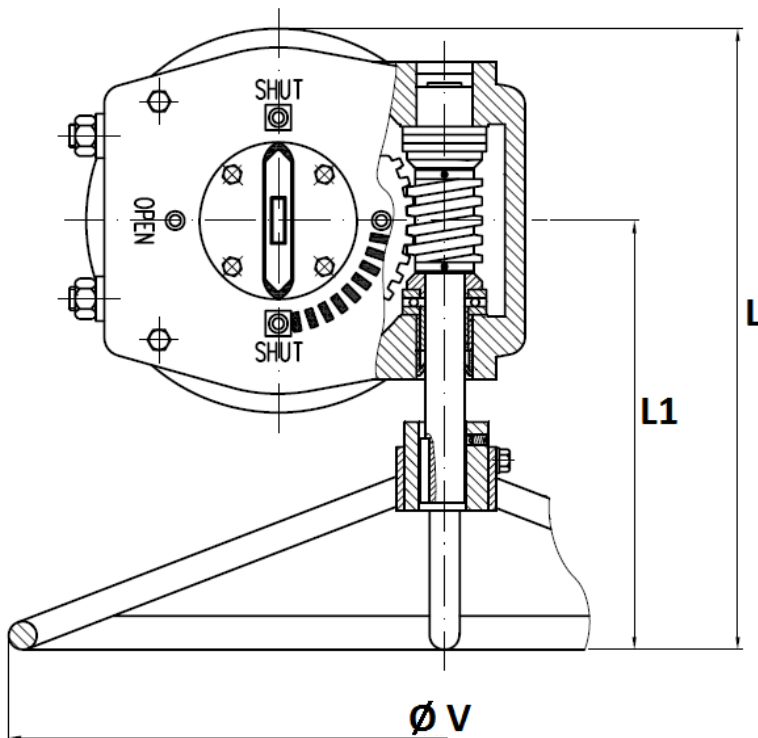
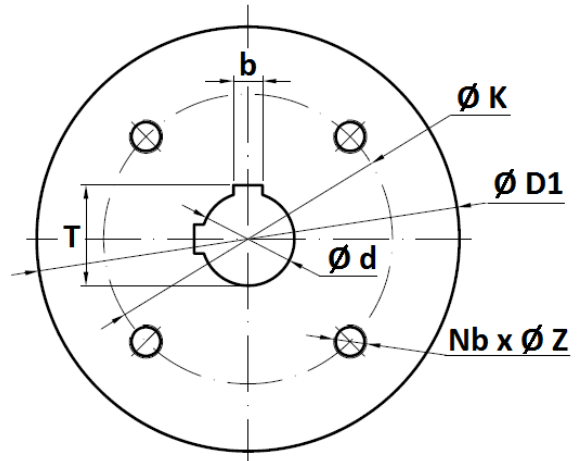
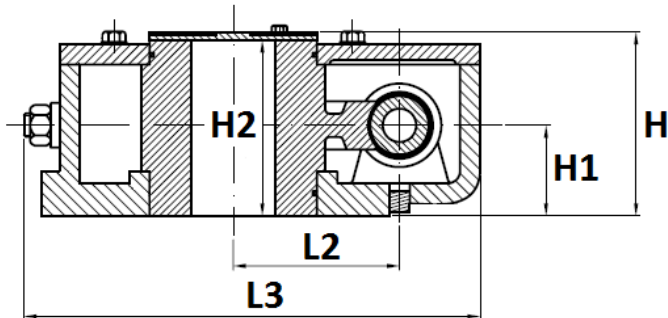

DN	125-150-200	250	300
Ø V	465	600	600
L	331.5	487	544
L1	229	370	402
L2	77.5	90	126
L3	245	282	312
H	107	107	113.5
H1	55	55	65
H2	85	85	90
Ø d	45	65	80
Ø D1	205	254	290
Ø K	140	140	165
ISO	F14	F14	F16
Nb - Ø Z	4-M16x20	4-M16x20	4-M20x25
b	14	18	22
T	48.6	69.3	85.6
Weight (Kg)	17.8	22.5	36
Torque (Nm)	1200	2000	3300

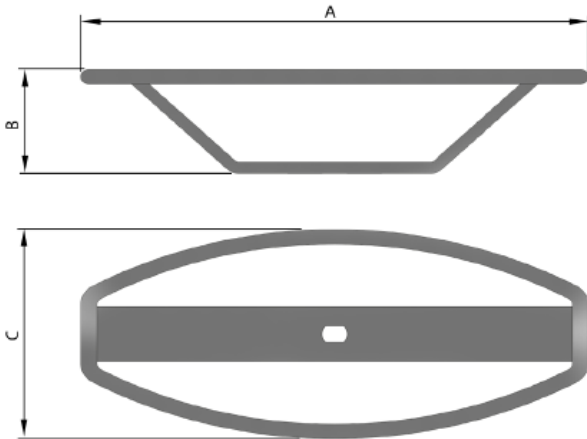
**2 PIECES BALL VALVE PN16/40 FLANGED JC RANGE
 SHORT PATTERN (DIN 3202-1 F4/F5)**
OVAL HANDWHEEL SIZE DN15-50 (in mm) :

DN	15	20	25	32	40	50
A	160	160	160	200	216	216
B	54	54	54	56	57	57
C	75	75	75	90	100	100
Weight (Kg)	0.25	0.25	0.25	0.5	0.55	0.55
Ref.	9830575			9830576	9830577	

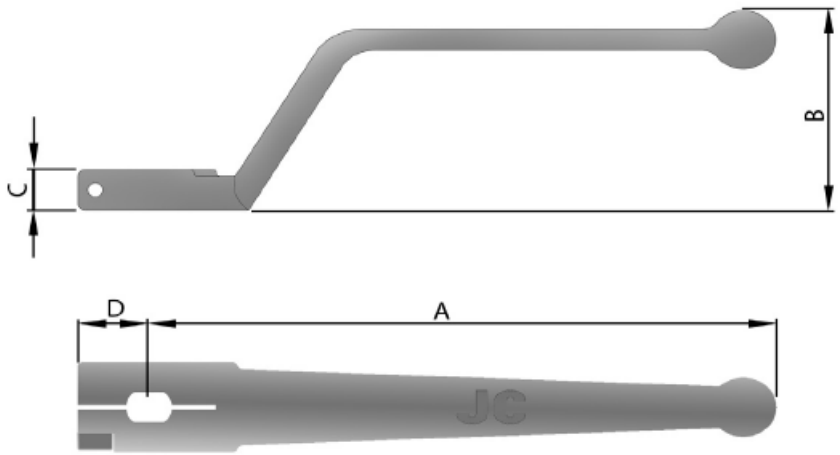
STAINLESS STEEL HANDLE SIZE DN15-200 (in mm) :

DN	15	20	25	32	40	50	65	80	100	125	150	200
A	163.5		300		212.5		347.5	445	495	697.5		867.5
B	58.5		45		48.5		46.5	70	70	77.5	84.5	84.5
C	12		16		21		20		29	30	40	
D	18.5		22		25.5			33		47		55
Weight (Kg)	0.2		0.3		0.53		0.63	1.52	1.85	2.95	3.4	4.6
Ref.	9830513		9830514		9830515		9830516	9830517	9830518	9830519	9830520	

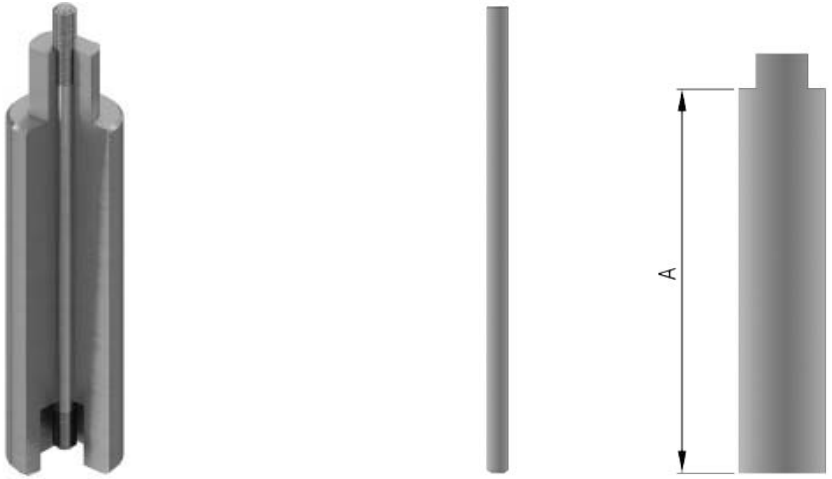
**2 PIECES BALL VALVE PN16/40 FLANGED JC RANGE
 SHORT PATTERN (DIN 3202-1 F4/F5)**
SINGLE STAINLESS STEEL STEM EXTENSION SIZE DN15-200 (in mm) :

DN	15	20	25	32	40	50	65	80	100	125	150	200
A	100											
Weight (Kg)	0.25		0.57		0.56		0.78	1.03	1.42	1.67	2.25	2.97
Ref.	9810615		9810616		9810617		9810618	9810619	9810620	9810621	9810622	9810623

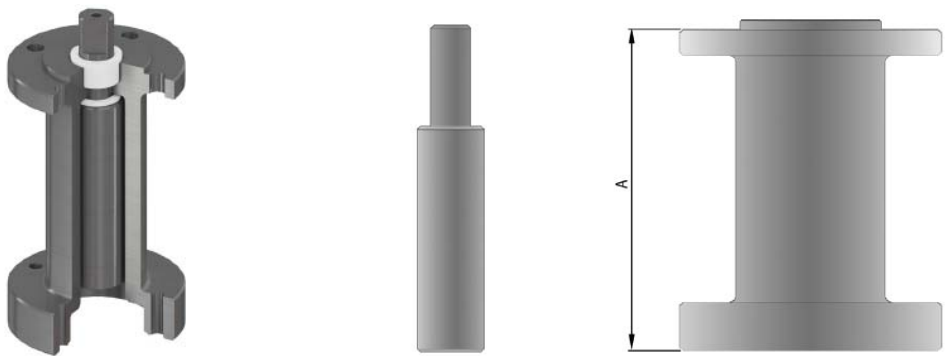
STANDARD ISO 5211 STEM EXTENSION (CARBON AND STAINLESS STEEL) DN15-100 (mm) :

DN	15	20	25	40	50	80	100
A	100						
Weight (Kg)	1.24			2.63		4.78	4.18
Ref. Steel	9810624			9810625		9810626	9810627
Ref. St.steel	9810628			9810629		9810630	9810631

 Sferaco 90 rue du Ruisseau 38297 St Quentin Fallavier Tel: + 33 (0) 474.94.15.90 Fax: + 33 (0) 474.95.62.08 Internet: www.sferaco.fr E-mail : sferaco@sferaco.fr

**2 PIECES BALL VALVE PN16/40 FLANGED JC RANGE
SHORT PATTERN (DIN 3202-1 F4/F5)**

FLANGES SIZE (in mm) :

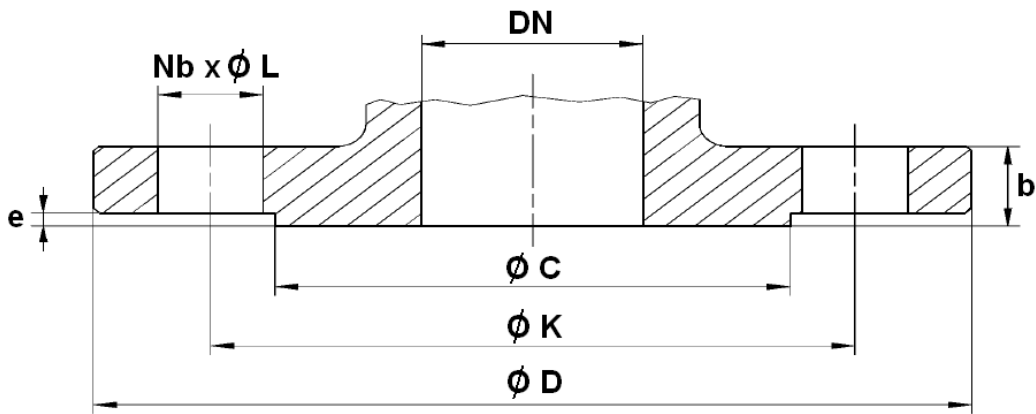

DN	15	20	25	32	40	50	65	80	100	125	150	200	250	300
Ø C	45	58	68	78	88	102	122	138	158	188	212	268	323.8	381
Ø D	95	105	115	140	150	165	185	200	220	250	285	340	405	460
Ø K	65	75	85	100	110	125	145	160	180	210	240	295	320	378
Nb x Ø L	4 x 14	4 x 14	4 x 14	4 x 18	4 x 18	4 x 18	4 x 18	8 x 18	8 x 18	8 x 18	8 x 22	12 x 22	12 X 26	12 X 26
b	16	18	18	18	18	20	18	20	20	22	22	24	26	28
e	2	2	2	2	3	3	3	3	3	3	3	3	3	4

**2 PIECES BALL VALVE PN16/40 FLANGED JC RANGE
SHORT PATTERN (DIN 3202-1 F4/F5)****STANDARDS :**

- Fabrication according to ISO 9001:2015 and ISO 14001 : 2015
- DIRECTIVE 2014/68/EU : CE N° 0056
Risk Category IV module H1
- Certificate 3.1 on request
- Valve designing according to EN 1983 – ISO 17292 and EN 12516
- Pressure Tests according to EN 12266-1, Rate A
- Marking according to EN 19
- Fire safe according to ISO 10497 : 2004, API 607 5th, BS6755 Part 2, and API 6FA 1994
- Fugitive Emissions according to EN 15848-1 : 2006 B Class and TA LUFT VDI 2440
- SIL2 according to IEC/EN 61508, SIL 3 possible according to the type of installation
- Flanges R.F. type B1 according to EN 1092-1 PN16/40
- Shell finishing quality MSS SP 55
- ISO 5211 mounting pad
- Length according to EN 558 series 27 (DIN 3357-2 ff, DINI 3202-1 F4 up to DN100, F5 over)
- ATEX Group II Category 2 G/2Dc Zone 1 & 21 Zone 2 & 22 (optional marking) up to DN200 according to directive 2014/34/EU
- Russian certificate TRCU 10, TRCU 12 and TRCU 32 (EAC marking and declaration **on request**)

ADVICE : Our opinion and our advice are not guaranteed and SFERACO shall not be liable for the consequences of damages.
The customer must check the right choice of the products with the real service conditions.

**2 PIECES BALL VALVE PN16/40 FLANGED JC RANGE
SHORT PATTERN (DIN 3202-1 F4/F5)****INSTALLATION INSTRUCTIONS****GENERAL GUIDELINES :**

- Ensure that the valves to be used are appropriate for the conditions of the installation (type of fluid, pressure and temperature).
- Be sure to have enough valves to be able to isolate the sections of piping as well as the appropriate equipment for maintenance and repair.
- Ensure that the valves to be installed are of correct strength to be able to support the capacity of their usage.
- **Installation of all circuits should ensure that their function can be automatically tested on a regular basis (at least two times a year).**

INSTALLATION INSTRUCTIONS :

- **Before installing the valves, clean and remove any objects from the pipes** (in particular bits of sealing and metal) which could obstruct and block the valves.
- **Ensure that both connecting pipes either side of the valve (upstream and downstream) are aligned (if they're not, the valves may not work correctly).**
- **Make sure that the two sections of the pipe (upstream and downstream) match, the valve unit will not absorb any gaps. Any distortions in the pipes may affect the tightness of the connection, the working of the valve and can even cause a rupture.** To be sure, place the kit in position to ensure the assembling will work.
- **If sections of piping do not have their final support in place, they should be temporarily fixed. This is to avoid unnecessary strain on the valve.**
- Tighten the bolts in cross.
- It's recommended to operate the valve (open and close) 1 to 2 times per year