

HIGH PRESSURE 3 WAYS BALL VALVE

ISO 9001:2008

BUREAU VERITAS
Certification



Size : DN 1/4" to 1"
Ends : Threaded Female BSP
Min Temperature : -10°C
Max Temperature : + 100°C
Max Pressure : 350 – 400 Bars
Specifications : Reduced Bore
High pressure
L port

Materials : Galvanized steel

HIGH PRESSURE 3 WAYS BALL VALVE

SPECIFICATIONS :

- Reduced bore
- Galvanized steel
- High pressure
- L port
- Hydraulic type

USE :

- Hydraulic applications
- Min and max Temperature Ts : -10°C to + 100°C
- Max Pressure Ps : 400 bars DN1/4" to 3/8" and 350 bars over (see graph)

PRESSURE / TEMPERATURE GRAPH (STEAM EXCLUDED) :

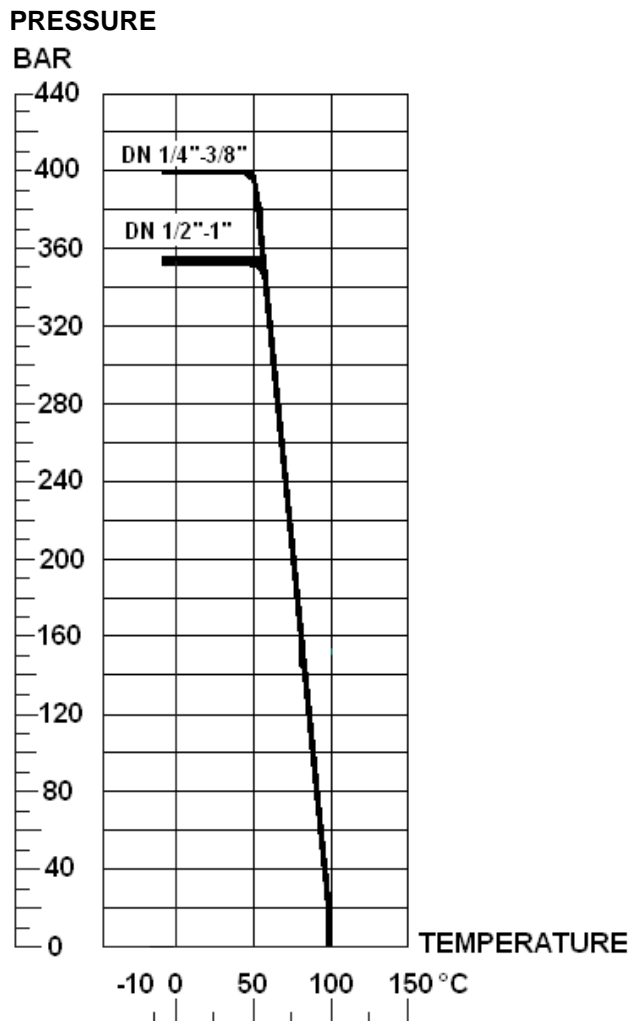

HIGH PRESSURE 3 WAYS BALL VALVE

RANGE :

- Galvanized steel with L port **Ref. 721** DN 1/4" to 1"

ENDS :

- Threaded cylindrical female BSP

MATERIALS :

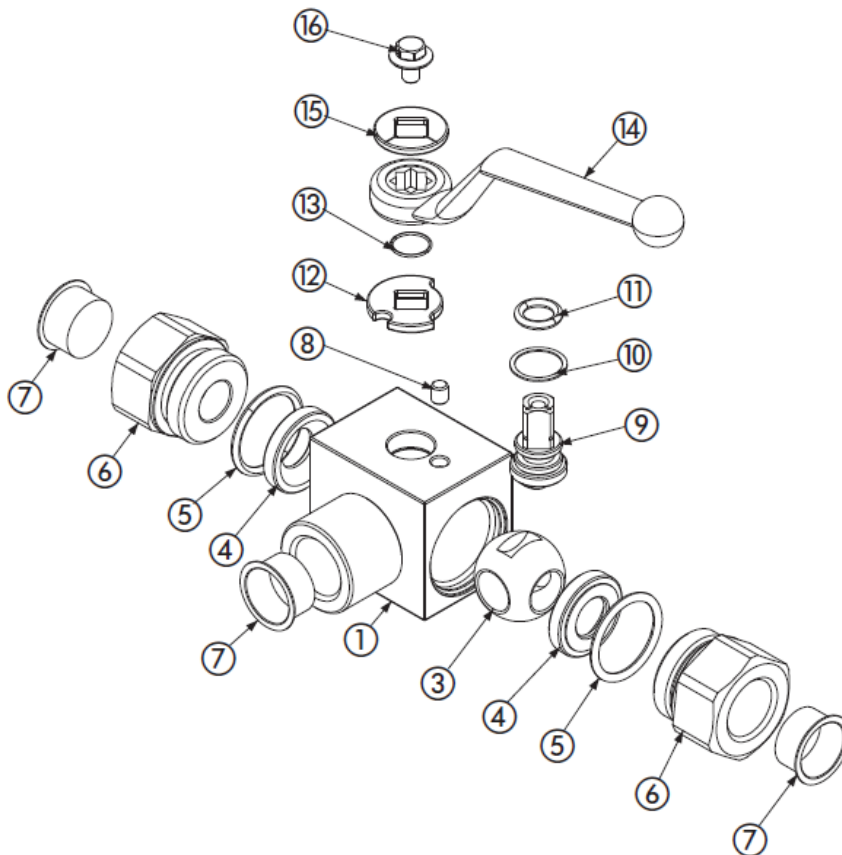

Item	Designation	Materials
1	Body	Galvanized 1.0737 steel
3	Ball	Chromed1.0737 steel
4	Seat	POM
5	O-ring	NBR
6	Ends	Galvanized 1.0737 steel
7	Caps	PVC
8	Spine	Steel 1.0737
9	Stem	Steel 1.0737
10	Stem seal	POM
11	O-ring	NBR
12	Washer	Steel 1.0116
13	Seeger	Steel 1.4301
14	Handle	Aluminium
15	Handle washer	Steel 1.0116
16	Handle screw	Steel DIN 6921 8.8

HIGH PRESSURE 3 WAYS BALL VALVE

SIZE (in mm) :

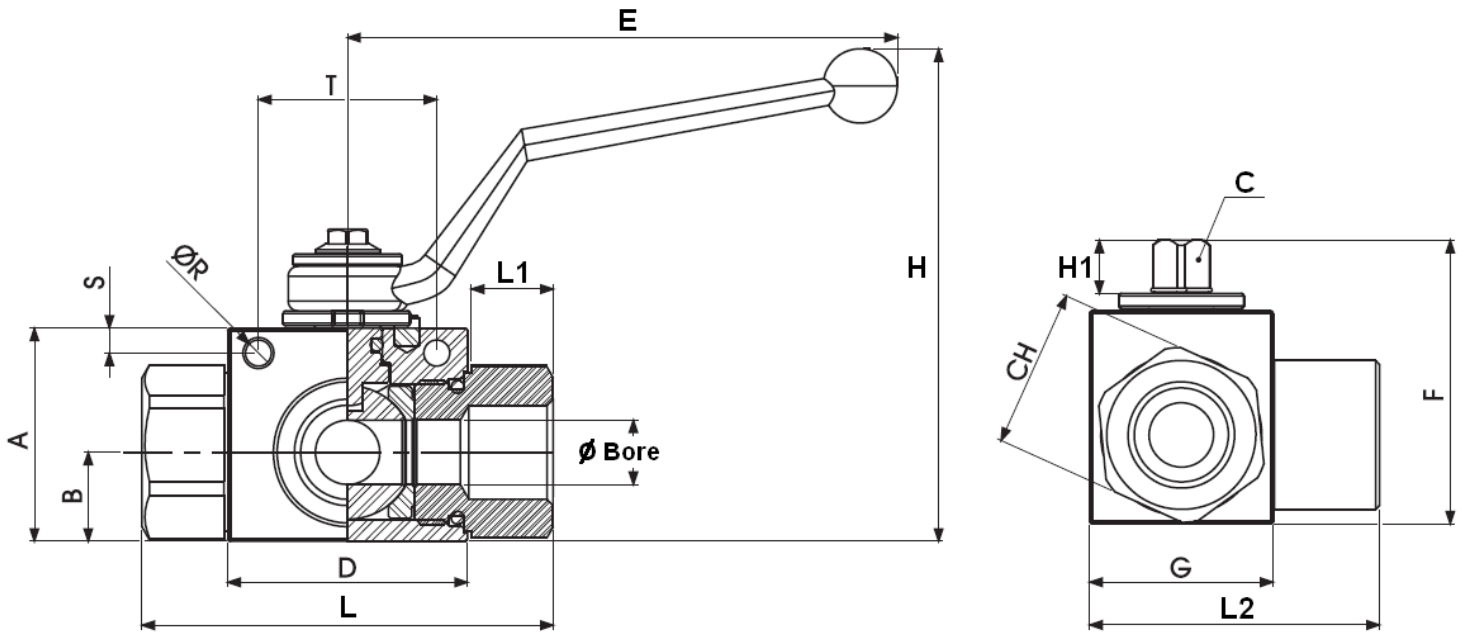

Stem size :

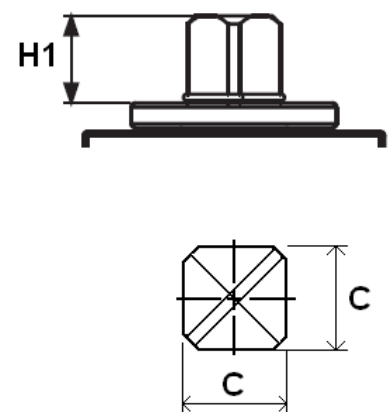

Ref.	DN	1/4"	3/8"	1/2"	3/4"	1"
721	Ø Bore	6	10	13	20	25
	L	71	73	83	95	112
	L1	15.5	15.5	17	21	24
	L2	48.5	54.5	58.5	75	87.5
	E	110	110	110	180	180
	H	91.5	96.5	99.5	106.5	116.5
	H1	11	11	11	14	14
	A	35	40	43	55	65
	B	14.5	17.4	18	23.4	29.5
	C	9	9	9	14	14
	CH	24	30	32	41	50
	D	42.4	44.4	48.4	62.5	66.5
	F	49	54.25	57	73.5	83.5
	G	30	35	37	45	55
	Ø R	5.25	5.25	5.25	6.25	6.25
	S	4.5	4.5	5	6	6
	T	34	34	36	50	50
Weight (Kg)	0.536	0.695	0.825	1.58	2.42	

HIGH PRESSURE 3 WAYS BALL VALVE

TORQUE VALUES (in Nm without safety coefficient) :

DN	1/4"	3/8"	1/2"	3/4"	1"
Torque (Nm)	16	18	25	45	72

STANDARDS :

- Fabrication according to ISO 9001 : 2008
- DIRECTIVE 2014/68/EU : Products excluded from directive (Article 4, § 3)
- Tests according to API 598
- Threaded cylindrical BSP ends according to ISO 228-1
- On request, ATEX Group II Category 2 G/2D Zone 1 & 21 Zone 2 & 22 (optional marking) according to directive 2014/34/UE

ADVICE : Our opinion and our advice are not guaranteed and SFERACO shall not be liable for the consequences of damages. The customer must check the right choice of the products with the real service conditions.

INSTALLATION AND MAINTENANCE

BEFORE INSTALLATION :

Pipe-line must be cleaned and free from residual of weldings, rubbish, shaving and every kind of extraneous materials. Pipe-line must be perfectly aligned and their support properly dimensioned so that there's no external constraint.

Please use the right product according to the services conditions to seal the valve.
Use the right bolt tightening so that the ends won't be damaged.

CLEANING AND TESTS

Keep closed the valves during the cleaning operation so that there's no impurities between the ball and the body.

Tests under pressure must be done with a cleaned pipe-line.

Open partially the valve for tests. Pressure test do not exceed the valve specifications according to API 598.

MAINTENANCE

It's recommended to operate the valve twice (open and close) 1 to 2 times per year.

When intervention on the valve, be sure there's no pressure in the pipe-line, there's no fluid in it, and that it is isolated. The temperature must be low enough to operate without risks. If there's a corrosive fluid, inert installation before intervention.