

**WAFER BUTTERFLY VALVE EXCELLENCE RANGE
WITH FOOD SILICONE SEAT AND POLISH STAINLESS STEEL DISC**



**BUREAU
VERITAS**

Marine & Offshore
Division



Lloyd's
Register

ISO 9001 : 2015



Lloyd's
Register

PED/2014/68/EU



Certificate 3.1

- Size :** DN 32 to 600 mm
- Ends :** Between flanges PN10/16 and Class 150 (PN20)
- Min Temperature :** - 40°C
- Max Temperature :** + 150°C
- Max Pressure :** 16 Bars up to DN300
- Specifications :** Long neck for isolation
Polish stainless steel disc
Full crossing stem
Food Silicone seat
ISO 5211 mounting pad

Materials : Ductile iron EN GJS 500-7, food silicone seat

*the installation defects and wear defects are not covered by the guarantee

**WAFER BUTTERFLY VALVE EXCELLENCE RANGE
WITH FOOD SILICONE SEAT AND POLISH STAINLESS STEEL DISC**

SPECIFICATIONS :

- Long neck for isolation
- ISO 5211 mounting pad
- Wafer type
- Between flanges PN10/16 from DN32/40 to 400 and Class 150 (PN20) from DN40 to 400 (over on request)
- Between flanges PN10 from DN450 to DN 600
- Full crossing stem
- Removable food silicone seat
- Polish stainless steel disc
- 9 positions lever with locking device up to DN200 , stop in all positions but non lockable from DN250 to 300
- Rilsan coated body color RAL 5024 , 250-300 microns thickness
- Stem extension 75 mm length (option)
- Square lever 30x30 mm for special key (option)

USE :

- High temperature, oil, acids, air or inerted gas, alimentary products
- Min and max Temperature Ts : - 40°C to + 150°C
- Max Pressure Ps : 16 bars up to DN300, 10 bars over (see graphs page 4)

RANGE :

- With lever from DN 32 to DN 300
- IP65 gear box possible (**Ref. 1197**) from DN 32 to DN 600
- IP65 chain gear box (**Ref. 1194**) from DN 32 to DN 500
- On request, stem extension with special length (**Ref. 98665**)
- On request, stainless steel handle and bolting **Ref. 9831250-9831264**

ENDS :

- Between flanges PN10/16 from DN32/40 to 400 and Class 150 (PN20) from DN40 to 400
- Between flanges PN10 from DN450 to DN 600

TORQUE VALUES (in Nm with safety coefficient of 30 % included) at 16 Bars :

DN	32/40	50	65	80	100	125	150	200	250	300
Torque (Nm)	9	11	20	29	47	82	130	210	360	475

TORQUE VALUES (in Nm with safety coefficient of 30 % included) at 10 Bars :

DN	32/40	50	65	80	100	125	150	200	250	300
Torque (Nm)	8	10	14	18	31	59	93	206	330	425

DN	350	400	450	500	600
Torque (Nm)	640	1176	1450	2150	2850

**WAFER BUTTERFLY VALVE EXCELLENCE RANGE
 WITH FOOD SILICONE SEAT AND POLISH STAINLESS STEEL DISC**

FLOW COEFFICIENT Kv (m³ / h) :

DN	Opening Angle								
	10°	20°	30°	40°	50°	60°	70°	80°	90°
32-40	3	5	10	16	22	31	36	36	36
50	3	7	15	33	44	48	54	54	54
65	6	10	21	40	57	86	102	102	102
80	7	16	37	56	84	182	246	246	246
100	9	22	51	88	134	187	255	336	336
125	21	33	91	153	232	331	468	560	560
150	45	69	149	281	302	597	822	1015	1072
200	55	131	254	420	631	904	1388	1758	1758
250	64	246	442	710	1056	1522	2128	3096	3096
300	100	275	472	953	1450	2093	2972	4193	4480
350	152	341	766	881	1773	2788	3978	6251	6260
400	182	542	1060	1764	2666	3836	5470	8403	8839
450	227	611	1229	2064	3133	4510	6458	9387	9387
500	342	837	1635	2795	4100	5896	8398	11830	13079
600	432	1143	2286	3833	6187	8369	11916	17917	17917

HEAD LOSS CALCULATIONS :

$$\Delta p = (Q / K_v)^2 \times SG$$

Q : flow in m³/h

Δp : Head loss in bar

SG : Specific gravity (= 1 for water)

Kv : Volume of water in m³/h, that will flow through a given restriction or valve opening with a pressure drop of 1 bar at 20°C)

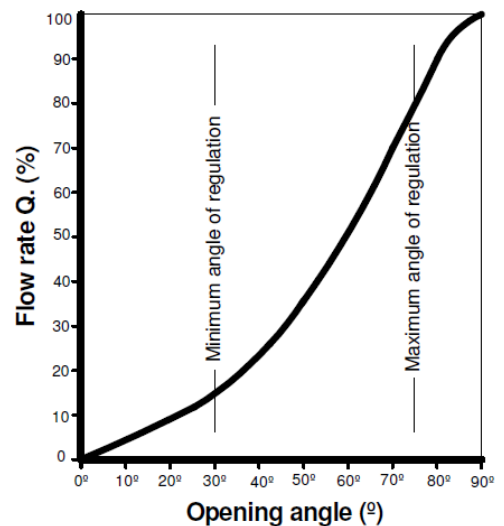

**WAFER BUTTERFLY VALVE EXCELLENCE RANGE
WITH FOOD SILICONE SEAT AND POLISH STAINLESS STEEL DISC**

PRESSURE / TEMPERATURE GRAPH (STEAM EXCLUDED):

- **DN40-300 :**

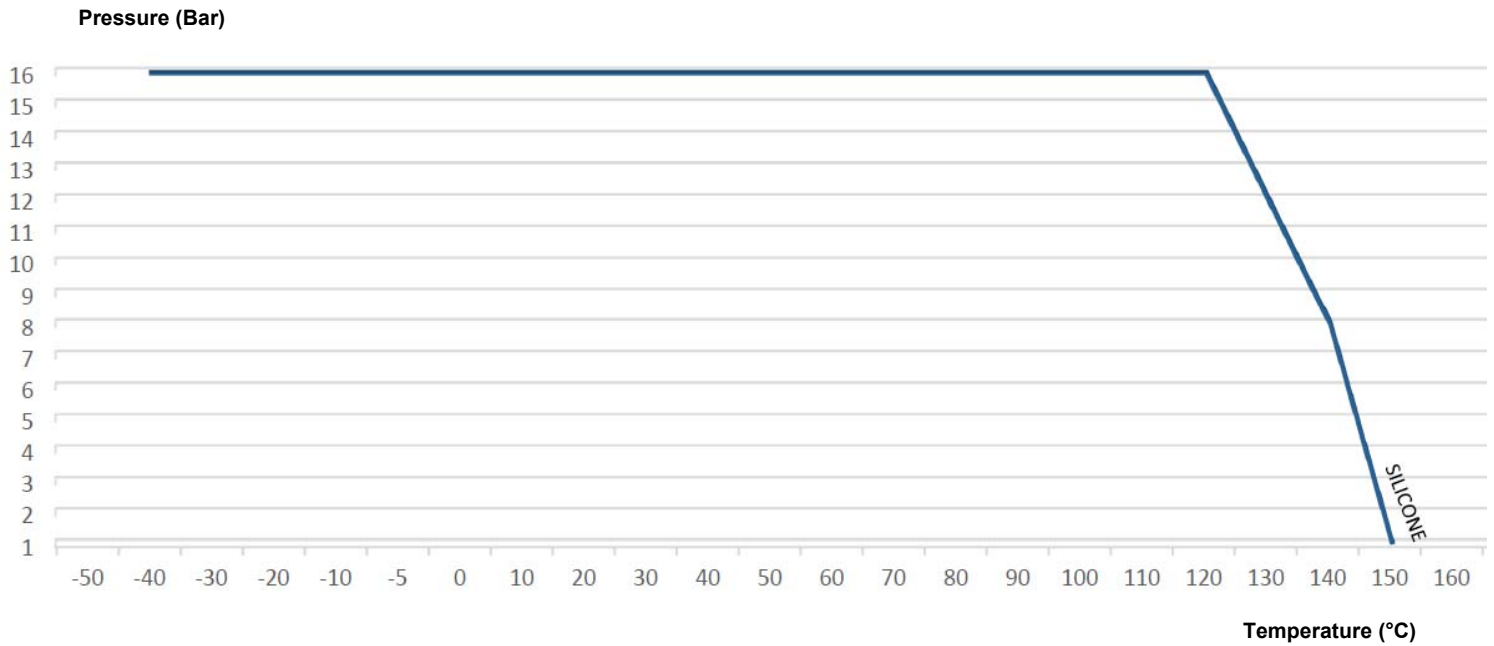

- **DN350-600 :**

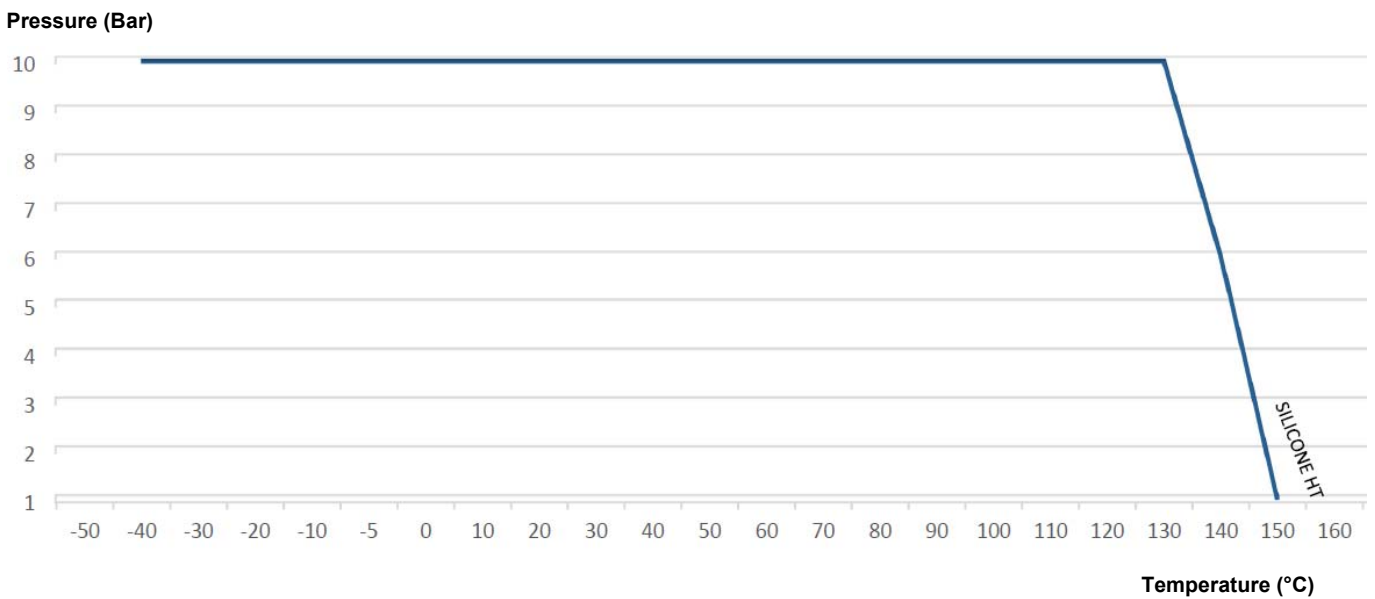

**WAFER BUTTERFLY VALVE EXCELLENCE RANGE
WITH FOOD SILICONE SEAT AND POLISH STAINLESS STEEL DISC**

MATERIALS DN 32 - 200 :

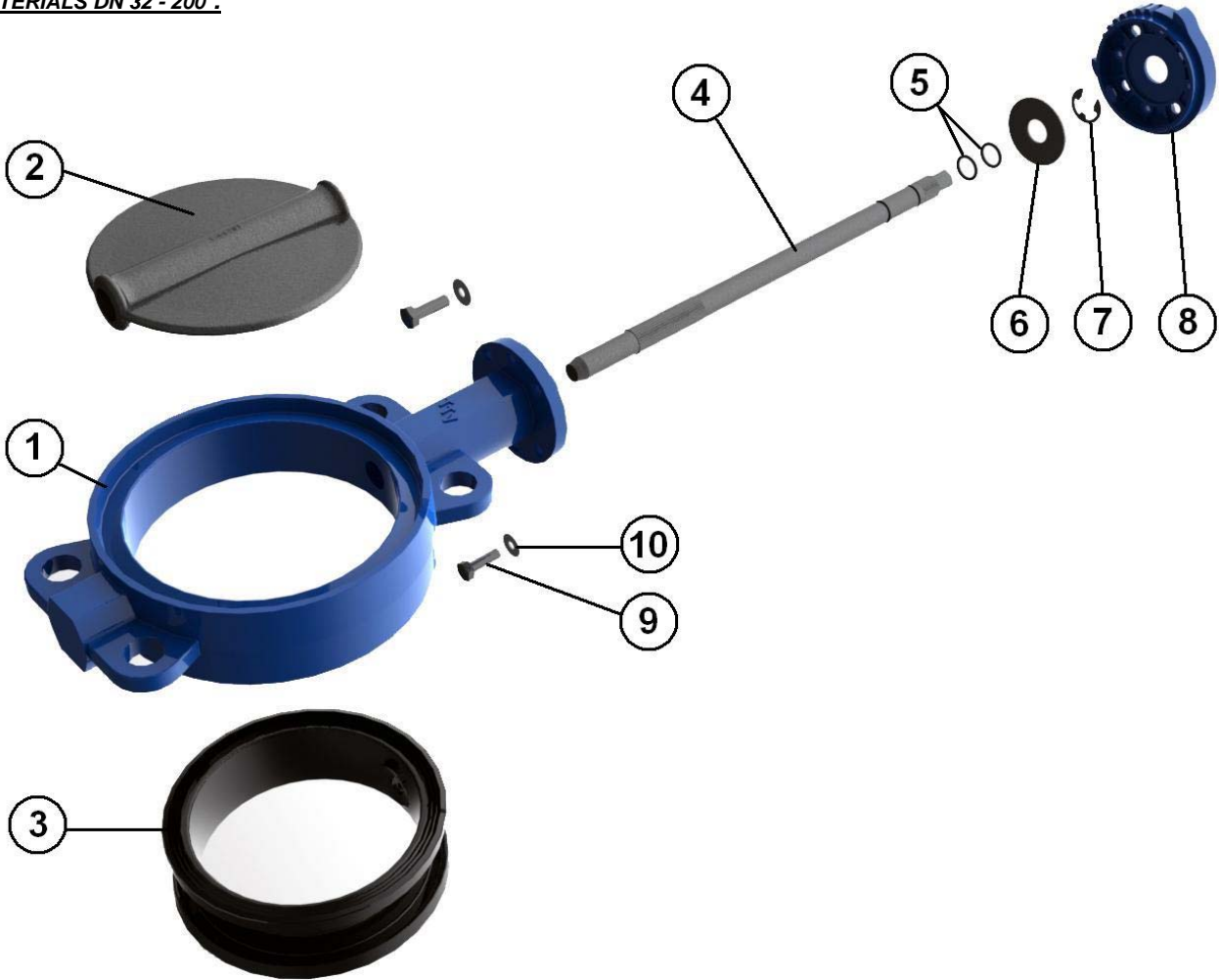

Item	Designation	Materials
1	Body	Ductile iron EN GJS-500-7 rilsan coated color RAL 5024 250-300 μ thickness
2	Disc	ASTM A351 CF8M polish
3	Seat	Food silicone
4	Stem	AISI 304
5	O ring	NBR
6	Ring	Steel
7	Circlips	Steel
8	Plate	Aluminium
9	Plate screw	5.6
10	Washer	Steel
	Handle	Aluminium ADC10 with epoxy painting 50μ thickness

**WAFER BUTTERFLY VALVE EXCELLENCE RANGE
WITH FOOD SILICONE SEAT AND POLISH STAINLESS STEEL DISC**

MATERIALS DN 250 - 400 :

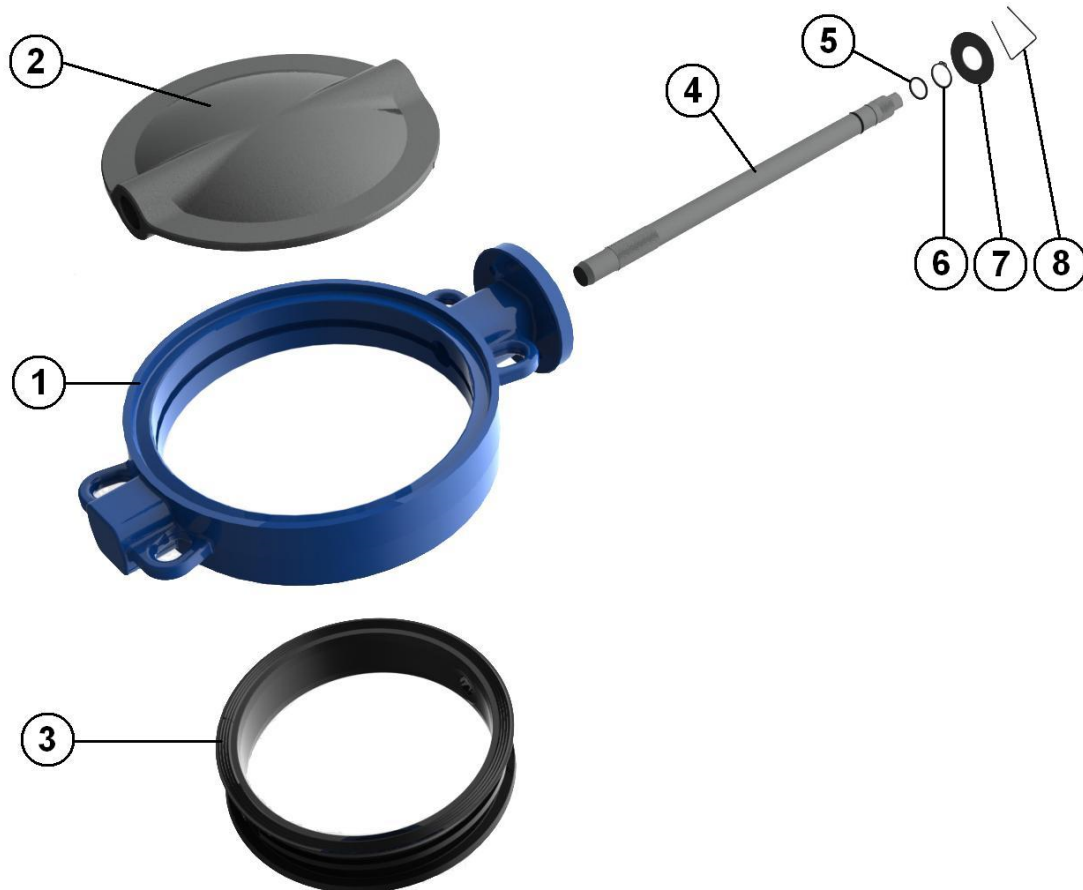

Item	Designation	Materials
1	Body	Ductile iron EN GJS-500-7 rilsan coated color RAL 5024 250-300 μ thickness
2	Disc	ASTM A351 CF8M polish
3	Seat	Food Silicone
4	Stem	AISI 304
5	O ring	NBR
6	Circlips	Steel
7	Ring	Steel
8	Spring	Steel
Handle (up to DN300)		Ductile iron EN GJS-500-7 with epoxy painting 50μ thickness

**WAFER BUTTERFLY VALVE EXCELLENCE RANGE
WITH FOOD SILICONE SEAT AND POLISH STAINLESS STEEL DISC**

MATERIALS DN 450 - 600 :

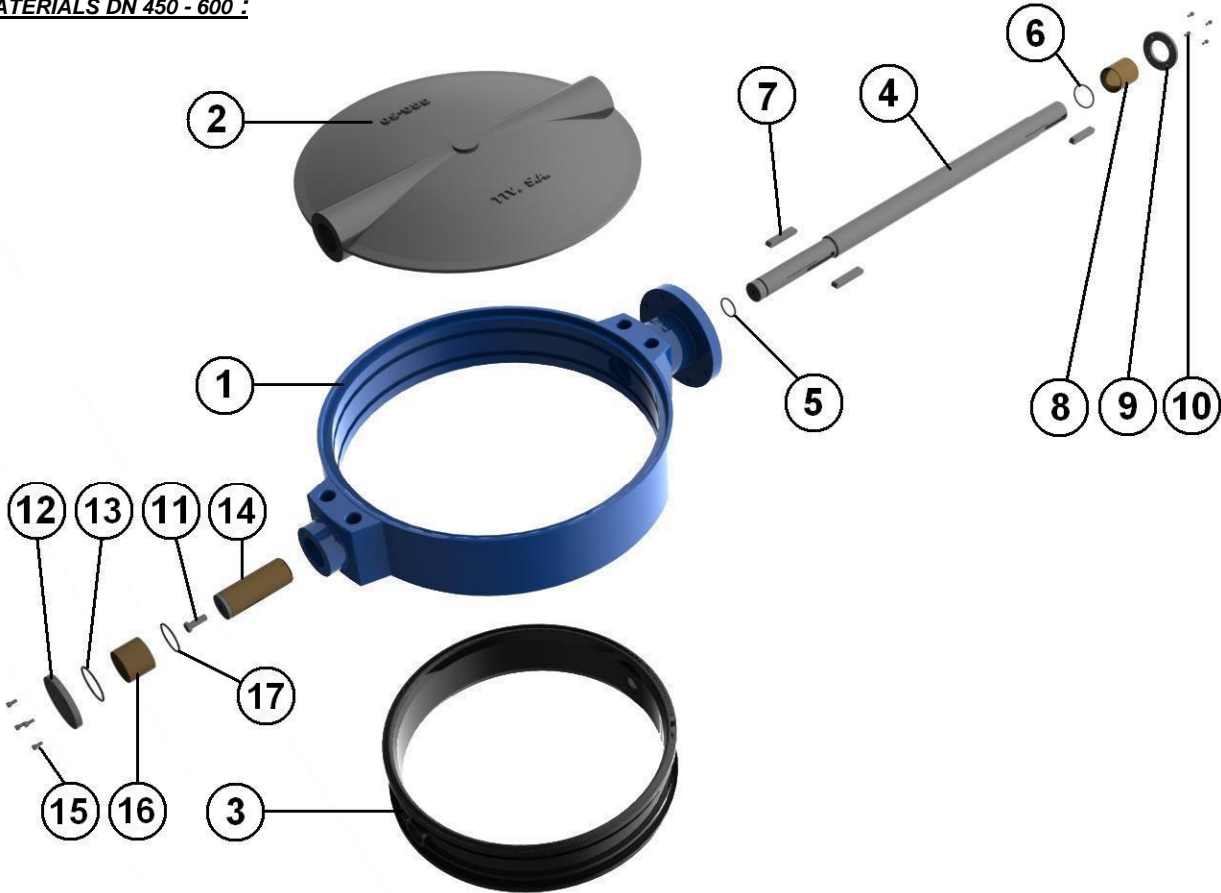

Item	Designation	Materials
1	Body	Ductile iron EN GJS-500-7 rilsan coated color RAL 5024 250-300 μ thickness
2	Disc	ASTM A351 CF8M polish
3	Seat	Food Silicone
4	Stem	AISI 304
5	O ring	NBR
6	O ring	NBR
7	Pin	ST – 60
8	Bushing	BRONZE
9	Ring	F1110
10	Screw	5.6
11	Screw	5.6
12	Cap	F1110
13	O ring	NBR
14	Bushing	F1110
15	Screw	5.6
16	Bushing	BRONZE
17	O ring	NBR

**WAFER BUTTERFLY VALVE EXCELLENCE RANGE
WITH FOOD SILICONE SEAT AND POLISH STAINLESS STEEL DISC**

GEARBOX MATERIALS REF. 1197 :

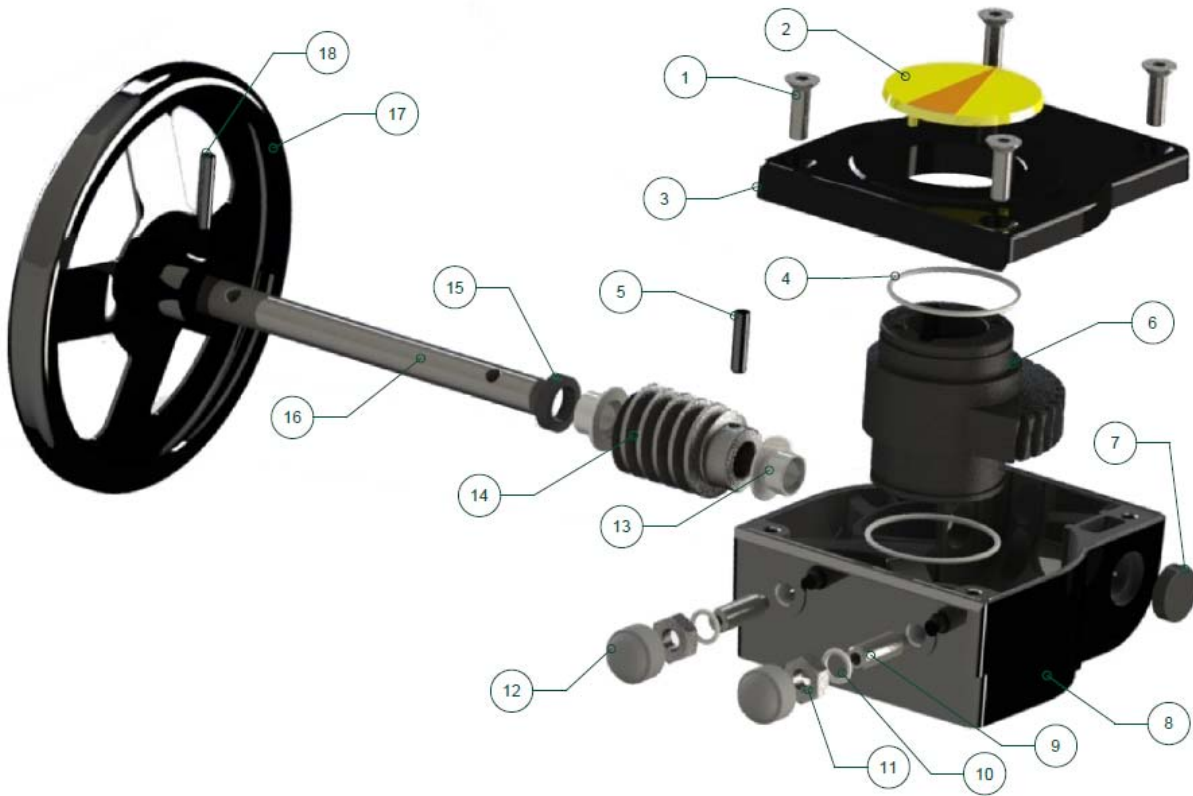

Item	Designation	Materials Ref. 1197
1	Screw	AISI 304
2	Pointer	Polypropylene
3	Bonnet	Aluminium
4	O ring	NBR
5	Pin	Carbon steel
6	Quadrant	Ductile iron EN GJS-400-15
7	Gasket	NBR
8	Body	Aluminium
9	Adjusting bolt	Carbon steel
10	Washer	Galvanized steel
11	Nut	Galvanized steel
12	Cap	NBR 70
13	Bushing	Bronze
14	Worm	Carbon steel 45
15	Gasket	NBR
16	Stem	Carbon steel 45
17	Handwheel	Carbon steel
18	Pin	Carbon steel

**WAFER BUTTERFLY VALVE EXCELLENCE RANGE
WITH FOOD SILICONE SEAT AND POLISH STAINLESS STEEL DISC**

SIZE (in mm) :

- Valves DN 32 - 200 :

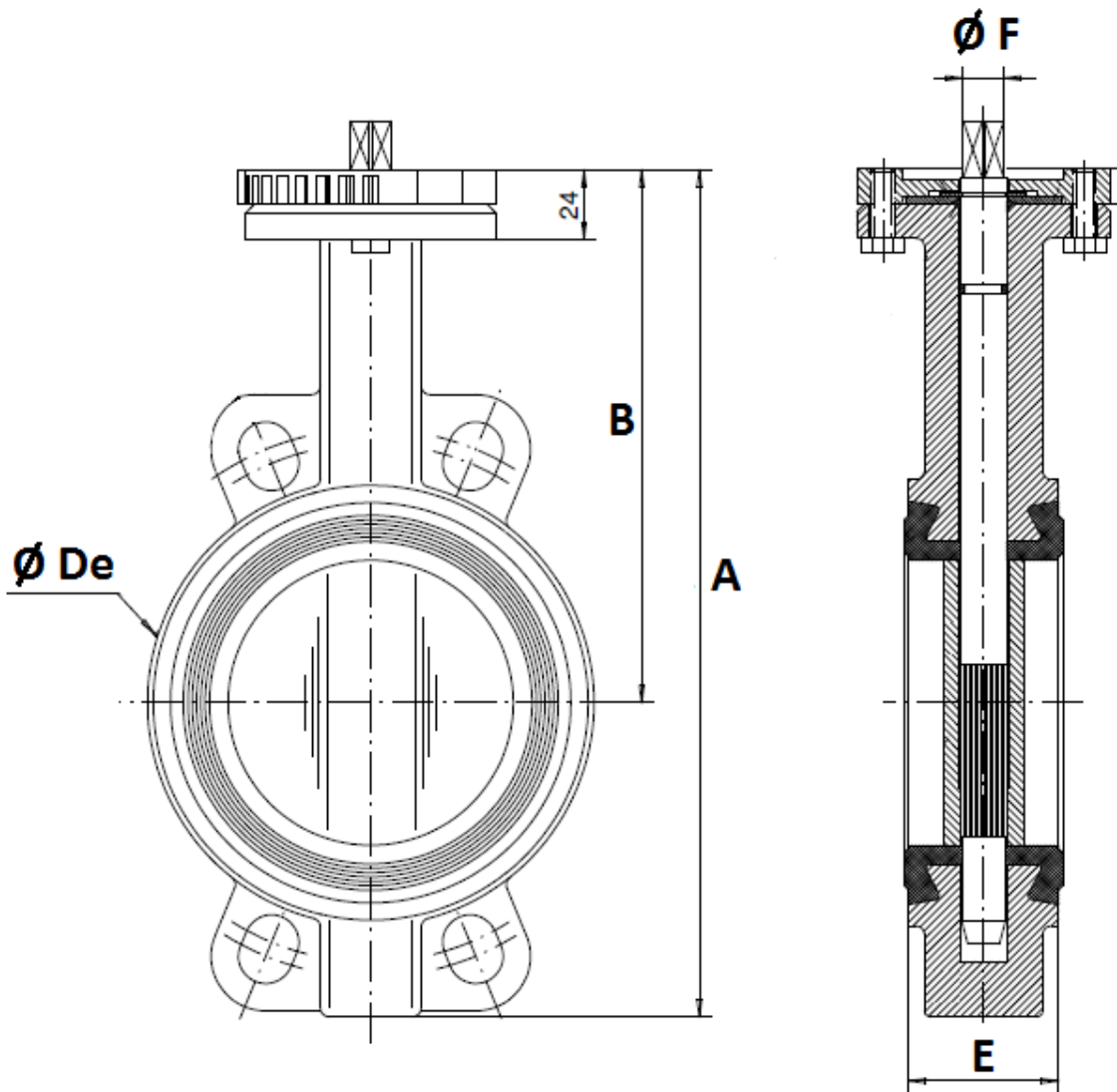

DN	32/40	50	65	80	100	125	150	200
A	206	228	248	265	298	331	349	430
B	140	156	161	169	187	206	215	255
Ø De	82	102	119	135	155	185	208	270
E	33	43	46	46	52	56	56	60
Ø F	9.5	9.5	12	14	14	17	17	21
Weight (Kg)	2.46	3.66	4.4	4.6	6	7.6	9.2	14.7

**WAFER BUTTERFLY VALVE EXCELLENCE RANGE
WITH FOOD SILICONE SEAT AND POLISH STAINLESS STEEL DISC**

SIZE (in mm) :

- Valves DN 250 -400 :

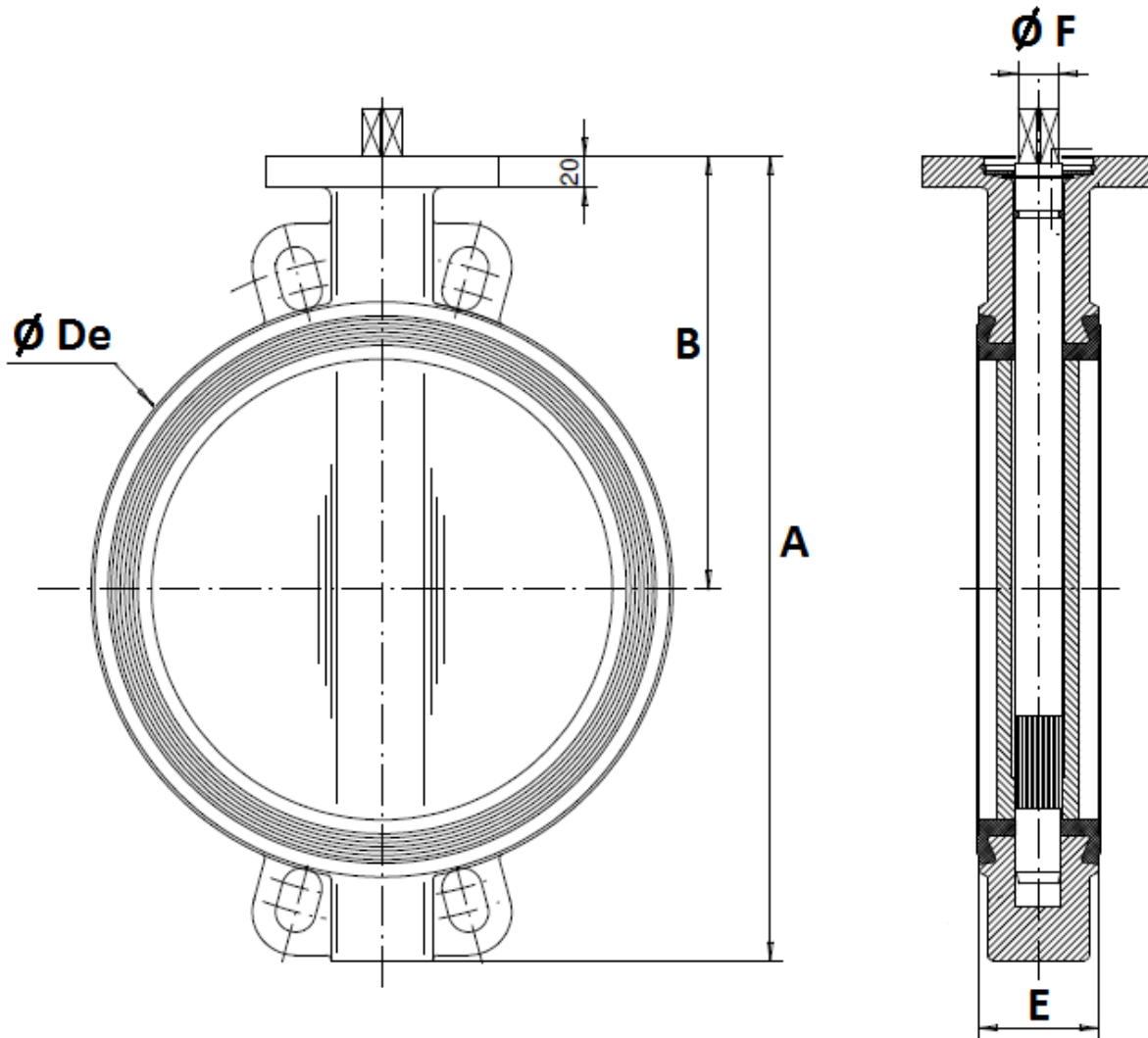

DN	250	300	350	400
A	461	524	570	644
B	248	280	300	340
Ø De	328	381	437	486
E	68	78	78	102
Ø F	23	26.5	26.5	33
Weight (Kg)	24.7	33	39	52

**WAFER BUTTERFLY VALVE EXCELLENCE RANGE
WITH FOOD SILICONE SEAT AND POLISH STAINLESS STEEL DISC**

STANDARD LEVERS SIZE (in mm) :

DN 32 – 200 :

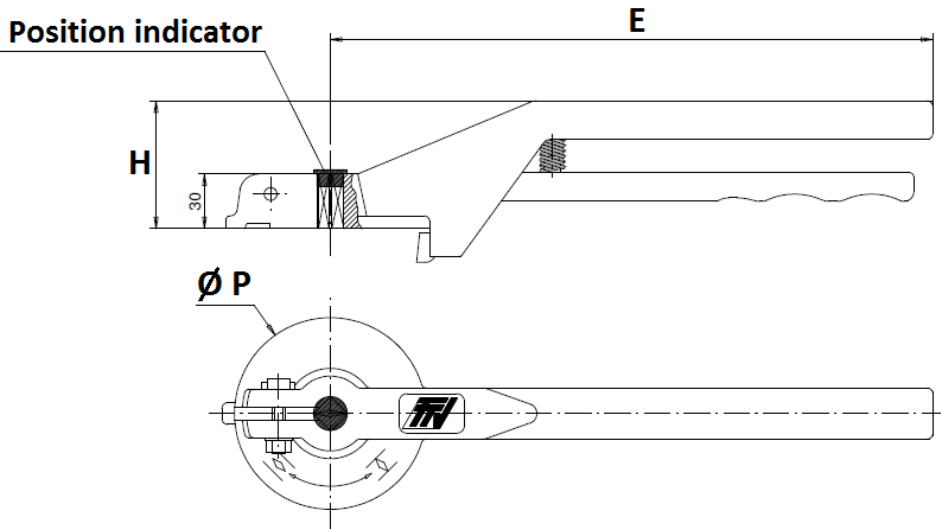

DN	32-100	125-200
E	205	330
H	57	70
Ø P	88	105

DN 250 – 300 :

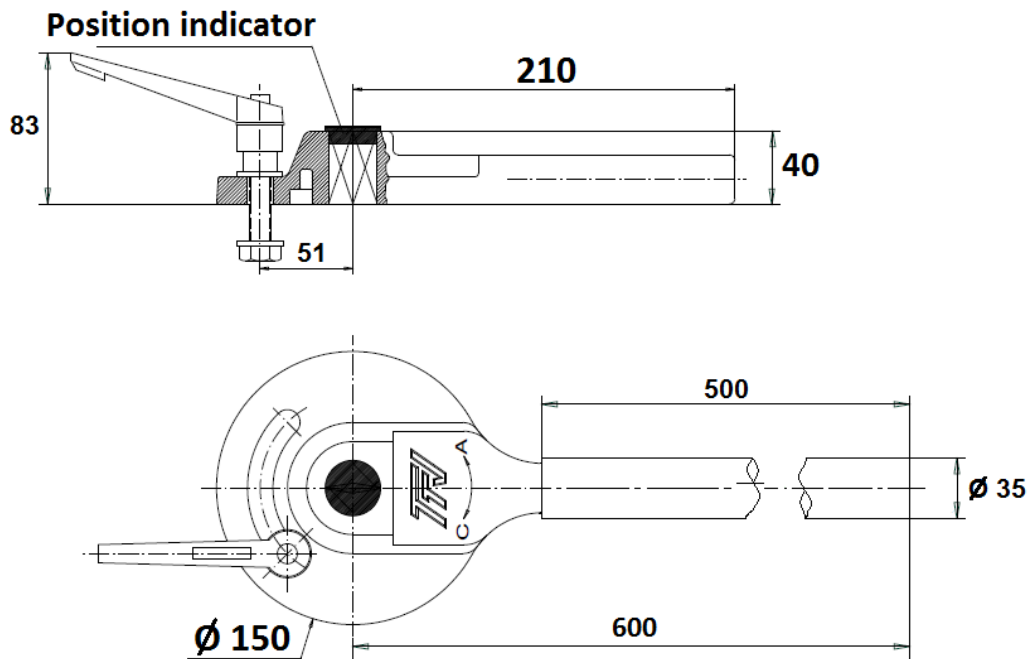

**WAFER BUTTERFLY VALVE EXCELLENCE RANGE
WITH FOOD SILICONE SEAT AND POLISH STAINLESS STEEL DISC**

ASTM A351 CF8M STAINLESS STEEL LEVERS SIZE (in mm) (ON REQUEST) :

DN 40 - 100

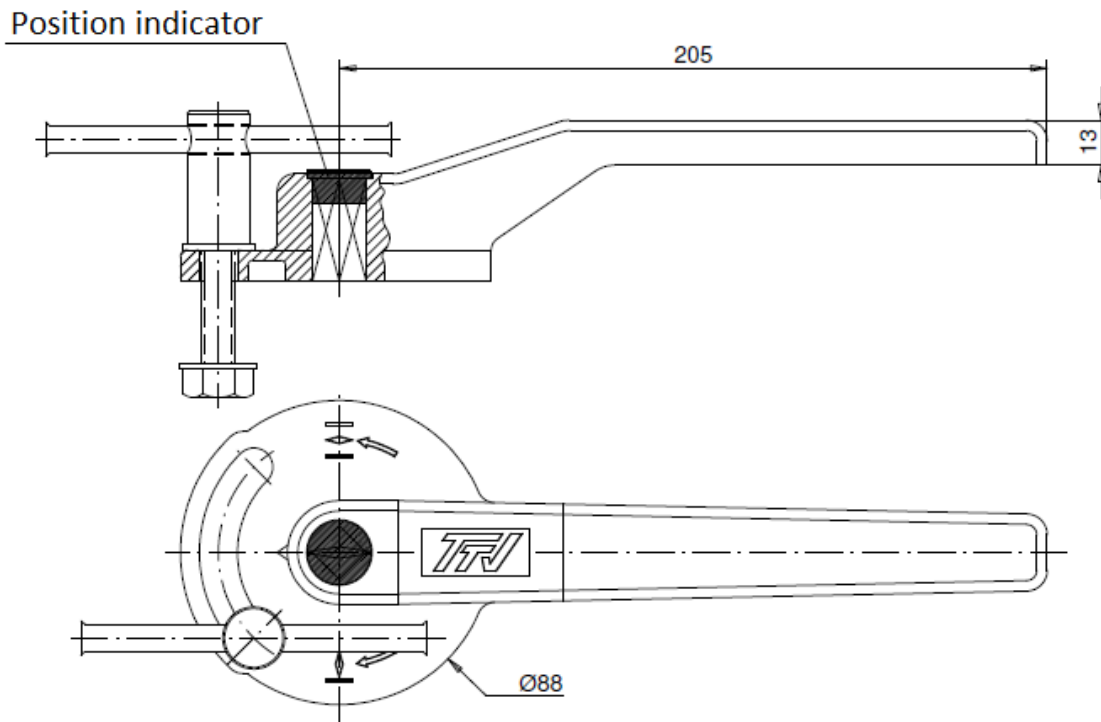

DN 125 - 200

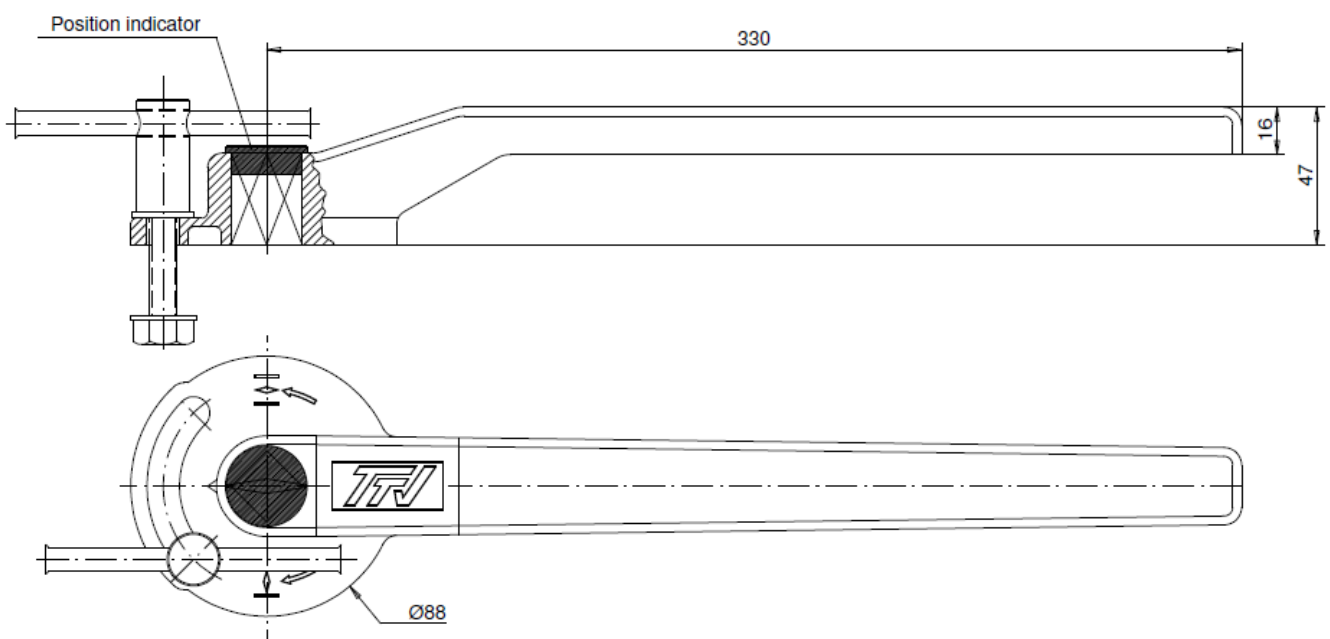

**WAFER BUTTERFLY VALVE EXCELLENCE RANGE
WITH FOOD SILICONE SEAT AND POLISH STAINLESS STEEL DISC**

SIZE (in mm) :

- Valves DN 450 - 600 :

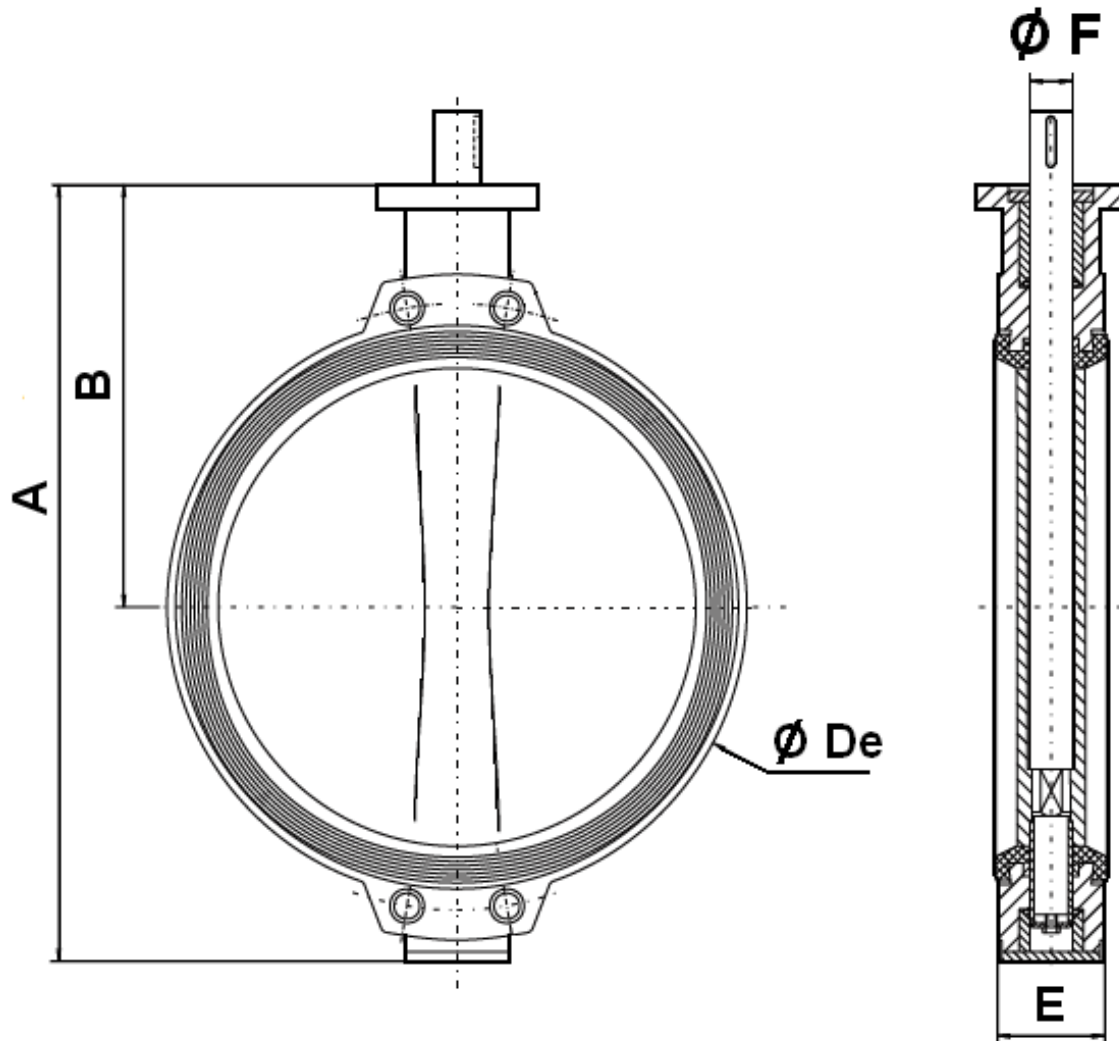

DN	450	500	600
A	738	822	965
B	394	440	507
Ø De	538	595	695
E	114	127	154
Ø F	50	50	60
Ø P	175	175	250
Weight (Kg)	87	117	177

**WAFER BUTTERFLY VALVE EXCELLENCE RANGE
WITH FOOD SILICONE SEAT AND POLISH STAINLESS STEEL DISC**

ISO MOUNTING PAD SIZE DN32-400 (in mm) :

DN 32 – 200

DN250-400

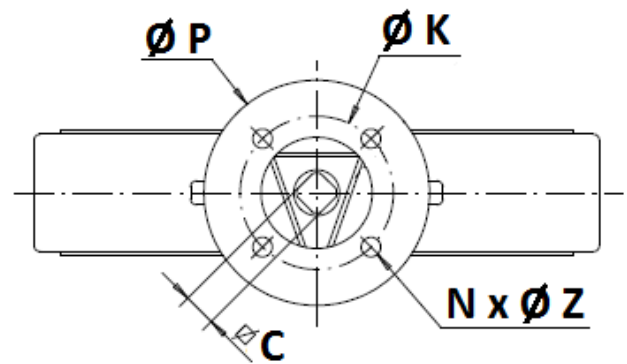
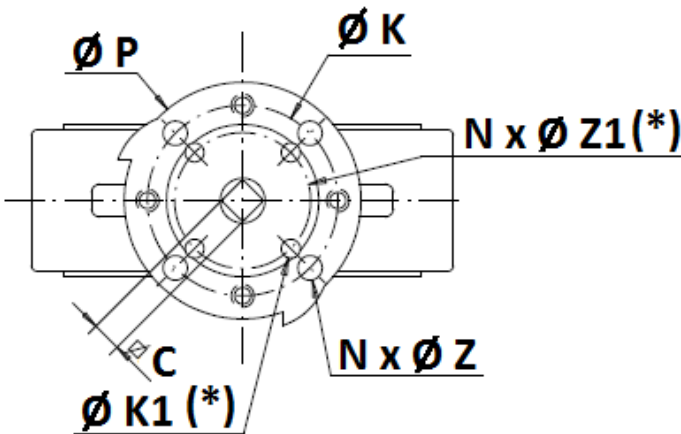
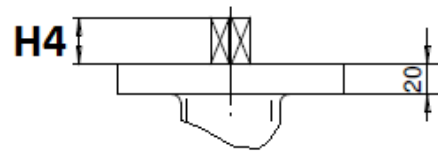
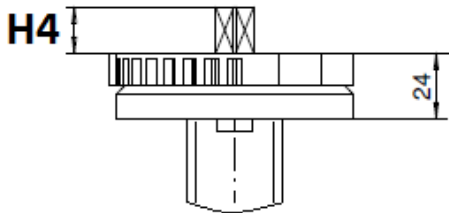

(*) : Only from DN32 to DN100

DN	32/40	50	65	80	100	125	150	200	250	300	350	400
H4	14	14	16	16	20	20	20	24	24	24	29	29
C	8	8	9	11	11	14	14	17	19	22	22	27
Ø K	70	70	70	70	70	70	70	70	102	102	140	140
ISO	F07	F07	F07	F07	F07	F07	F07	F07	F10	F10	F14	F14
N x Ø Z	4 x 9	4 x 9	4 x 9	4 x 9	4 x 9	4 x 9	4 x 9	4 x 9	4 x 11	4 x 11	4 x 18	4 x 18
Ø K1	50	50	50	50	50	-	-	-	-	-	-	-
ISO 1	F05	F05	F05	F05	F05	-	-	-	-	-	-	-
N x Ø Z1	4 x 7	4 x 7	4 x 7	4 x 7	4 x 7	-	-	-	-	-	-	-

**WAFER BUTTERFLY VALVE EXCELLENCE RANGE
WITH FOOD SILICONE SEAT AND POLISH STAINLESS STEEL DISC**

ISO MOUNTING PAD SIZE DN450-600 (in mm) :

DN 450 - 600

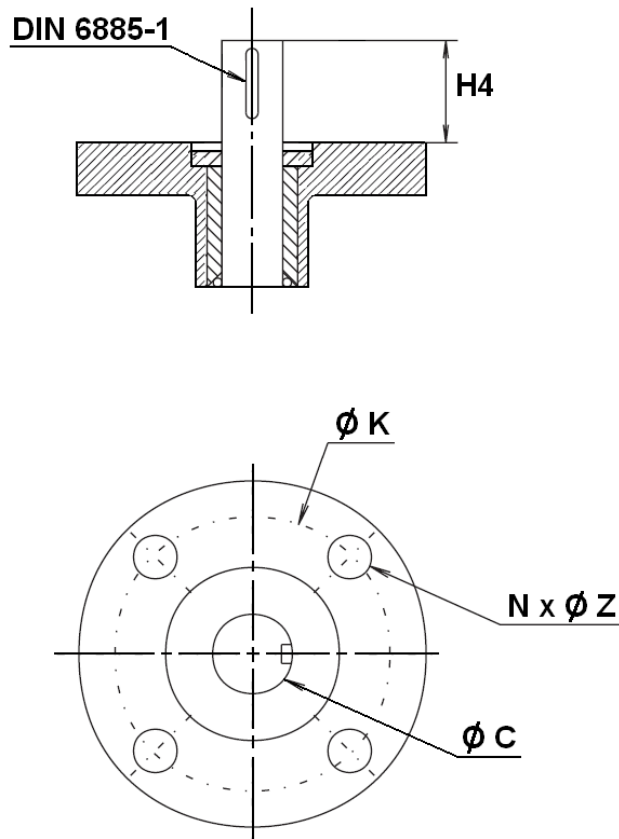

DN	450	500	600
H4	80	80	90
Ø C	50	50	60
Ø K	140	140	165
ISO	F14	F14	F16
N x Ø Z	4 x 18	4 x 18	4 x 22

**WAFER BUTTERFLY VALVE EXCELLENCE RANGE
WITH FOOD SILICONE SEAT AND POLISH STAINLESS STEEL DISC**

SIZE (in mm) :

- Valves with gearbox DN 32 - 400 :

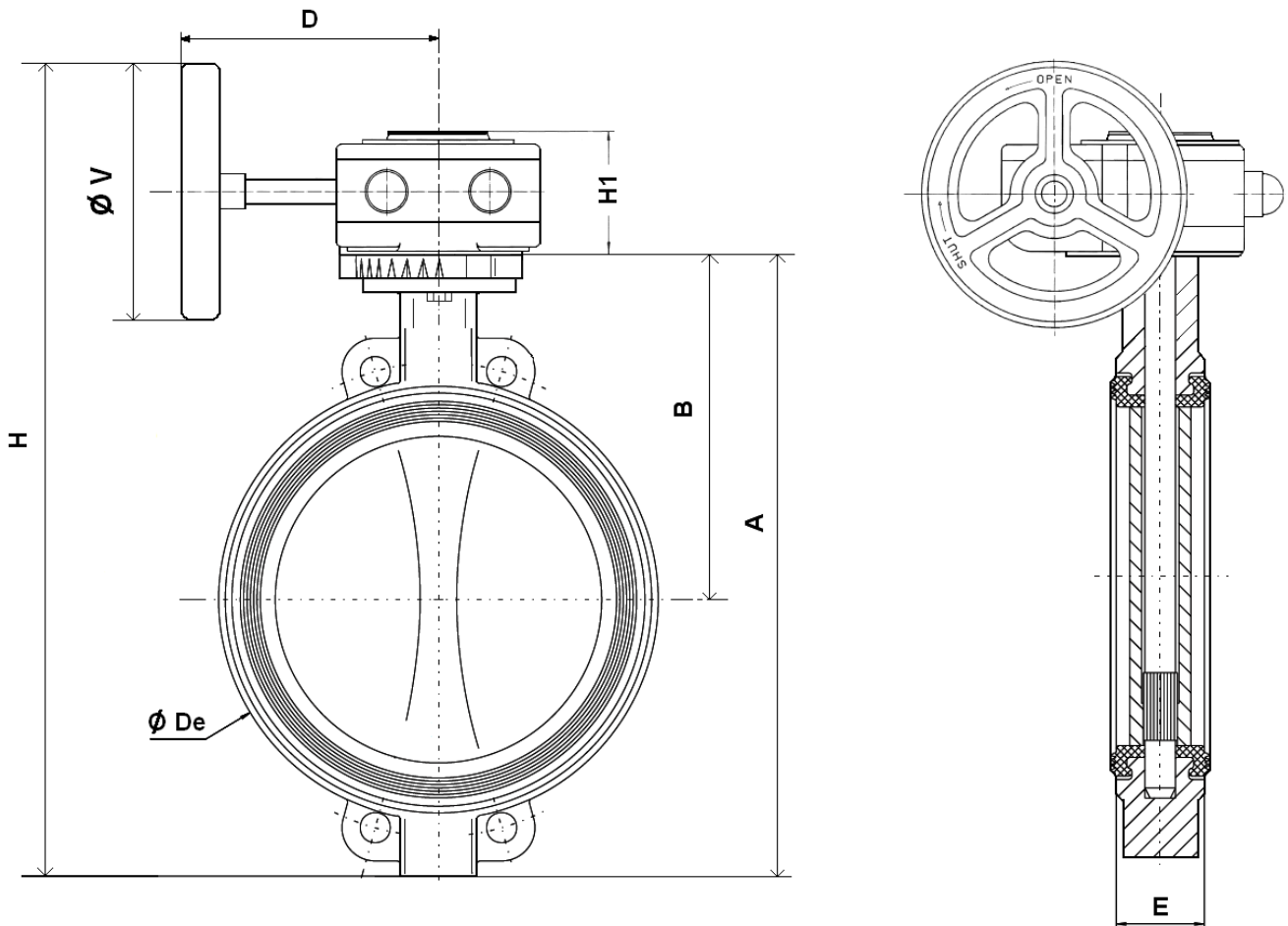

DN	32/40	50	65	80	100	125	150	200	250	300	350	400
A	206	228	248	265	298	331	349	430	461	524	570	644
B	140	156	161	169	187	206	215	255	248	280	300	340
ϕDe	82	102	119	135	155	185	208	270	328	381	437	486
D	120	120	120	120	120	136	136	136	223	223	345	345
E	33	43	46	46	52	56	56	60	68	78	78	102
H	304	326	341	364	392	452	477	566	647	709	831	894
H1	58	58	58	58	58	58	58	58	74	74	98	98
ϕV	140	140	140	140	140	200	200	200	300	300	400	400
Weight (Kg)	3.81	5.01	5.75	5.95	7.35	9.35	10.95	16.45	28.7	37	48.5	61.5

**WAFER BUTTERFLY VALVE EXCELLENCE RANGE
WITH FOOD SILICONE SEAT AND POLISH STAINLESS STEEL DISC**

SIZE (in mm) :

- Valves with gearbox DN 450 - 600 :

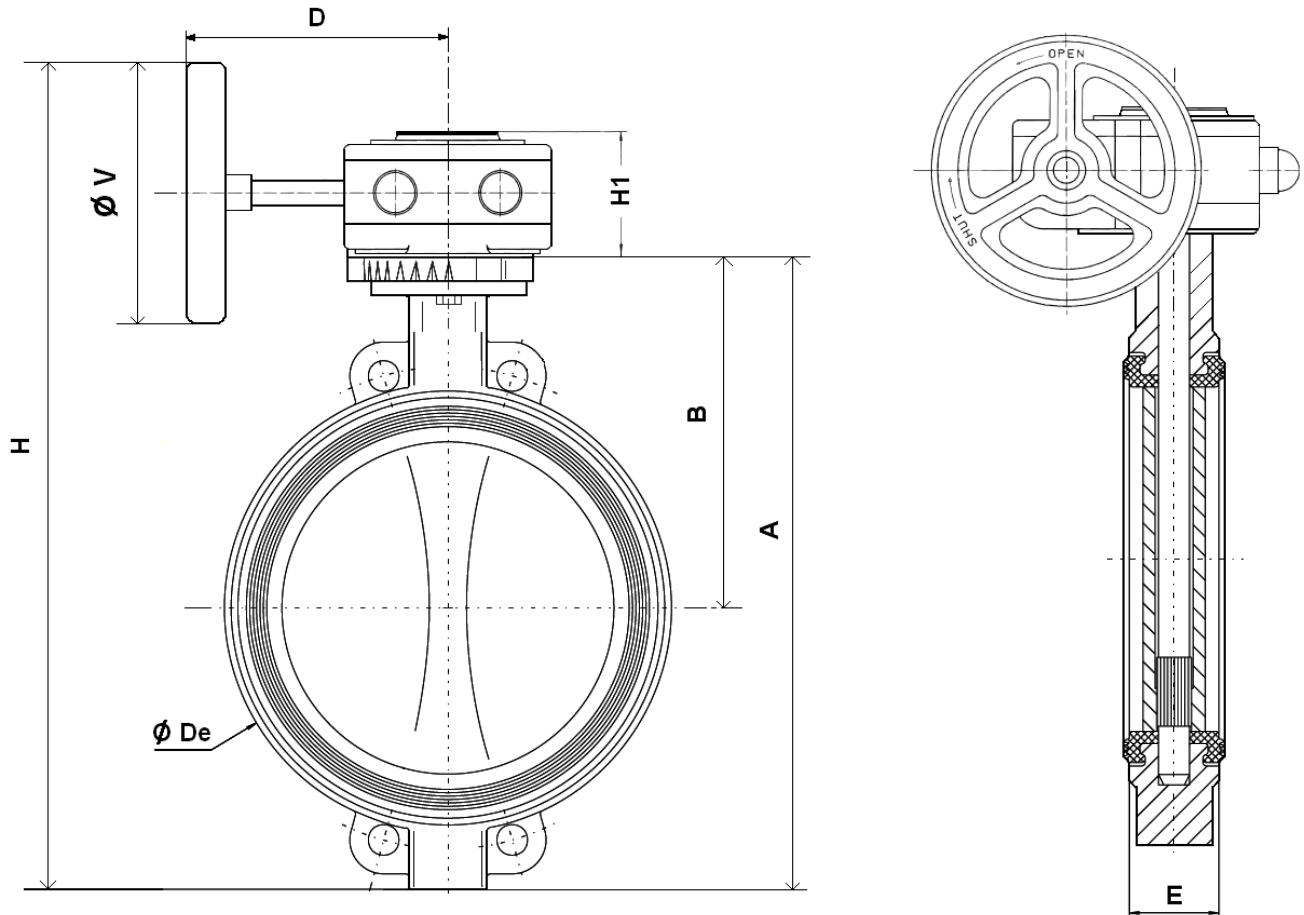

DN	450	500	600
A	738	822	965
B	394	440	507
ϕDe	538	595	695
D	364	386	421
E	114	127	154
H	1083	1171	1376
H1	90	98	122
ϕV	600	600	700
Weight (Kg)	105.8	143.8	215.3

**WAFER BUTTERFLY VALVE EXCELLENCE RANGE
WITH FOOD SILICONE SEAT AND POLISH STAINLESS STEEL DISC**

SIZE (in mm) :

- Valves with chain gear box :

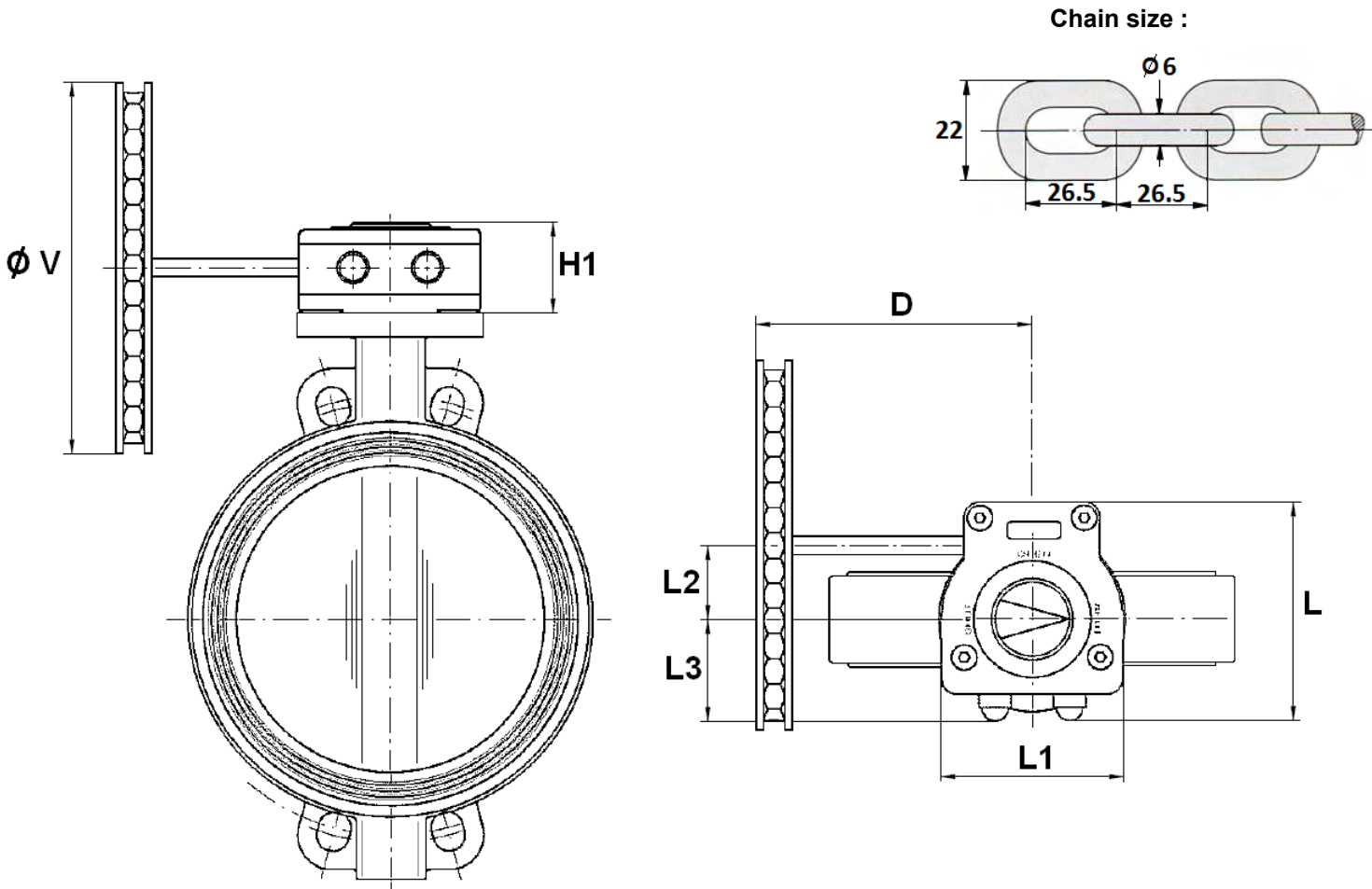

DN	32/40	50	65	80	100	125	150	200	250	300	350	400	450	500
D	120	120	120	120	120	126	126	126	214	214	331	331	350	365
H1	58	58	58	58	58	58	58	58	74	74	98	98	90	98
L	128	128	128	128	128	128	128	128	175	175	224	224	232	267
L1	100	100	100	100	100	100	100	100	142	142	185	185	204	227
L2	50	50	50	50	50	50	50	50	61	61	80	80	86	104.5
L3	56	56	56	56	56	56	56	56	80	80	98	98	100	110
Ø V	160	160	160	160	160	210	210	210	300	300	400	400	500	500
Weight (Kg)	4.81	6.01	6.75	6.95	8.35	10.35	11.95	17.45	31.5	39.8	53.3	66.3	113.2	150.7

**WAFER BUTTERFLY VALVE EXCELLENCE RANGE
 WITH FOOD SILICONE SEAT AND POLISH STAINLESS STEEL DISC**

GEARBOX SPECIFICATIONS :

DN	32/50	65	80/100	125/150	200	250	300	350
Ref.	1197050	1197065	1197100	1197150	1197200	1197250	1197300	1197350
Ratio factor	37 : 1	37 : 1	37 : 1	37 : 1	37 : 1	36 : 1	36 : 1	50 : 1
Turns number for closing / opening	9.25	9.25	9.25	9.25	9.25	9	9	12.5
Input torque (Nm)	12.5	12.5	12.5	12.5	12.5	23	23	50
Output torque (Nm)	300	300	300	300	300	675	675	1310

DN	400	450	500	600
Ref.	1197400	1197451	1197501	1197601
Ratio factor	50 : 1	38 : 1	55 : 1	52 : 1
Turns number for closing / opening	12.5	9.5	13.75	13
Input torque (Nm)	50	86	96	160
Output torque (Nm)	1310	1620	2640	4160

**WAFER BUTTERFLY VALVE EXCELLENCE RANGE
WITH FOOD SILICONE SEAT AND POLISH STAINLESS STEEL DISC**

BETWEEN FLANGES SIZE (in mm) :

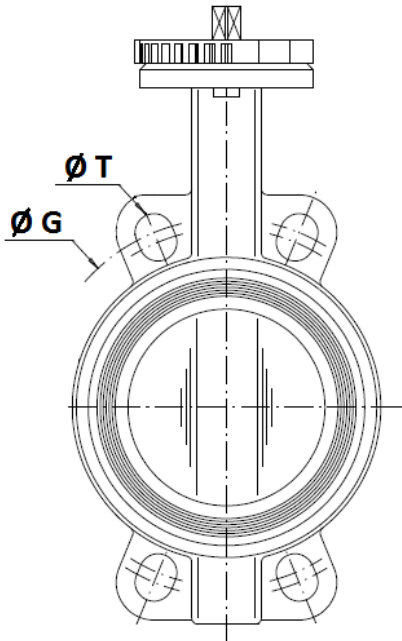
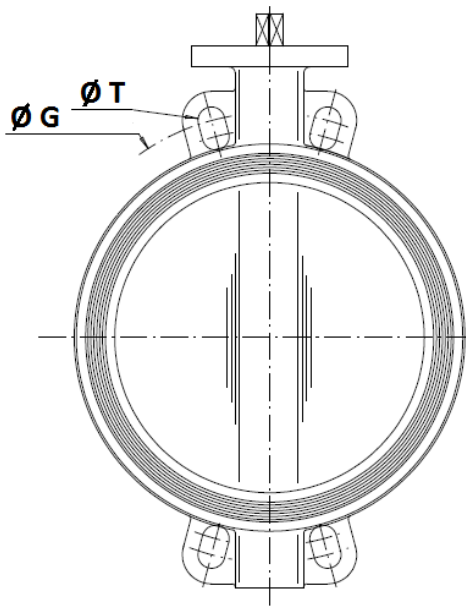
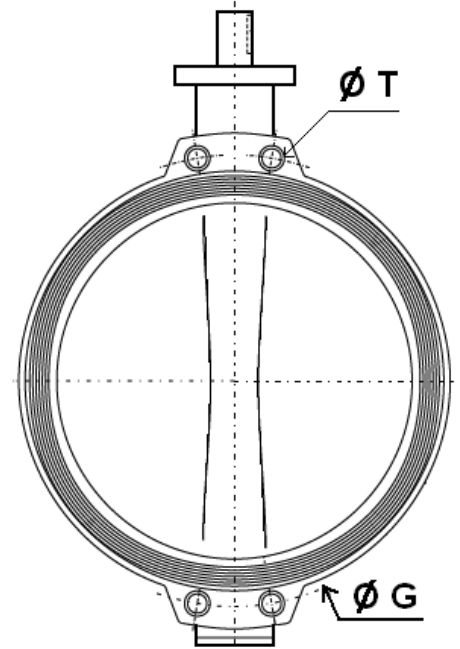
DN 32-200

DN250 – 400

DN450-600

	DN (mm)	32	40	50	65	80	100	125	150	200	250	300	350	400
	NPS (")	1"1/4	1"1/2	2"	2"1/2	3"	4"	5"	6"	8"	10"	12"	14"	16"
PN10	Ø G	100	110	125	145	160	180	210	240	295	350	400	460	515
	Ø T	18	18	18	18	18	18	18	23	23	23	23	23	27
PN16	Ø G	100	110	125	145	160	180	210	240	295	355	410	470	525
	Ø T	18	18	18	18	18	18	18	23	23	27	27	27	30
Class 150	Ø G	88.9	98.5	120.6	139.7	152.4	190.5	215.9	241.3	298.5	362	431.8	476.3	539.8
	Ø T	16	16	19	19	19	19	23	23	23	26	26	29	29

	DN (mm)	450	500	600
	NPS (")	18"	20"	24"
PN10	Ø G	565	620	725
	Ø T	M24	M24	M27
PN16	Ø G	585	650	770
	Ø T	M27	M30	M33
Class 150	Ø G	577.9	635	749.3
	Ø T (BSW)*	1 1/8"	1 1/8"	1 1/4"
	Ø T (Metric)	M30	M30	M33

* Threaded BSW on standard, on request metric threaded for Class 150

**WAFER BUTTERFLY VALVE EXCELLENCE RANGE
WITH FOOD SILICONE SEAT AND POLISH STAINLESS STEEL DISC**

NECK AND DISC SIZE (in mm) :

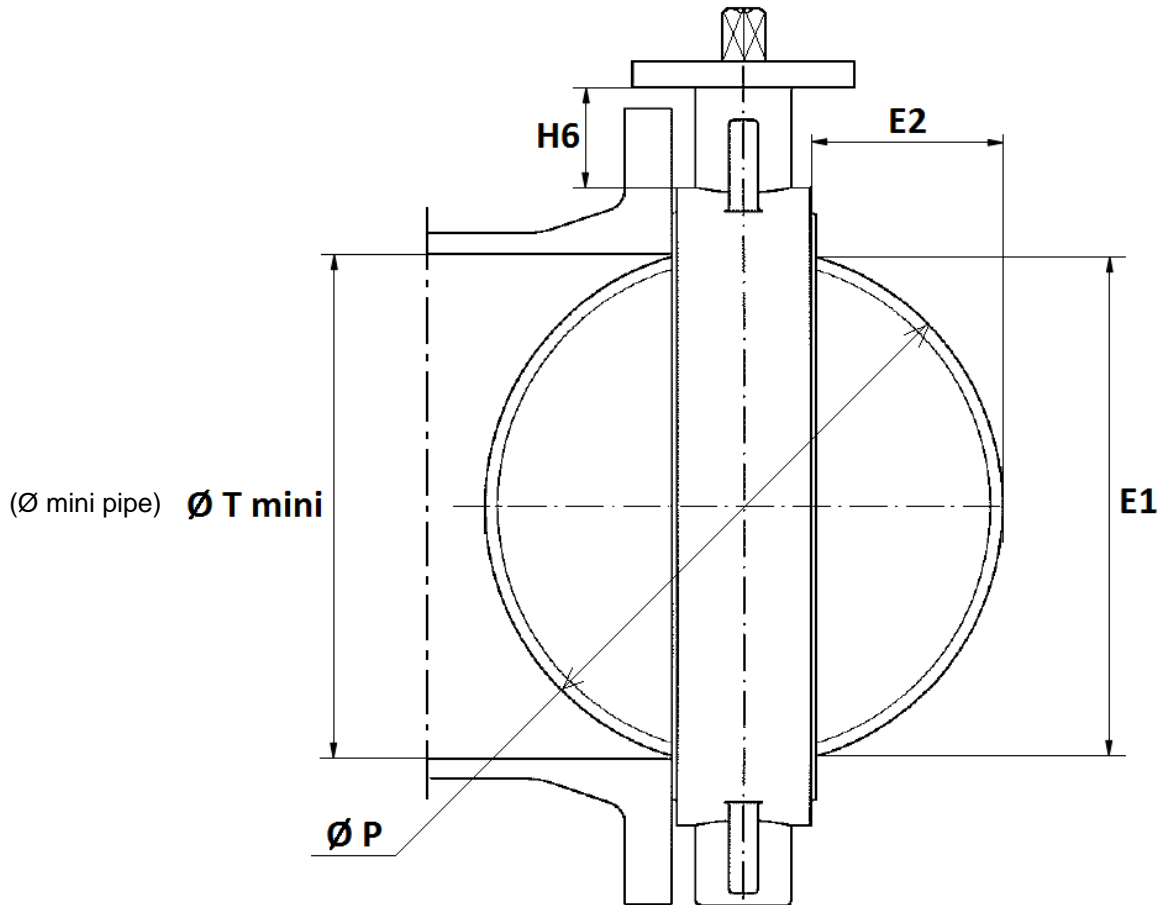

DN	32/40	50	65	80	100	125	150	200	250	300	350	400	450	500	600
E1	23	24.5	46	65	85	109	136	188	238	289	331	385	424	479	575
E2	3.5	3.5	9.5	17	24	33.5	45.5	69	90	110.5	131	148	162.5	184	221
H6	76	82	80	80	88	93	89	99	71	76	69	80	96	119	127
Ø T mini	26	27.5	49	68	88	112	139	191	241	292	334	388	427	482	578
Ø P	40	50	65	80	100	123	147	198	248	299	340	398	439	495	596

**WAFER BUTTERFLY VALVE EXCELLENCE RANGE
WITH FOOD SILICONE SEAT AND POLISH STAINLESS STEEL DISC**

SIZE (in mm) :

- **Square lever for special key (30x30 mm) :**

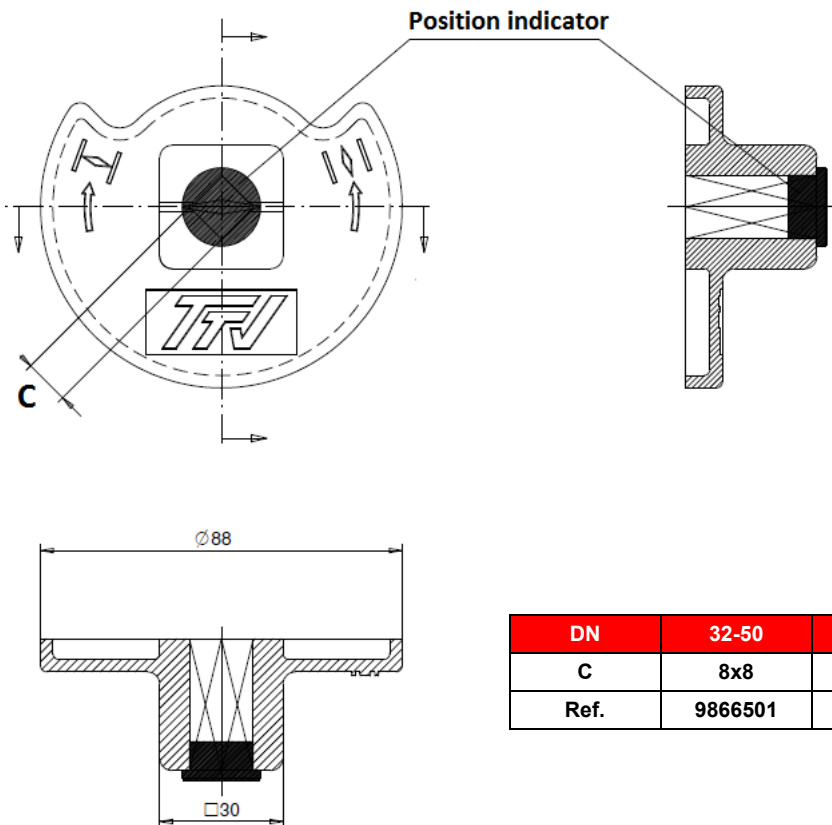

DN	32-50	65	80-100	125-150	200
C	8x8	9x9	11x11	14x14	17x17
Ref.	9866501	9866502	9866503	9866504	9866505

**WAFER BUTTERFLY VALVE EXCELLENCE RANGE
WITH FOOD SILICONE SEAT AND POLISH STAINLESS STEEL DISC**

STANDARDS :

- Fabrication according to ISO 9001:2015
- Designing according to ISO 10631 and EN 593
- DIRECTIVE 2014/68/EU : CE N° 0038
Risk Category III module H
- Certificate 3.1 on request
- Tests according to EN 12266-1, Rate A
- Between flanges according to EN 1092-1 PN10/16
- ISO 5211 mounting pad
- Length according to ISO 5752 short series 20, EN 558 series 20 (NF 29305),BS 5155 Wafer short/medium, DIN 3202 part 3, series K1
- ATEX Group II Category 2 G/2D Zone 1 & 21 Zone 2 & 22 (optional marking)
- Approval certificate **Marine BUREAU VERITAS**, N° 14087/B0 BV
- OTAN agreement (N° 286B)
- Food silicone elastic ring produced according to requirements **FDA**

ADVICE : Our opinion and our advice are not guaranteed and SFERACO shall not be liable for the consequences of damages.
The customer must check the right choice of the products with the real service conditions.

**WAFER BUTTERFLY VALVE EXCELLENCE RANGE
 WITH FOOD SILICONE SEAT AND POLISH STAINLESS STEEL DISC**

INSTALLATION INSTRUCTIONS

GENERAL GUIDELINES :

- Ensure that the valves to be used are appropriate for the conditions of the installation (type of fluid, pressure and temperature).
- Be sure to have enough valves to be able to isolate the sections of piping as well as the appropriate equipment for maintenance and repair.
- Ensure that the valves to be installed are of correct strength to be able to support the capacity of their usage.
- **Installation of all circuits should ensure that their function can be automatically tested on a regular basis (at least two times a year).**

INSTALLATION INSTRUCTIONS :

- **Before installing the valves, clean and remove any objects from the pipes** (in particular bits of sealing and metal) which could obstruct and block the valves.
- **Ensure that both connecting pipes either side of the valve (upstream and downstream) are aligned (if they're not, the valves may not work correctly).**
- **Make sure that the two sections of the pipe (upstream and downstream) match, the valve unit will not absorb any gaps. Any distortions in the pipes may affect the tightness of the connection, the working of the valve and can even cause a rupture.** To be sure, place the kit in position to ensure the assembling will work.
- **If sections of piping do not have their final support in place, they should be temporarily fixed. This is to avoid unnecessary strain on the valve.**
- The valve must be inserted between flanges with disc half opened but the disc must not overpass the valve thickness. Position the bolts to keep centered the valve. Then open fully the valve and tighten the bolts.
See graph under.

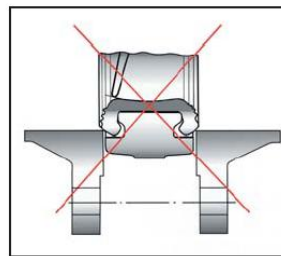
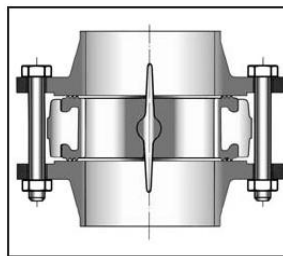
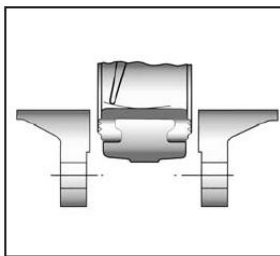

**Half open valve introduction Complete opened disc valves
 when screw tightening**

- Tighten the bolts in cross.
- The disc must move easily inside the pipe.
- Valves must be opened during cleaning operation.
- Tests must be done with a cleaned pipe.
- Tests must be done with opened valve. Test pressure must not be higher than the valve specification according to EN 12266-1.
- Then open slowly the valve.
- **Do not mount butterfly valves with stainless steel pressed collars and turning flanges without strias.**
- **And not on flat face flanges without strias (example : painted cast iron fittings)**

**WAFER BUTTERFLY VALVE EXCELLENCE RANGE
 WITH FOOD SILICONE SEAT AND POLISH STAINLESS STEEL DISC**

MAXIMUM TIGHTENING TORQUES FOR BOLTING FLANGES :

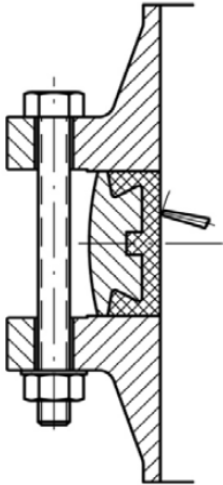

		Maximum torques (Nm)			
		Bolting types	5,6 / A307 Gr.B	8,8 / A193 B7	10,9
Bolting DN	M12 (1/2")	41,16	84,28	117,6	142,1
	M14 (9/16")	66,64	132,3	186,2	225,4
	M16 (5/8")	102,9	205,8	289,1	347,9
	M18 (3/4")	142,1	284,2	396,9	475,3
	M20 (3/4")	196	401,8	568,4	676,2
	M22 (7/8")	259,7	539	764,4	911,4
	M24 (1")	338,1	695,8	980	1176
	M27 (1"1/8)	499,8	1029	1470	1764
	M30 (1"1/4)	666,4	1421	1960	2352

BEST POSITION INSTALLATION :

For wastewater, fluids with solid particles or cold network (air conditioning for example), the best position is the horizontal one :



MAINTENANCE :

- We recommend to operate fully the valve 1 to 2 times per year.
- During maintenance operation, ensure that the pipe isn't under pressure, that there's no fluid in the pipe and that the valve is isolated. If there's a fluid in the pipe , evacuate it. Ensure that there are no risks due to the temperature or the fluid (like acids). If the fluid is corrosive , inert the installation before maintenance operation.