

TRIPLE OFFSET LUG BUTTERFLY VALVE PN40



Management
System
ISO 9001 : 2015



Certificate 3.1



FIRE SAFE
ISO 10497



Size : DN 100 to 300 mm
Ends : Between PN40 flanges
Min Temperature : - 39°C
Max Temperature : + 349°C
Max Pressure : 40 Bars
Specifications : Triple offset
Lug type
Fire safe according to ISO 10497 : 2010
ISO 5211 mounting pad

Materials : Carbon steel A216 WCB

TRIPLE OFFSET LUG BUTTERFLY VALVE PN40

SPECIFICATIONS :

- 100% tightness
- Lug type
- Between PN40 flanges
- Triple offset
- Bidirectional with preferential flow direction indicated by the arrow (30 bars maximum if the flow is not according to the arrow)
- Fire safe according to ISO 10497 : 2010
- ISO 5211 mounting pad
- Stainless steel CF8M disc
- Full crossing stem
- **Bare shaft (possible with gear box Ref.1191)**
- Inorganic zinc rich primer, gray color, 10 µm thickness
- Finish painting heat resisting aluminum Silver color RAL 9006, 30 µm thickness

USE :

- Heating, geothermics, industrial cold, shipbuilding, petrochemical
- Steam : 30 bars maximum
- Min and max Temperature Ts : - 39°C to + 349°C
- Max Pressure Ps : 40 bars (see graph), 30 bars if valve installed in reverse flow direction indicated by the arrow
- When using at dead end of pipeline, reverse preferential flow direction
- Max pressure at dead end of pipeline is 30 bars

RANGE :

- Triple offset Lug butterfly valve type PN40 **bare shaft Ref. 1118** DN 100 to DN 300
- Gear box **Ref. 1191** from DN 100 to DN 300

ENDS :

- Between PN40 flanges

PRESSURE / TEMPERATURE GRAPH :

PRESSURE (Bar)

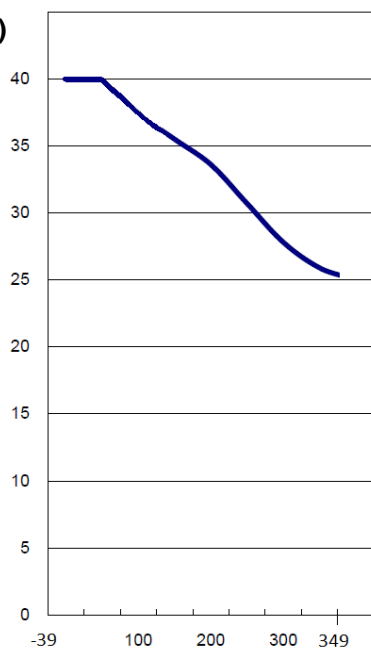

TEMPERATURE (°C)

Relation Pressure / Temperature	
Temperature (°C)	Pressure (Bar)
0	40
50	40
100	37.4
150	35.5
200	33.6
250	30.7
300	27.8
349	25.9

TRIPLE OFFSET LUG BUTTERFLY VALVE PN40

TORQUE VALUE (in Nm with safety coefficient of 30 % included) :

DN	100	150	200	250	300
Torque (Nm) at 12.5 Bar	226	429	504	930	1317
Torque (Nm) at 25 Bar	226	429	529	930	1354
Torque (Nm) at 40 Bar	326	719	1058	1826	2707

FLOW COEFFICIENT Kv (m3 / h) :

DN	100	150	200	250	300	
Percent of rated travel	10%	11.2	25.9	40.6	81.3	130.6
	20%	34.6	84.8	134.9	200.7	326.1
	30%	60.5	145.3	247.4	358.1	550.9
	40%	96.9	206.7	363.3	665.1	813.9
	50%	114.2	270.7	503.4	945.3	1114.8
	60%	139.2	328.7	588.1	1021.4	1415.8
	70%	160.9	379.7	723.9	1252.4	1817.1
	80%	178.2	445.4	857.1	1510.1	2159.6
	90%	175.6	507.7	997.2	2051.5	2381.9
	100%	169.5	519.8	1072.5	2076.6	2419.1

TRIPLE OFFSET LUG BUTTERFLY VALVE PN40

MATERIALS VALVES :

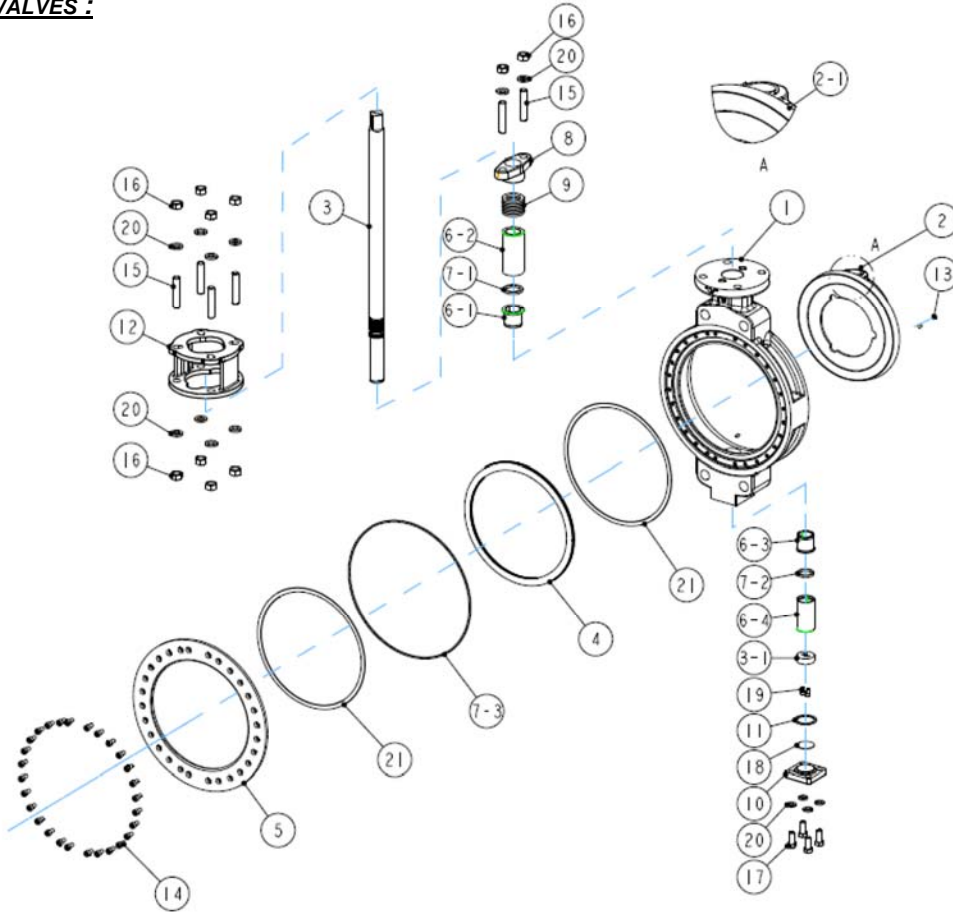

Item	Designation	Materials
1	Body	ASTM A216 WCB
2	Disc	ASTM A351 CF8M
2-1	Disc seat	Stellite Gr.6 Weld overlay
3	Shaft	A479 XM-19
3-1	Shaft stop	
4*	Laminated seat	A479 WM-19 + Graphite
5	Retainer	ASTM A351 CF8
6-1*	Bushing	AISI 316 + RTFE
6-2*		
6-3*		
6-4*		
7-1*	Gasket	Graphite
7-2*		
7-3*		
8	Gland	ASTM A351 CF8
9*	Gland packing	Graphite
10	Bottom cover	ASTM A216 WCB
11*	Bottom cover gasket	Graphite
12	Yoke	ASTM A216 WCB

Item	Designation	Materials
13*	Stop stud	A193 B8M
14	Socket bolt	A193 B8
15	Stud	
16	Nut	A194 8
17	Bolt	A193 B8
18*	Lock plate	AISI 316 + RTFE
19	Socket bolt	A193 B8
20	Spring washer	A240 304
21*	Gasket	Graphite

(* : spare parts)

TRIPLE OFFSET LUG BUTTERFLY VALVE PN40

VALVES SIZE DN100 - 200 (in mm) :

DN 100 – 150

DN200

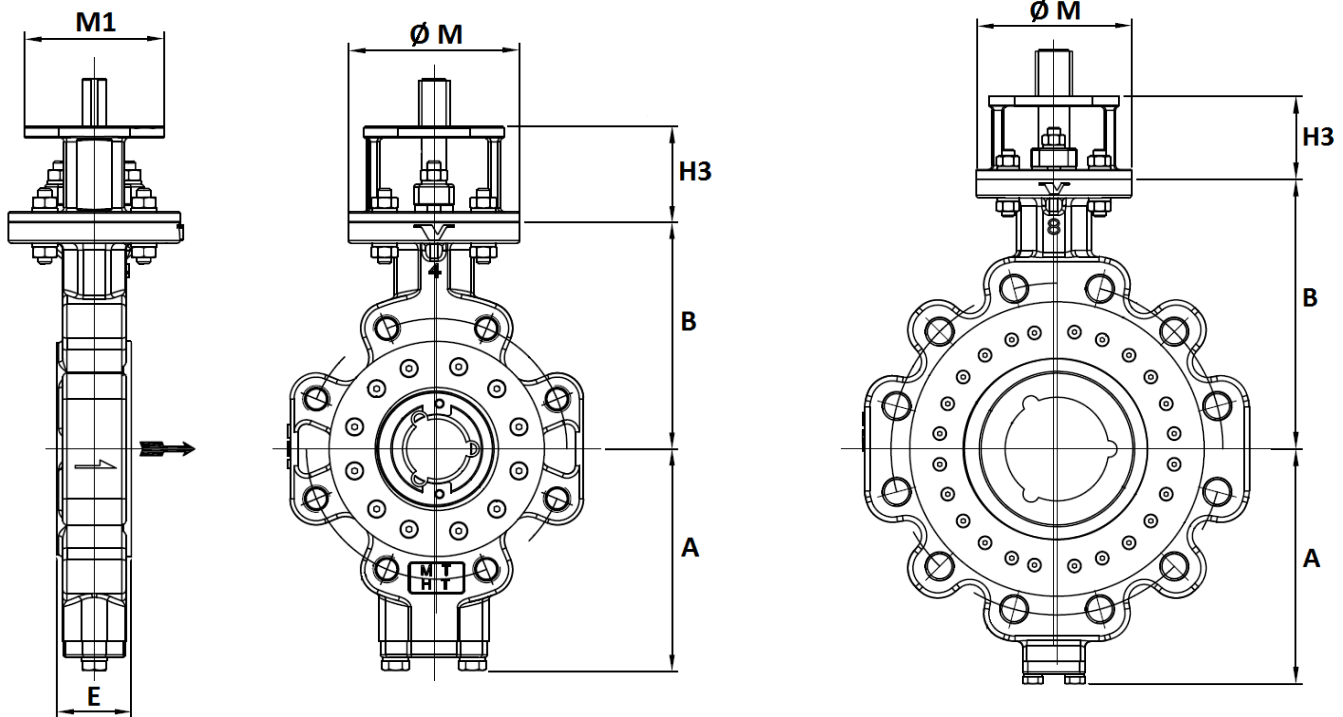

DN	100	150	200
E	54	61	75
A	162	197	227
B	165	215	260
H3	70	70	80
Ø M	125	125	150
M1	102	102	125
Weight (in Kg)	15	22	50

TRIPLE OFFSET LUG BUTTERFLY VALVE PN40

VALVES SIZE DN250 - 300 (in mm) :

DN 250

DN300

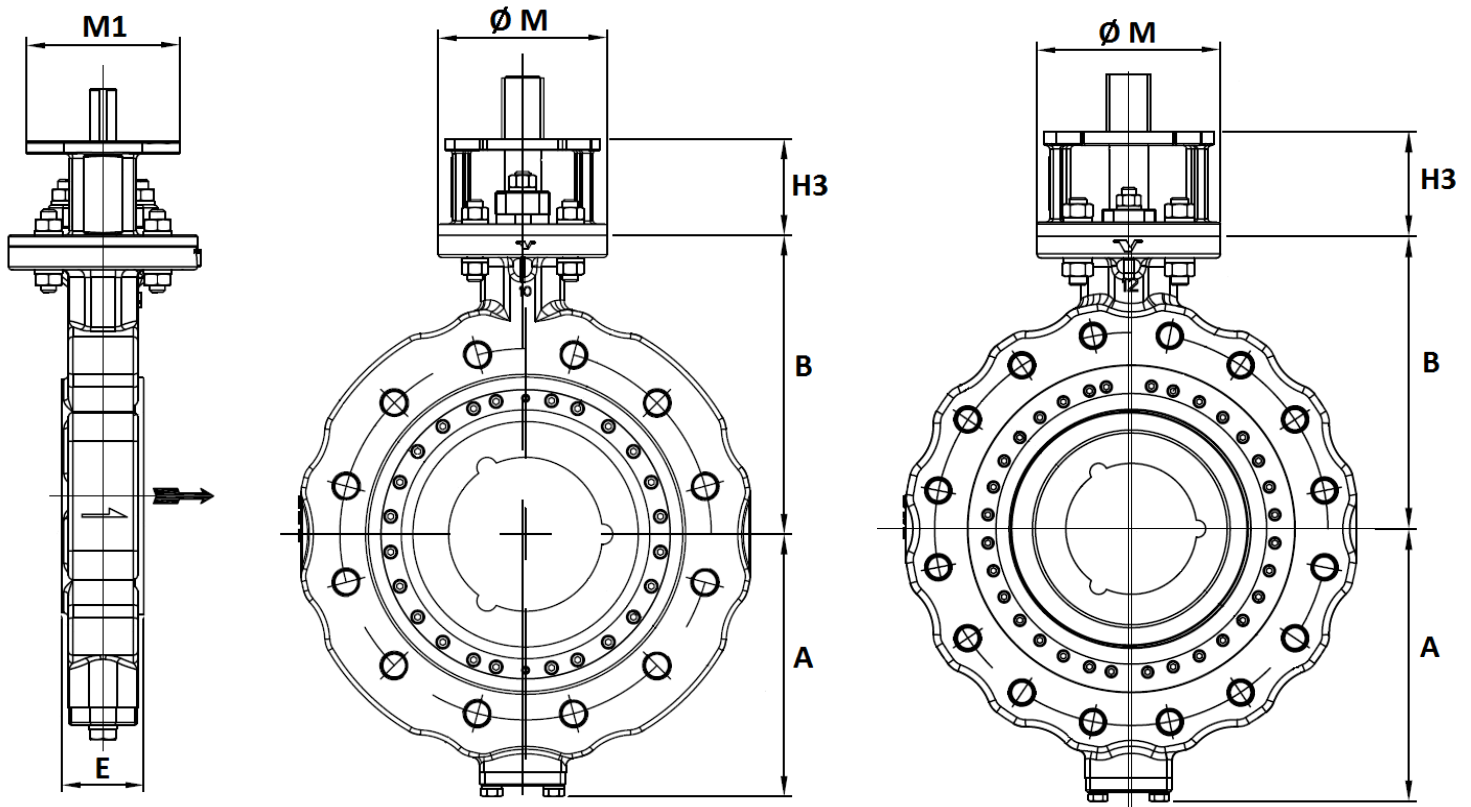

DN	250	300
E	83	92
A	272	312
B	310	335
H3	100	120
Ø M	175	210
M1	140	165
Weight (in Kg)	91	131

TRIPLE OFFSET LUG BUTTERFLY VALVE PN40

GEAR BOX SIZE :

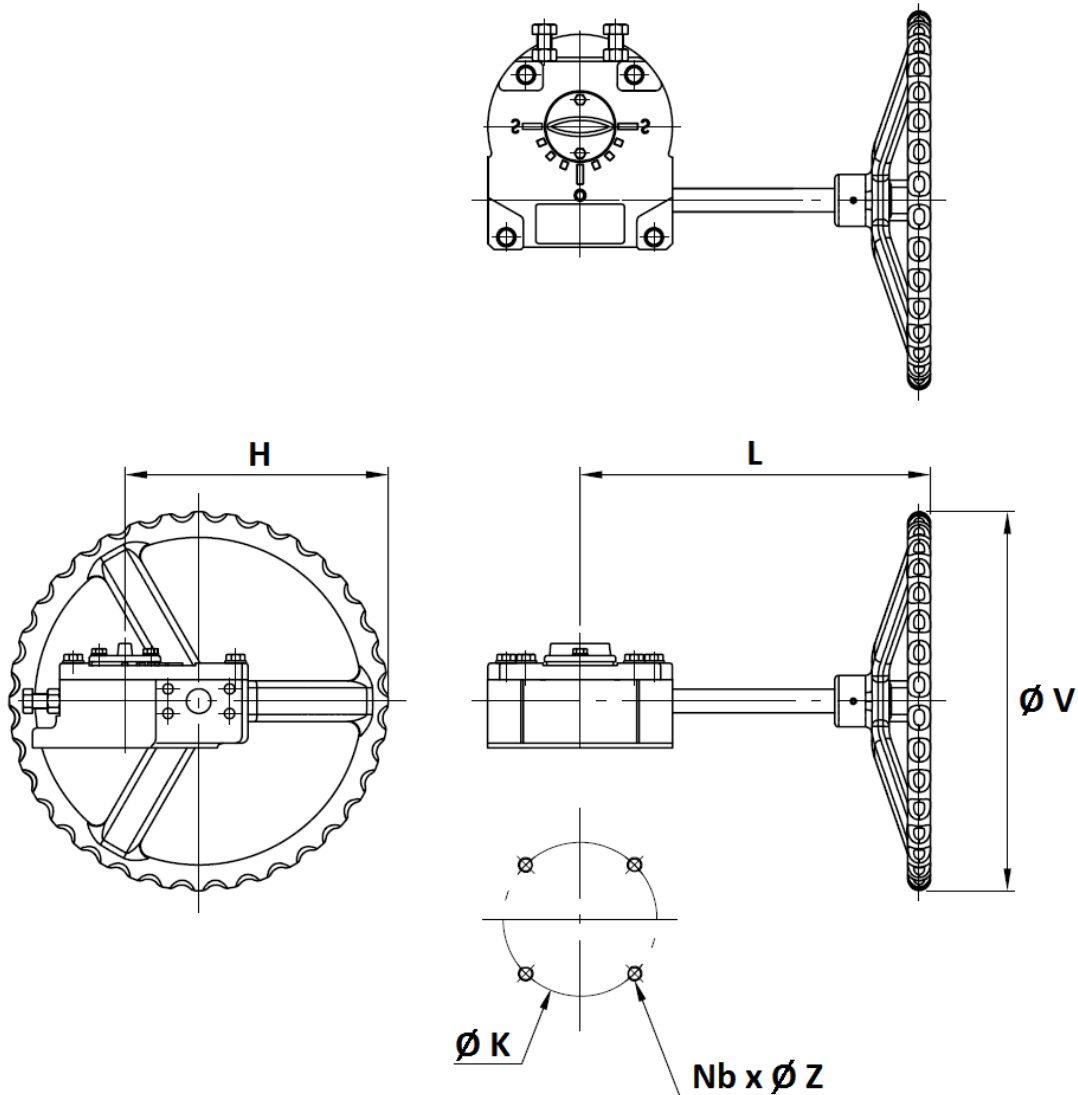

DN	100-150	200	250	300
L	212	285	341	319
H	151	215	284	323
Ø V	200	310	400	400
Ø K	102	125	140	165
ISO	F10	F12	F14	F16
N x Ø Z	4 x M10	4 x M12	4 x M16	4 x M20
Weight (in Kg)	12	14	16	35

TRIPLE OFFSET LUG BUTTERFLY VALVE PN40

ISO PLATE AND STEM SIZE (in mm) :

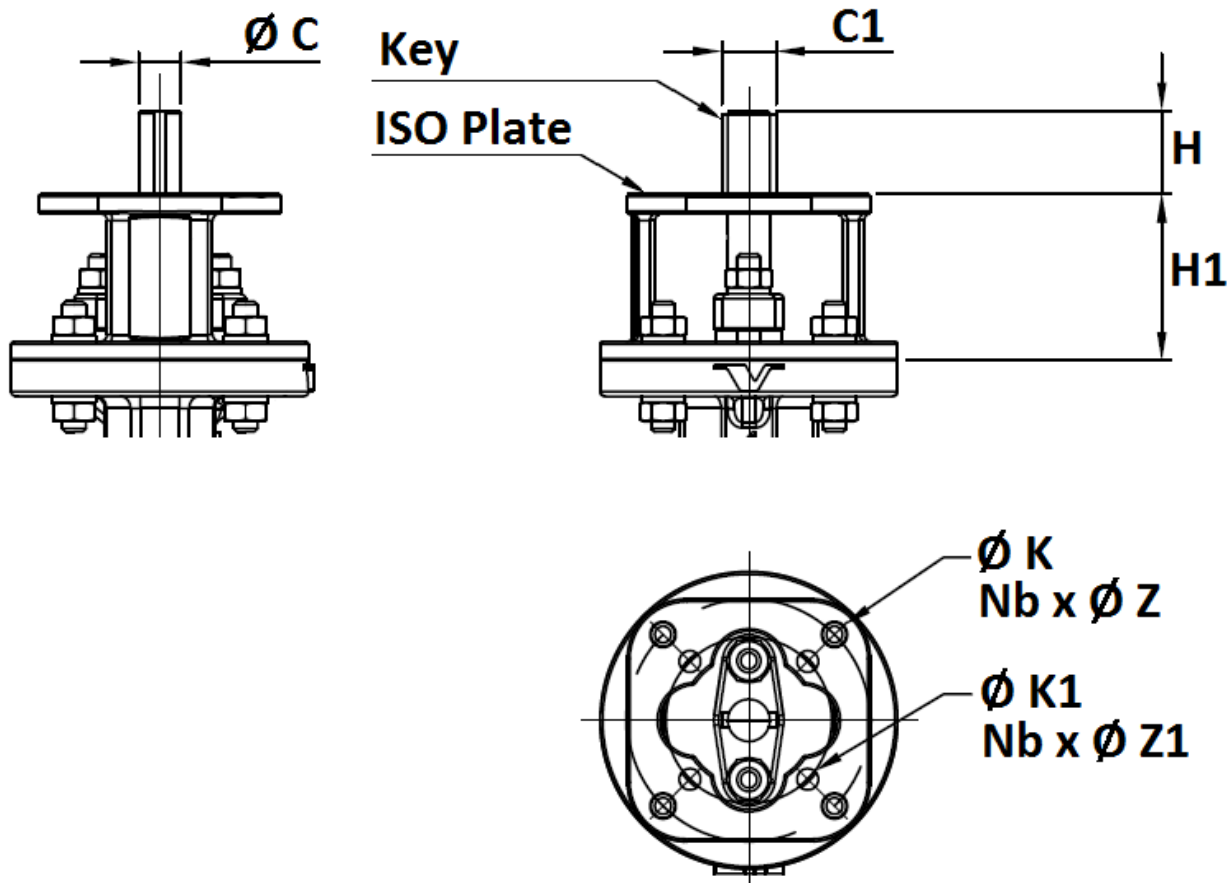

DN	100	150	200	250	300
Ø C	17.9	21.85	29.85	37.7	44.7
C1	22.9	27.85	35.85	43.7	50.7
H	35	45	45	65	65
H1	70	70	80	100	120
Key	6x6x2	8x8x2	8x8x2	10x8x2	12x8x2
Ø K	102	102	125	140	165
ISO	F10	F10	F12	F14	F16
N x ØZ	4 x 11	4 x 11	4 x 14	4 x 18	4 x 22
Ø K1	70	70	102	125	140
ISO1	F07	F07	F10	F12	F14
NxØZ1	4 x 9	4 x 9	4 x 11	4 x 14	4 x 18

TRIPLE OFFSET LUG BUTTERFLY VALVE PN40

SIZE FOR FLANGES CONNECTION PN40 (in mm) :

D100-150

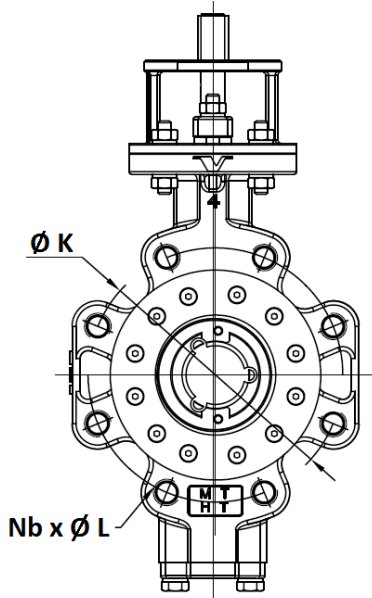

DN200

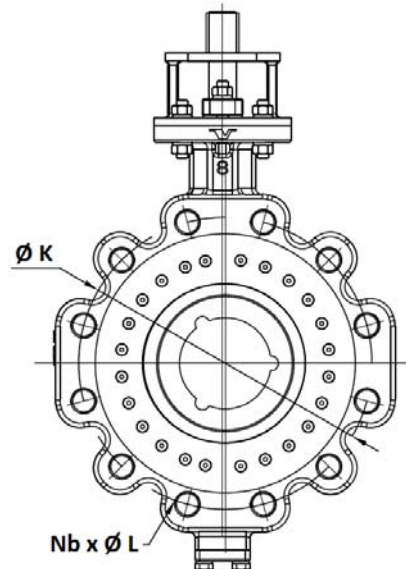

DN250

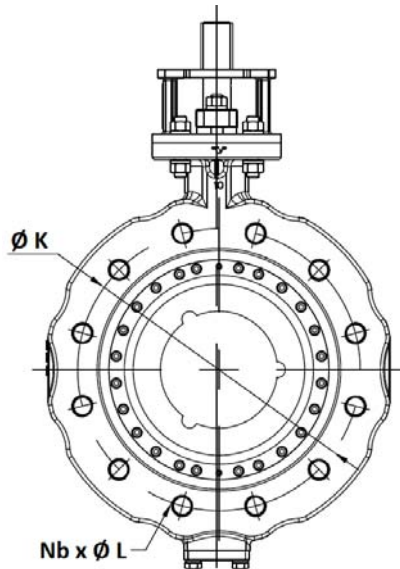

DN300

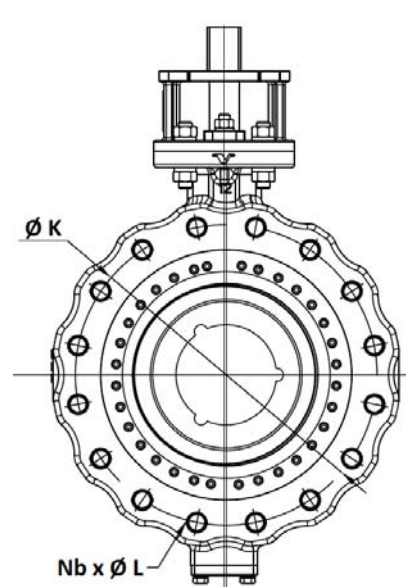

DN	100	150	200	250	300
Ø K	190	250	320	385	450
Nb x Ø L	8 x M20	8 x M24	12 x M27	12 x M30	16 x M30

TRIPLE OFFSET LUG BUTTERFLY VALVE PN40

GEARBOX SPECIFICATIONS :

DN	100	150	200	250	300
Ref.	1191003	1191004	1191005	1191006	1191007
Ratio factor	1 : 32	1 : 32	1 : 36	1 : 62	1 : 70
Number of cycles for opening or closing	8	8	9	16	18
Input torque (Nm)	61	61	109	127	225
Output torque (Nm)	490	490	980	1960	3922

STANDARDS :

- Fabrication according to ISO 9001:2015
- DIRECTIVE 2014/68/EU : CE N° 0035
Risk Category III module H
- Designing according to API 609
- Marking according to MSS SP-25
- Tightness tests according to ISO 5208, Rate A and ANSI FCI 70-2-2006 Class VI
- Between flanges according to EN 1092-1 PN40
- ISO 5211 mounting pad
- Length according to EN 558 series 109 (API 609 table 2 Class 300)
- Fire safe according to ISO 10497 : 2010
- Fugitive Emissions according to EN 15848-1 : 2006, Class C
- ATEX Group II Category 2 G/2D Zone 1 & 21 Zone 2 & 22 according to directive 2014/34/EU (Optional marking)
- SIL2 according to IEC/EN 61508, SIL 3 possible according to installation

ADVICE : Our opinion and our advice are not guaranteed and SFERACO shall not be liable for the consequences of damages. The customer must check the right choice of the products with the real service conditions.

TRIPLE OFFSET LUG BUTTERFLY VALVE PN40

INSTALLATION INSTRUCTIONS

GENERAL GUIDELINES :

- Ensure that the valves to be used are appropriate for the conditions of the installation (type of fluid, pressure and temperature).
- Be sure to have enough valves to be able to isolate the sections of piping as well as the appropriate equipment for maintenance and repair.
- Ensure that the valves to be installed are of correct strength to be able to support the capacity of their usage.
- **Installation of all circuits should ensure that their function can be automatically tested on a regular basis (at least two times a year).**

INSTALLATION INSTRUCTIONS :

- **Before installing the valves, clean and remove any objects from the pipes** (in particular bits of sealing and metal) which could obstruct and block the valves.
- **Ensure that both connecting pipes either side of the valve (upstream and downstream) are aligned (if they're not, the valves may not work correctly).**
- **Make sure that the two sections of the pipe (upstream and downstream) match, the valve unit will not absorb any gaps. Any distortions in the pipes may affect the tightness of the connection, the working of the valve and can even cause a rupture.** To be sure, place the kit in position to ensure the assembling will work.
- **If sections of piping do not have their final support in place, they should be temporarily fixed. This is to avoid unnecessary strain on the valve.**
- Tighten the bolts in cross as the example below :

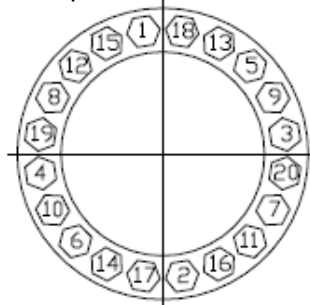

Bolting size	Max torque (Nm)
M16	150
M20	270
M22	434
M24	450
M26	650
M27	700
M28	815
M30	950
M32	1140
M33	1300
M36	1700

TRIPLE OFFSET LUG BUTTERFLY VALVE PN40

INSTALLATION INSTRUCTIONS (SUITE) :

- The disc must move easily inside the pipe.
- Valves must be opened during cleaning operation.
- Vales must be installed in horizontal position or in vertical position with handle at the top :

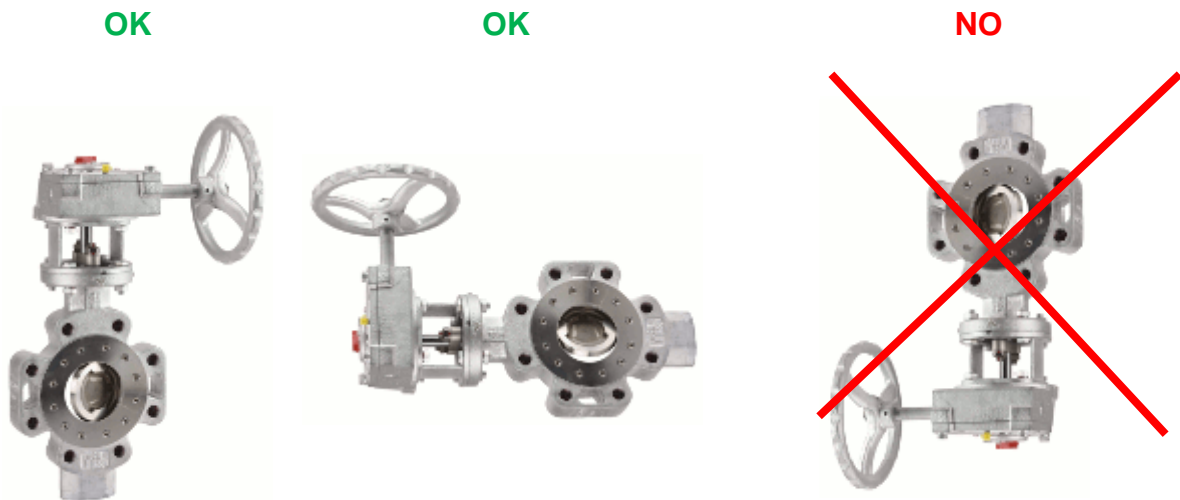

- Tests must be done with a cleaned pipe.
- Tests must be done with opened valve. Test pressure must not be higher than the valve specification according to ISO 5208.
- Then open slowly the valve.
- **Do not mount butterfly valves with stainless steel pressed collars and turning flanges without strias.**
- **And not on flat face flanges without strias (example : painted cast iron fittings)**

MAINTENANCE :

- We recommend to operate fully the valve 1 to 2 times per year.
- During maintenance operation, ensure that the pipe isn't under pressure, that there's no fluid in the pipe and that the valve is isolated. If there's a fluid in the pipe , evacuate it. Ensure that there are no risks due to the temperature or the fluid (like acids). If the fluid is corrosive , inert the installation before maintenance operation.