

**LUG BUTTERFLY VALVE EXCELLENCE RANGE**



Marine & Offshor  
Division



Reinforced lug from DN200 to DN1400 :



Lloyd's  
Register  
ISO 9001 : 2015



Lloyd's  
Register  
PED/2014/68/EU



**Certificate 3.1**

**Size :** DN 32 to 1400 mm  
**Ends :** Between flanges PN10/16  
**Min Temperature :** - 20°C  
**Max Temperature :** + 110°C  
**Max Pressure :** 16 Bars up to DN300  
**Specifications :** Long neck for isolation  
 Lug type  
 Full crossing stem  
 ISO 5211 mounting pad

**Materials :** Ductile iron EN GJS 500-7 body, EPDM seat

\*the installation defects and wear defects are not covered by the guarantee

## LUG BUTTERFLY VALVE EXCELLENCE RANGE

### SPECIFICATIONS :

- Long neck for isolation
- ISO 5211 mounting pad
- Lug type ( reinforced Lug from DN200 to DN1400 )
- Between flanges PN10/16 from DN32/40 to 150, PN10 over
- Between flanges PN16 or Class 150 (PN20) on request
- Full crossing stem
- Removable EPDM seat
- Stainless steel disc
- 9 positions lever with locking device up to DN200 , stop in all positions but non lockable from DN250 to 300
- Rilsan coated body color RAL 5024 , 250-300 microns thickness
- Stem extension 75 mm length ( option )
- Square lever 30x30 mm for special key ( option )

### USE :

- Fluids : Cold and hot water, drinkable water, sea water, alcohol, hydroxyd of soda, demineralized water, mercury, alcalins
- Not advisable : Hydrocarbon, steam, gas, acids, oil, Freon
- For temporary using, can be used at the end of the pipe from DN50 and over ( 6 bars max )
- For final using, can be used at the end of the pipe if assembled with a flange (12 bars max up to DN150, 10 bars over)
- Min and max Temperature Ts : From -20°C to + 110°C
- Max Pressure Ps : 16 bars up to DN300 , 10 bars over (see graphs page 4)

### RANGE :

- With lever from DN 32 to DN 300
- Naked stem from DN 350 to DN1400
- IP65 gear box possible ( **Ref. 1197** ) from DN 32 to DN 1400
- IP65 chain gear box ( **Ref. 1194** ) from DN 32 to DN 500
- On request, stem extension with special length ( **Ref. 98665** )
- On request, CF8M stainless steel handle and bolting **Ref. 9831250-9831264**

### ENDS :

- Between flanges PN10/16 from DN32/40 to 150, PN10 over
- Between flanges PN16 or Class 150 (PN20) on request

### TORQUE VALUES ( in Nm with safety coefficient of 30 % included ) at 16 Bars :

DN	32/40	50	65	80	100	125	150	200	250	300
Torque ( Nm )	9	11	20	29	47	82	130	210	360	475

### TORQUE VALUES ( in Nm with safety coefficient of 30 % included ) at 10 Bars :

DN	32/40	50	65	80	100	125	150	200	250	300
Torque ( Nm )	8	10	14	18	31	59	93	206	330	425

DN	350	400	450	500	600	700	750	800	900	1000	1100	1200	1300	1400
Torque ( Nm )	640	1176	1450	2150	2850	4600	5800	7400	11000	13600	14200	16400	17800	19200

**LUG BUTTERFLY VALVE EXCELLENCE RANGE**
**FLOW COEFFICIENT  $K_v$  (m<sup>3</sup>/h) :**

DN	Opening Angle								
	10°	20°	30°	40°	50°	60°	70°	80°	90°
32-40	3	5	10	16	22	31	36	36	36
50	3	7	15	33	44	48	54	54	54
65	6	10	21	40	57	86	102	102	102
80	7	16	37	56	84	182	246	246	246
100	9	22	51	88	134	187	255	336	336
125	21	33	91	153	232	331	468	560	560
150	45	69	149	281	302	597	822	1015	1072
200	55	131	254	420	631	904	1388	1758	1758
250	64	246	442	710	1056	1522	2128	3096	3096
300	100	275	472	953	1450	2093	2972	4193	4480
350	152	341	766	881	1773	2788	3978	6251	6260
400	182	542	1060	1764	2666	3836	5470	8403	8839
450	227	611	1229	2064	3133	4510	6458	9387	9387
500	342	837	1635	2795	4100	5896	8398	11830	13079
600	432	1143	2286	3833	6187	8369	11916	17917	17917
700	573	1569	3178	5359	8153	11770	16830	26139	26667
750	619	1947	3585	6361	9239	13359	19142	28298	31312
800	723	2167	4148	7008	10674	15426	22085	36080	35850
900	758	2434	4916	8280	12582	18142	25757	39127	39127
1000	1297	3282	6429	10701	16159	23266	33166	51427	51427
1100	1622	3682	7459	12441	19495	29186	36539	64101	68797
1200	1792	4612	9151	15308	23204	33449	41355	69264	76584
1300	2378	5293	10736	17255	28441	41241	53171	71746	84294
1400	2608	6343	12117	21341	31568	45727	65609	75811	117171
1600	3215	6869	14229	25493	35968	56628	77558	86501	137335

**HEAD LOSS CALCULATIONS :**

$$\Delta p = (Q / K_v)^2 \times SG$$

Q : flow in m<sup>3</sup>/h

$\Delta p$  : Head loss in bar

SG : Specific gravity (= 1 for water)

$K_v$  : Volume of water in m<sup>3</sup>/h, that will flow through a given restriction or valve opening with a pressure drop of 1 bar at 20°C)

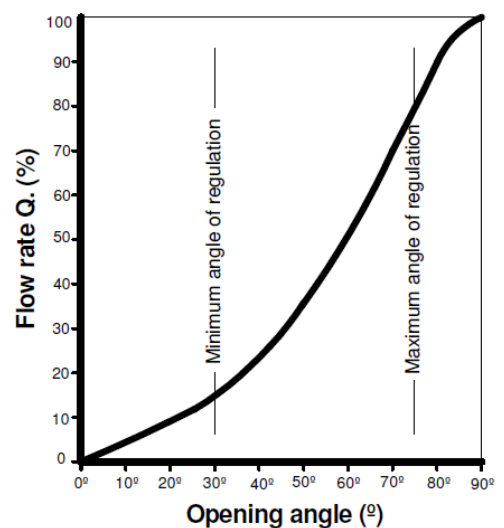

**LUG BUTTERFLY VALVE EXCELLENCE RANGE**

PRESSURE / TEMPERATURE GRAPH (STEAM EXCLUDED) :

- *Ps 16 BAR DN40-300 :*

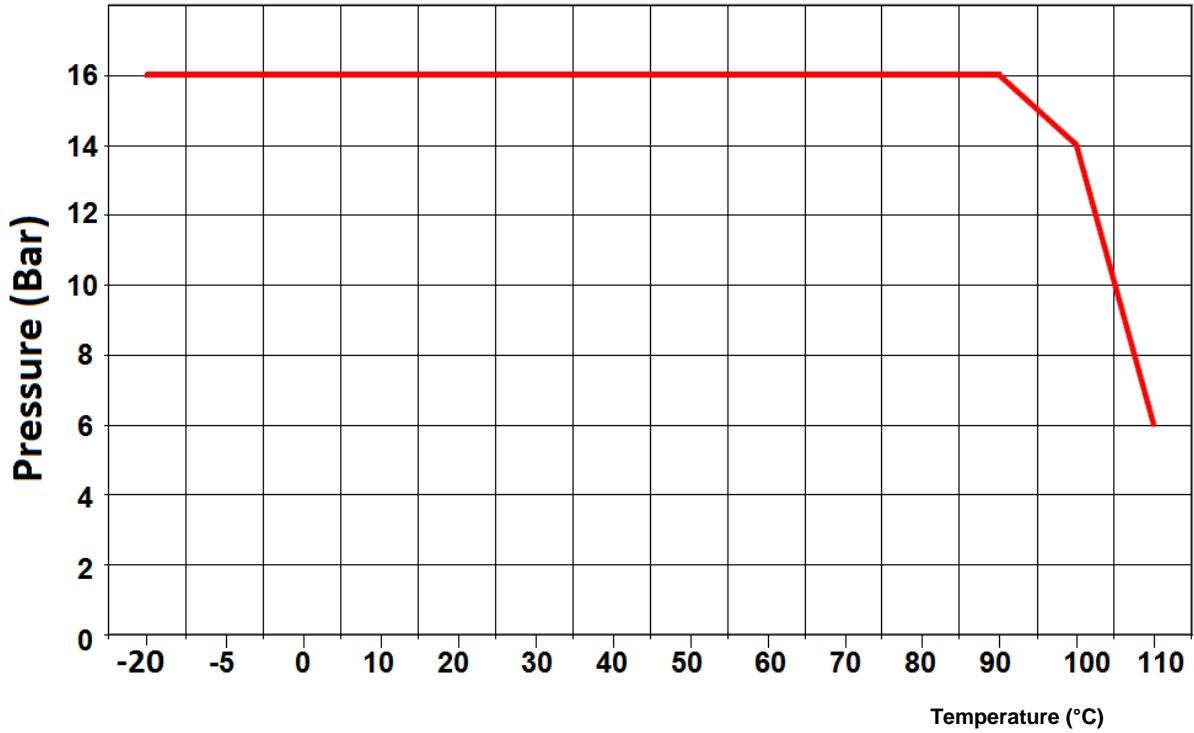

- *Ps 10 BAR DN350-1200 :*

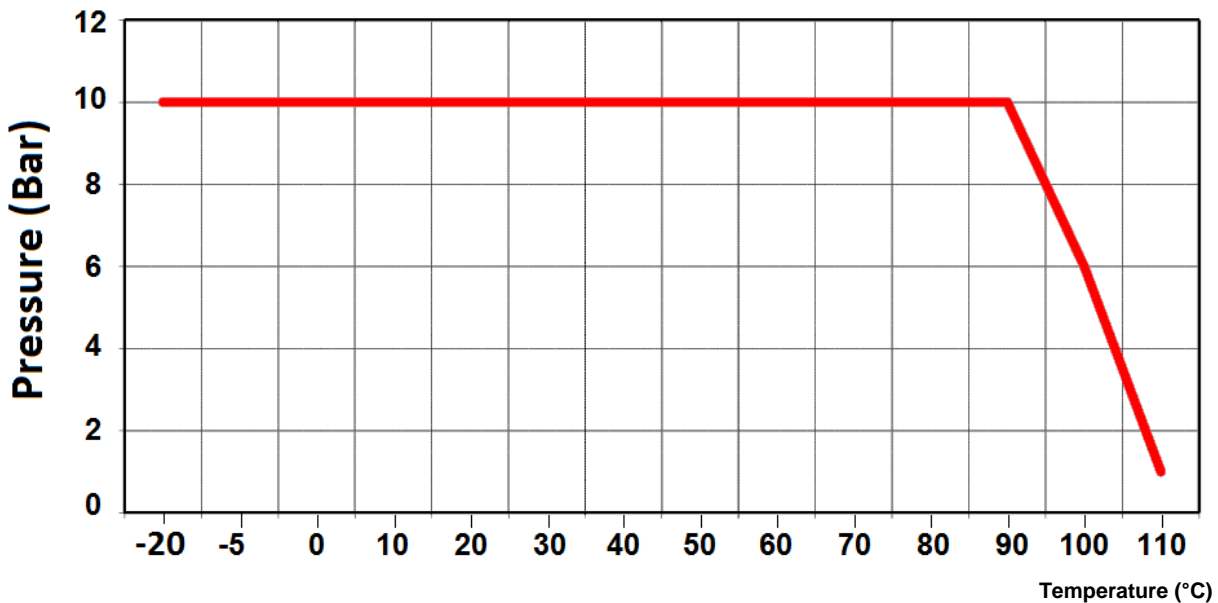

**LUG BUTTERFLY VALVE EXCELLENCE RANGE**

MATERIALS DN 32 - 200 :

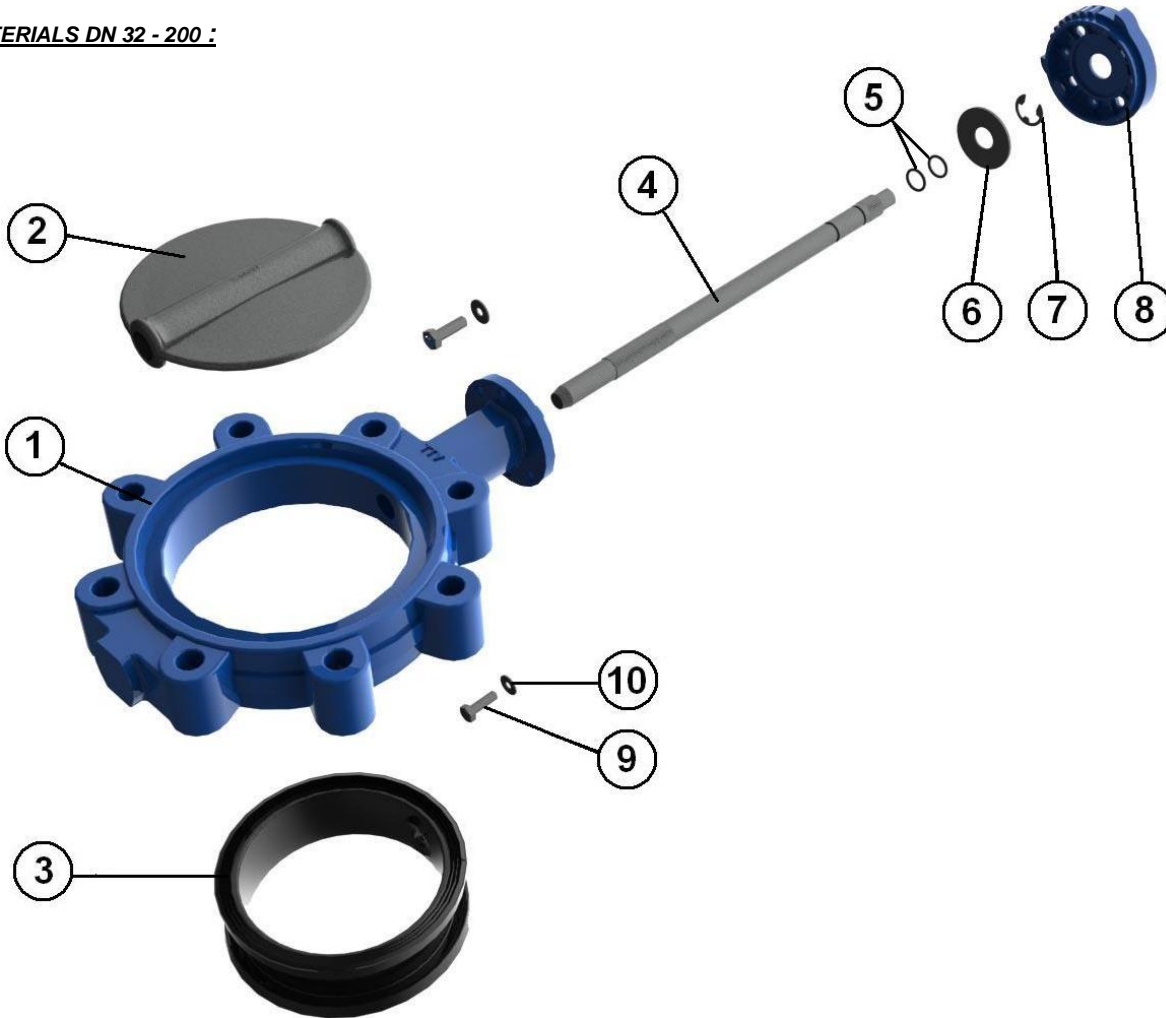

Item	Designation	Materials
1	Body	Ductile iron EN GJS-500-7 rilsan coated color RAL 5024 250-300 μ thickness
2	Disc	ASTM A351 CF8M
3	Seat	EPDM
4	Stem	AISI 304
5	O ring	NBR
6	Ring	Steel
7	Circlips	Steel
8	Plate	Aluminium
9	Plate screw	5.6
10	Washer	Steel
	Lever	Aluminium ADC10 with epoxy painting 50μ thickness

**LUG BUTTERFLY VALVE EXCELLENCE RANGE**

MATERIALS DN 250 - 400 :

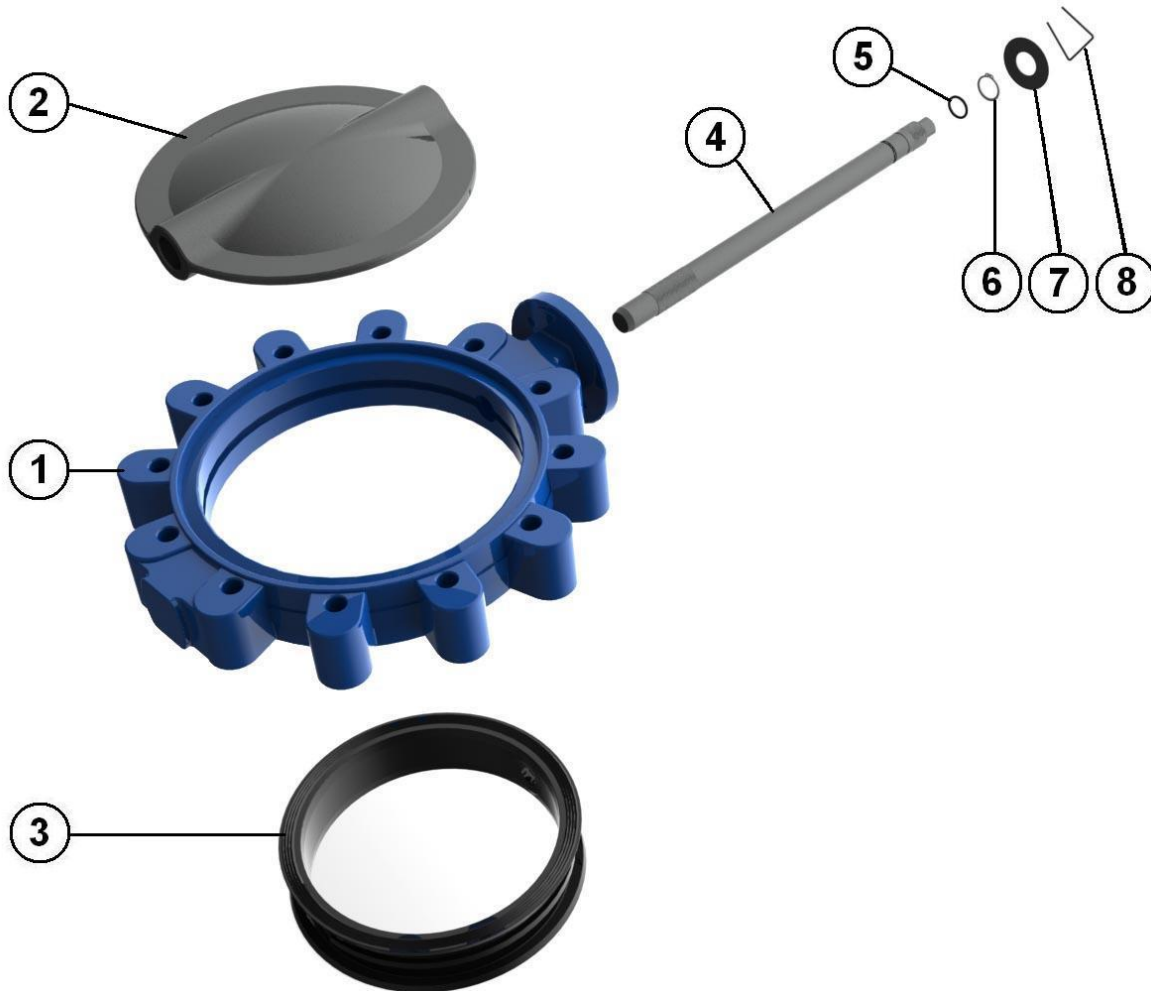

Item	Designation	Materials
1	Body	Ductile iron EN GJS-500-7 rilsan coated color RAL 5024 250-300 μ thickness
2	Disc	ASTM A351 CF8M
3	Seat	EPDM
4	Stem	AISI 304
5	O ring	NBR
6	Circlips	Steel
7	Ring	Steel
8	Spring	Steel
Lever (up to DN300)		Ductile iron EN GJS-500-7 with epoxy painting 50μ thickness

**LUG BUTTERFLY VALVE EXCELLENCE RANGE**

MATERIALS DN 450 - 1400 :

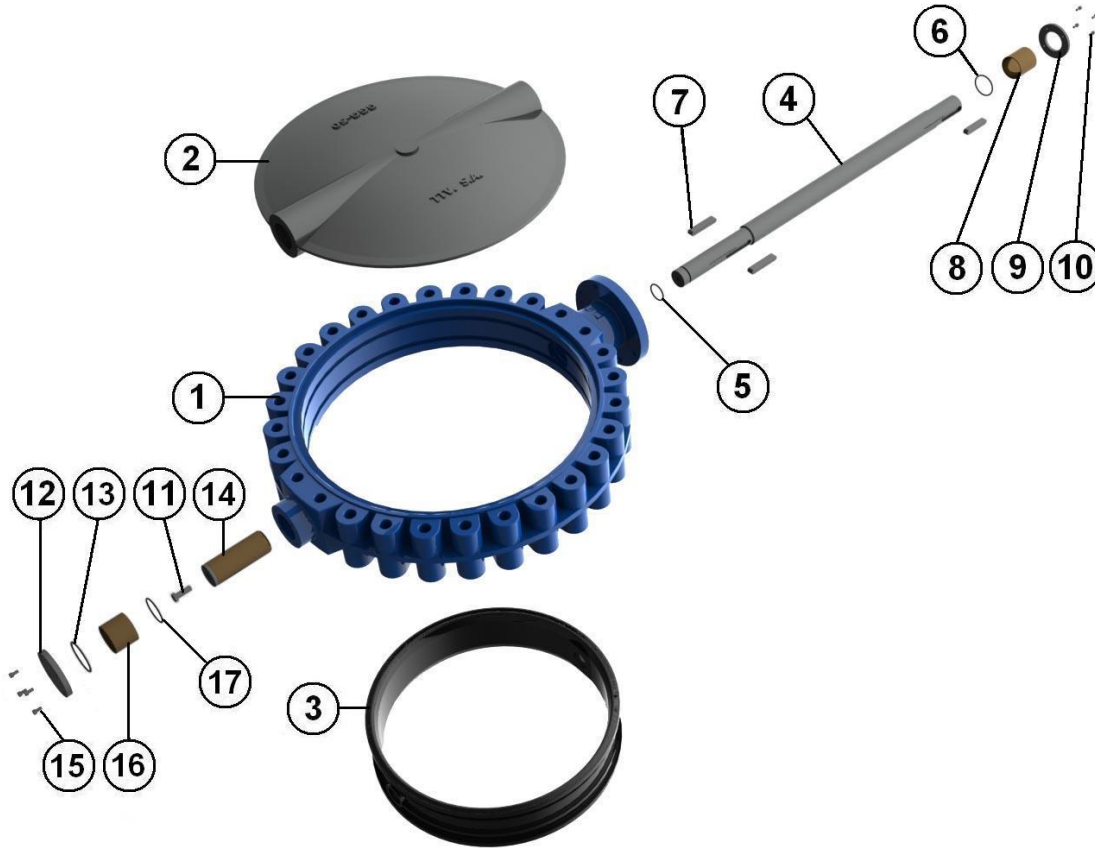

Item	Designation	Materials
1	Body	Ductile iron EN GJS-500-7 rilsan coated color RAL 5024 250-300 μ thickness
2	Disc	ASTM A351 CF8M
3	Seat	EPDM
4	Stem	AISI 304
5	O ring	NBR
6	O ring	NBR
7	Pin	ST – 60
8	Socket	BRONZE
9	Ring	F1110
10	Screw	5.6
11	Screw	5.6
12	Cap	F1110
13	O ring	NBR
14	Socket	F1110
15	Screw	5.6
16	Socket	BRONZE
17	O ring	NBR

**LUG BUTTERFLY VALVE EXCELLENCE RANGE**

**GEARBOX MATERIALS REF. 1197 :**

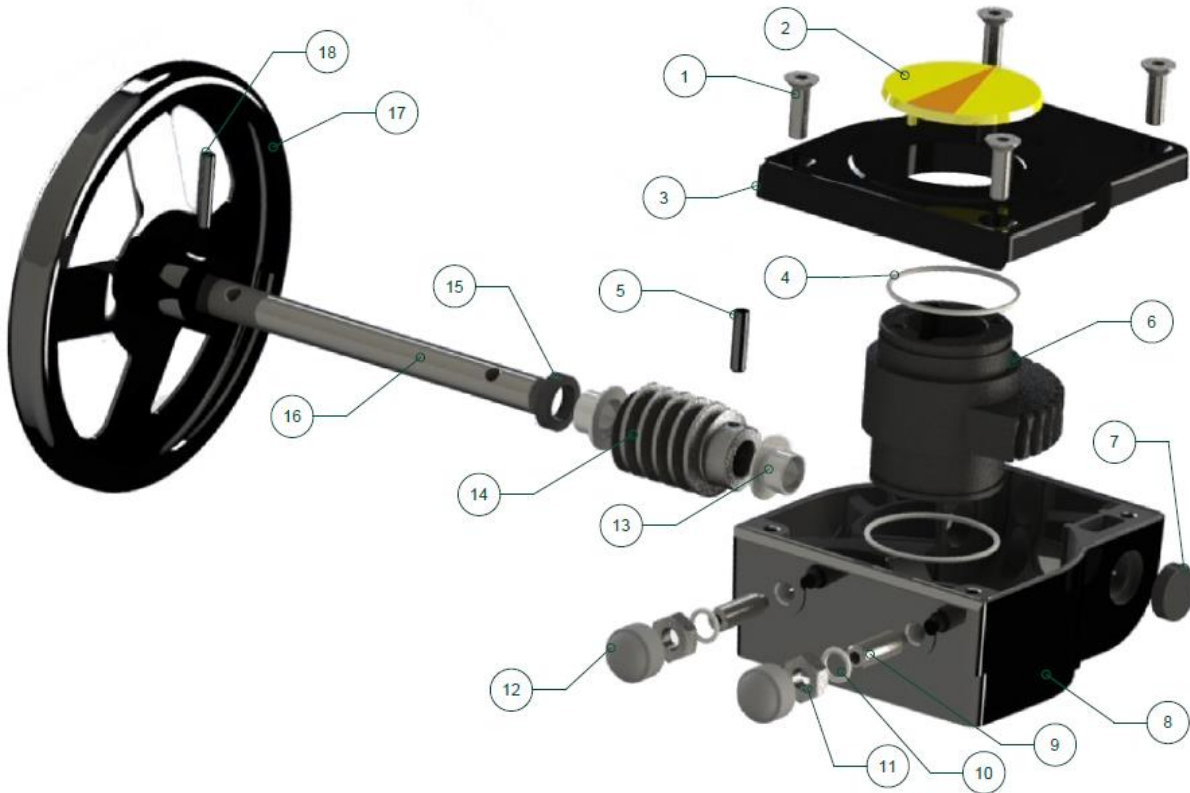

Item	Designation	Materials Ref. 1197
1	Screw	AISI 304
2	Pointer	Polypropylene
3	Bonnet	Aluminium
4	O ring	NBR
5	Pin	Carbon steel
6	Quadrant	Ductile iron EN GJS-400-15
7	Gasket	NBR
8	Body	Aluminium
9	Adjusting bolt	Carbon steel
10	Washer	Galvanized steel
11	Nut	Galvanized steel
12	Cap	NBR 70
13	Bushing	Bronze
14	Worm	Carbon steel 45
15	Gasket	NBR
16	Stem	Carbon steel 45
17	Handwheel	Carbon steel
18	Pin	Carbon steel



**LUG BUTTERFLY VALVE EXCELLENCE RANGE**

**SIZE ( in mm ) :**

- **Valves DN 32 - 150 :**

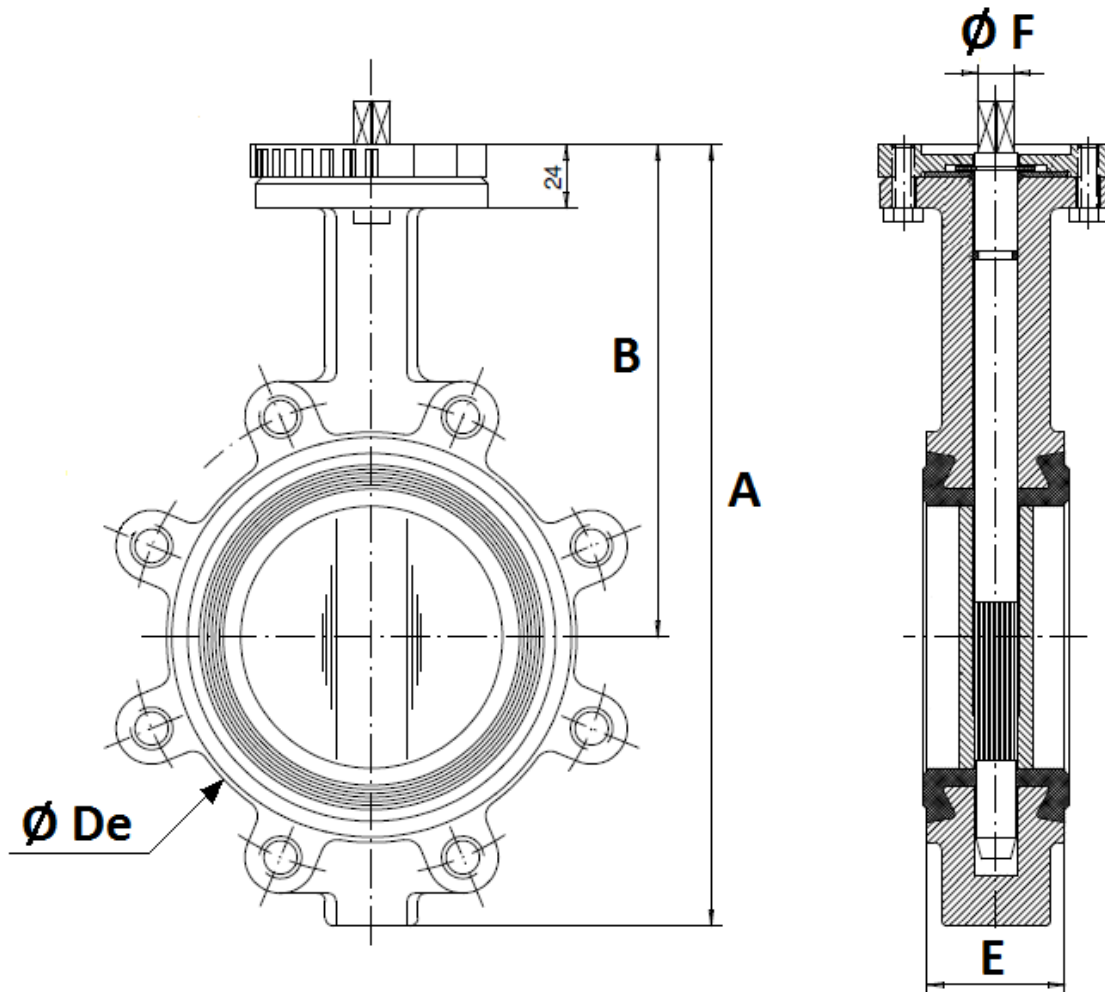

DN	32/40	50	65	80	100	125	150
A	205	226	246	259	295	325	352
B	140	156	161	169	187	206	215
Ø De	83	102	115	136	157	192	220
E	33	43	46	46	52	56	56
Ø F	9.5	9.5	12	14	14	17	17
Weight (Kg)	2.7	4.1	4.7	6.1	7.9	10.9	11.85

**LUG BUTTERFLY VALVE EXCELLENCE RANGE**

**SIZE ( in mm ) :**

- **Valves DN 200 -400 :**

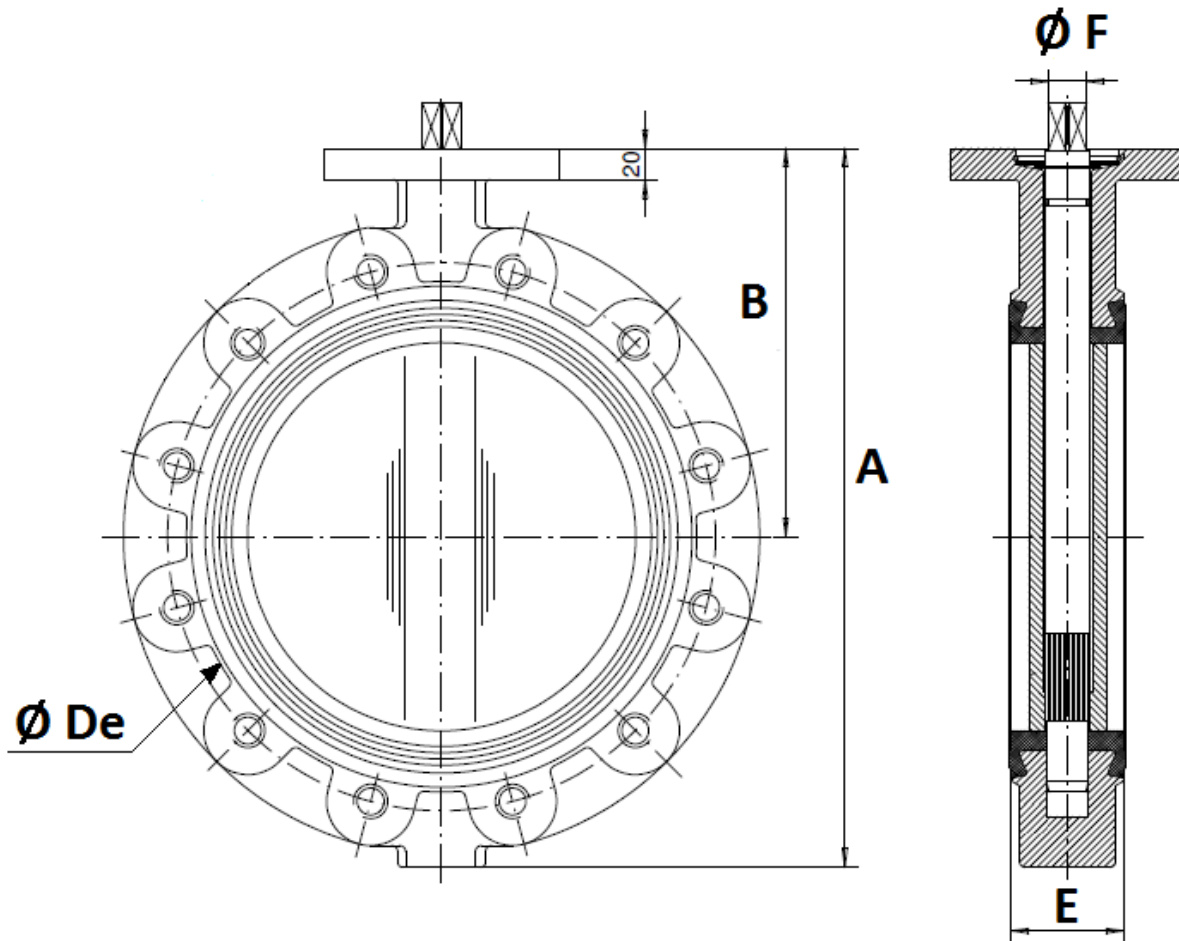

DN	200	250	300	350	400
A	422	460	523	570	644
B	255	248	280	300	340
Ø De	275	329	378	436	487
E	60	68	78	78	102
Ø F	21	23	26.5	26.5	33
Weight (Kg)	18.5	31.8	47.80	53	77

**LUG BUTTERFLY VALVE EXCELLENCE RANGE**

STANDARD LEVERS SIZE ( in mm ) :

**DN 32 – 200 :**

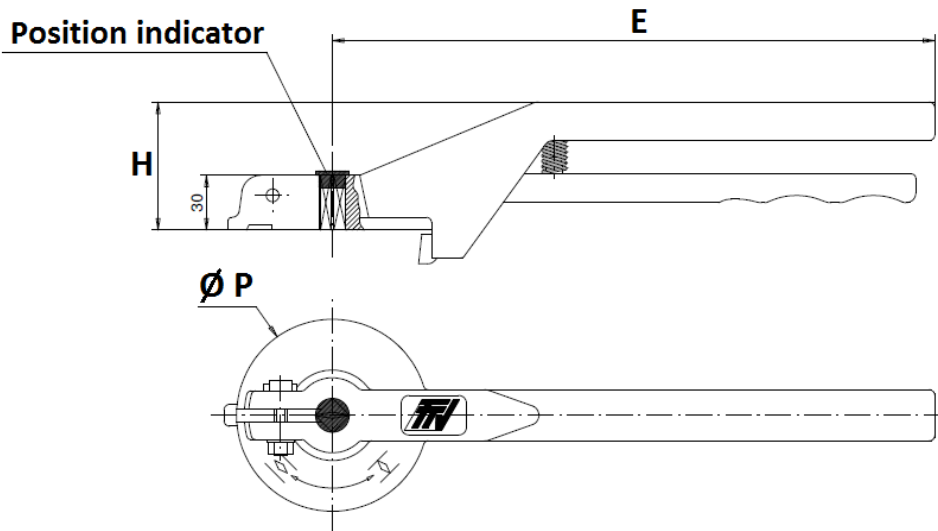

DN	32-100	125-200
E	205	330
H	57	70
Ø P	88	105

**DN 250 – 300 :**

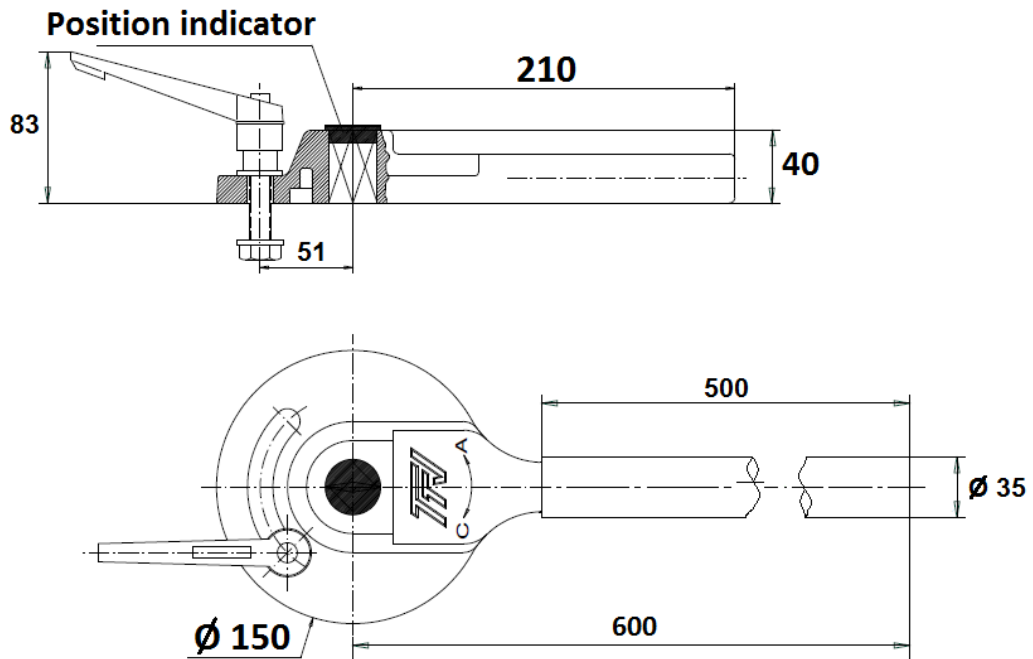

**LUG BUTTERFLY VALVE EXCELLENCE RANGE**

**ASTM A351 CF8M STAINLESS STEEL LEVERS SIZE ( in mm ) ( ON REQUEST ) :**

**DN 40 - 100**

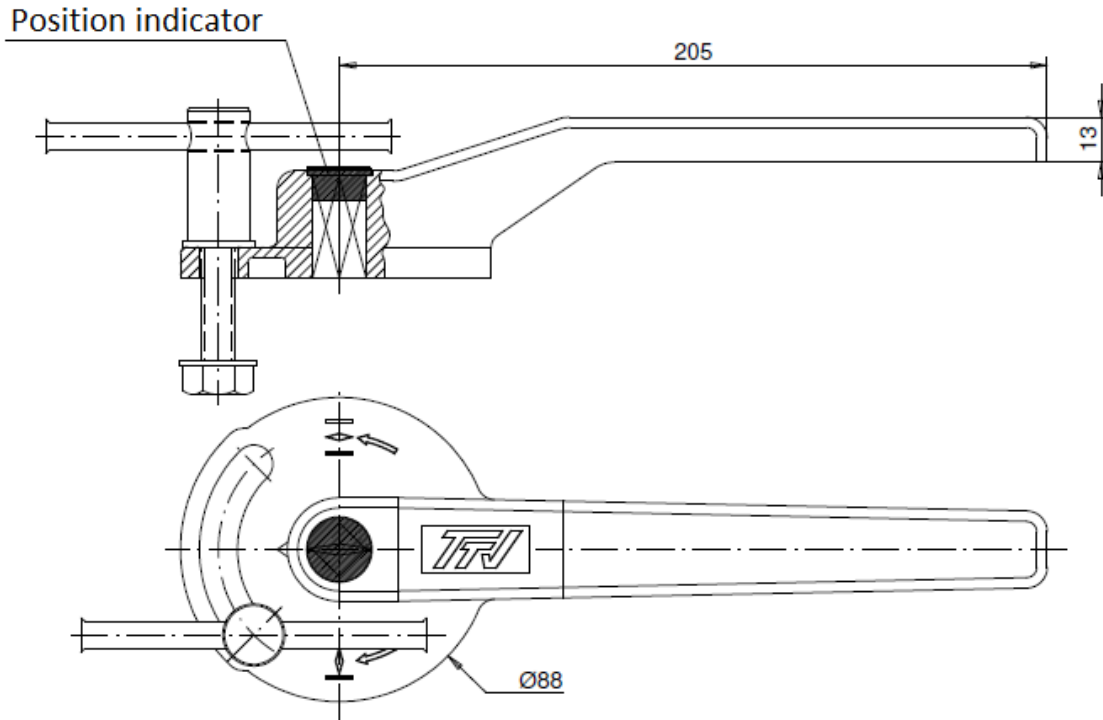

**DN 125 - 200**

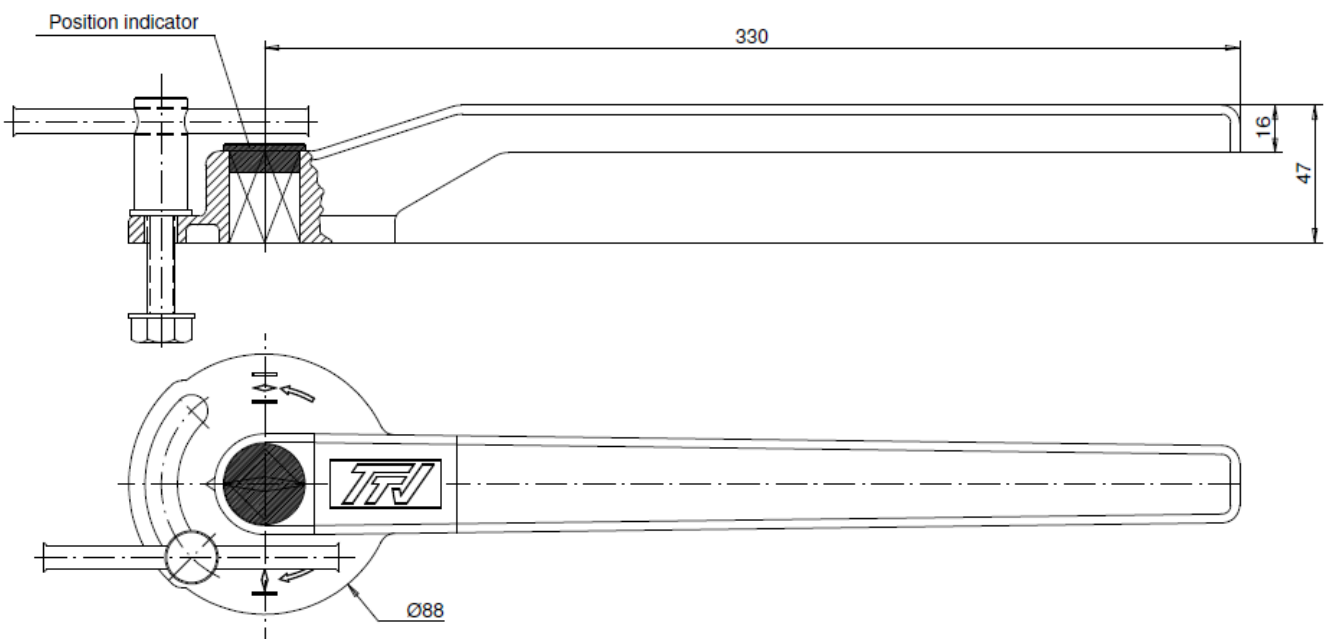

**LUG BUTTERFLY VALVE EXCELLENCE RANGE**

**SIZE ( in mm ) :**

- **Valves DN 450 - 1400 :**

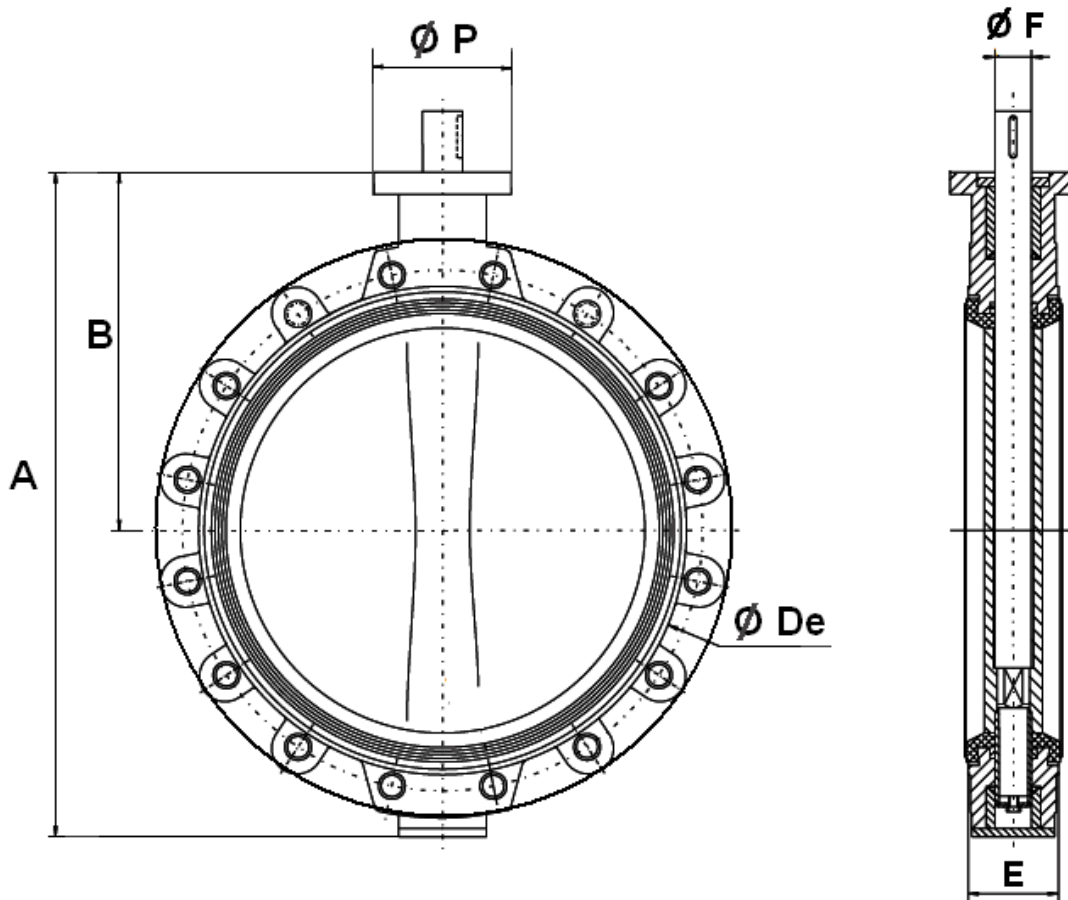

DN	450	500	600	700	750	800	900	1000	1100	1200	1300	1400
A	738	822	965	1100	1150	1248	1325	1457	1580	1720	1910	1990
B	394	440	507	575	600	655	685	754	815	873	1005	1025
Ø De	538	593	695	804	860	911	1010	1124	1225	1330	1460	1530
E	114	127	154	165	190	190	203	216	216	254	360	360
Ø F	50	50	60	60	65	65	80	80	80	100	120	120
Ø P	175	175	250	300	300	300	300	300	300	300	350	350
Weight (Kg)	110	135	210	290	360	450	550	760	1020	1460	2330	2450

**LUG BUTTERFLY VALVE EXCELLENCE RANGE**

ISO MOUNTING PAD SIZE DN32-400 ( in mm ) :

**DN 32 – 200**

**DN250-400**

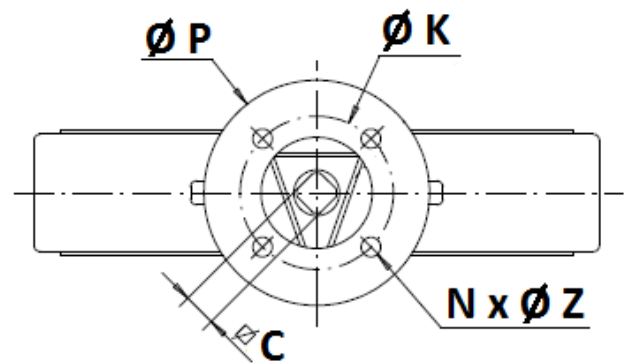
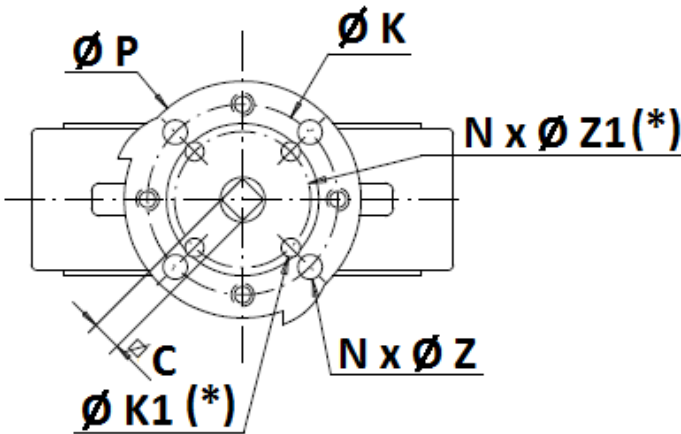
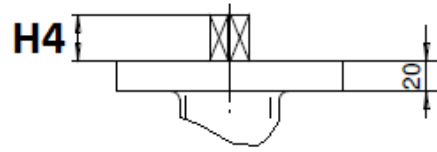
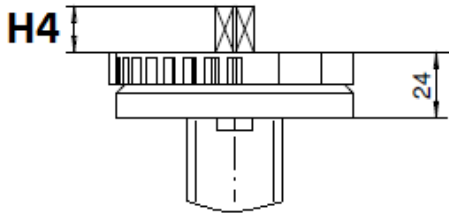

(\*) : Only from DN32 to DN100

DN	32/40	50	65	80	100	125	150	200	250	300	350	400
H4	14	14	16	16	20	20	20	24	24	24	29	29
C	8	8	9	11	11	14	14	17	19	22	22	27
Ø K	70	70	70	70	70	70	70	70	102	102	140	140
ISO	F07	F07	F07	F07	F07	F07	F07	F07	F10	F10	F14	F14
N x Ø Z	4 x 9	4 x 9	4 x 9	4 x 9	4 x 9	4 x 9	4 x 9	4 x 9	4 x 11	4 x 11	4 x 18	4 x 18
Ø K1	50	50	50	50	50	-	-	-	-	-	-	-
ISO 1	F05	F05	F05	F05	F05	-	-	-	-	-	-	-
N x Ø Z1	4 x 7	4 x 7	4 x 7	4 x 7	4 x 7	-	-	-	-	-	-	-

**LUG BUTTERFLY VALVE EXCELLENCE RANGE**

ISO MOUNTING PAD SIZE DN450-1400 ( in mm ) :

**DN 450 - 1400**

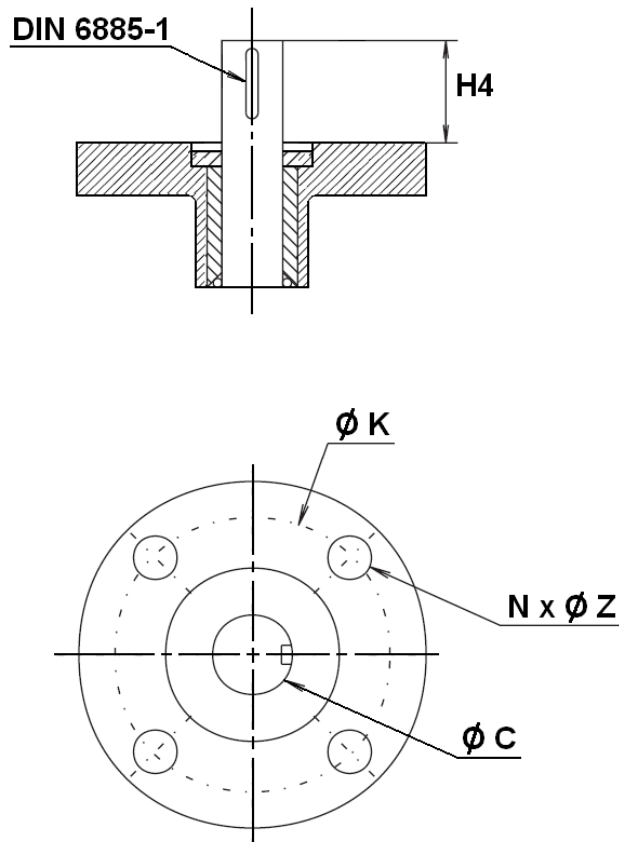

DN	450	500	600	700	750	800	900	1000	1100	1200	1300	1400
H4	80	80	90	90	110	110	110	110	110	110	120	120
Ø C	50	50	60	60	65	65	80	80	80	100	120	120
Ø K	140	140	165	254	254	254	254	254	254	254	298	298
ISO	F14	F14	F16	F25	F25	F25	F25	F25	F25	F25	F30	F30
N x Ø Z	4 x 18	4 x 18	4 x 22	8 x 18	8 x 18	8 x 18	8 x 18	8 x 18	8 x 18	8 x 18	8 x 22	8 x 22

**LUG BUTTERFLY VALVE EXCELLENCE RANGE**

**SIZE ( in mm ) :**

- **Valves with gear box DN 32 - 400 :**

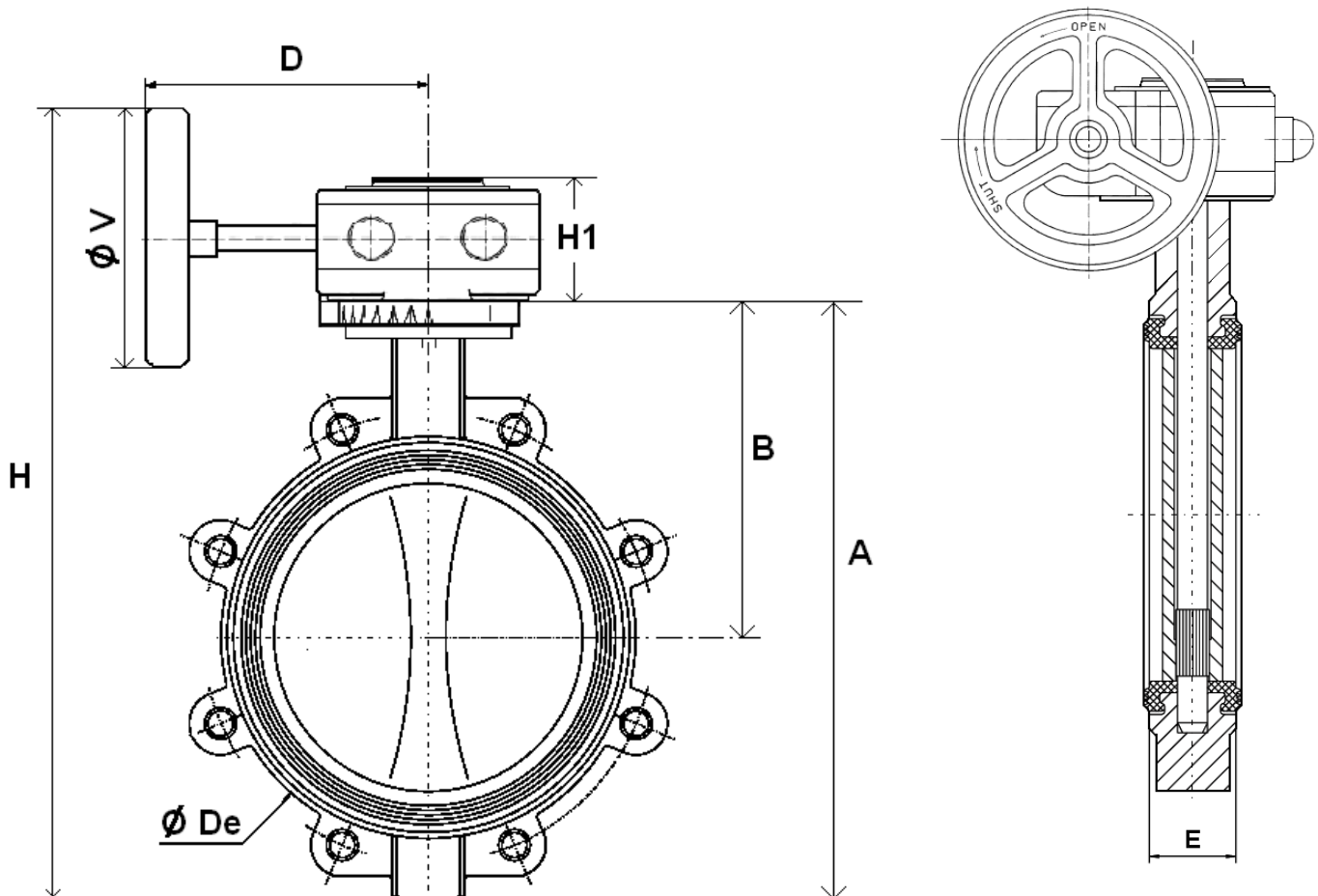

DN	32/40	50	65	80	100	125	150	200	250	300	350	400
A	205	226	246	259	295	325	352	422	460	523	570	644
B	140	156	161	169	187	206	215	255	248	280	300	340
$\phi De$	83	102	115	136	157	192	220	275	329	378	436	487
D	120	120	120	120	120	136	136	136	223	223	345	345
E	33	43	46	46	52	56	56	60	68	78	78	102
H	303	322	339	354	392	455	482	566	648	710	829	909
H1	58	58	58	58	58	58	58	58	74	74	98	98
$\phi V$	140	140	140	140	140	200	200	200	300	300	400	400
Weight (Kg)	4.05	5.45	6.05	7.45	9.25	12.65	13.6	20.25	35.8	51.8	62.5	86.5



**LUG BUTTERFLY VALVE EXCELLENCE RANGE**

**SIZE ( in mm ) :**

- **Valves with gear box DN 450 - 1400 :**

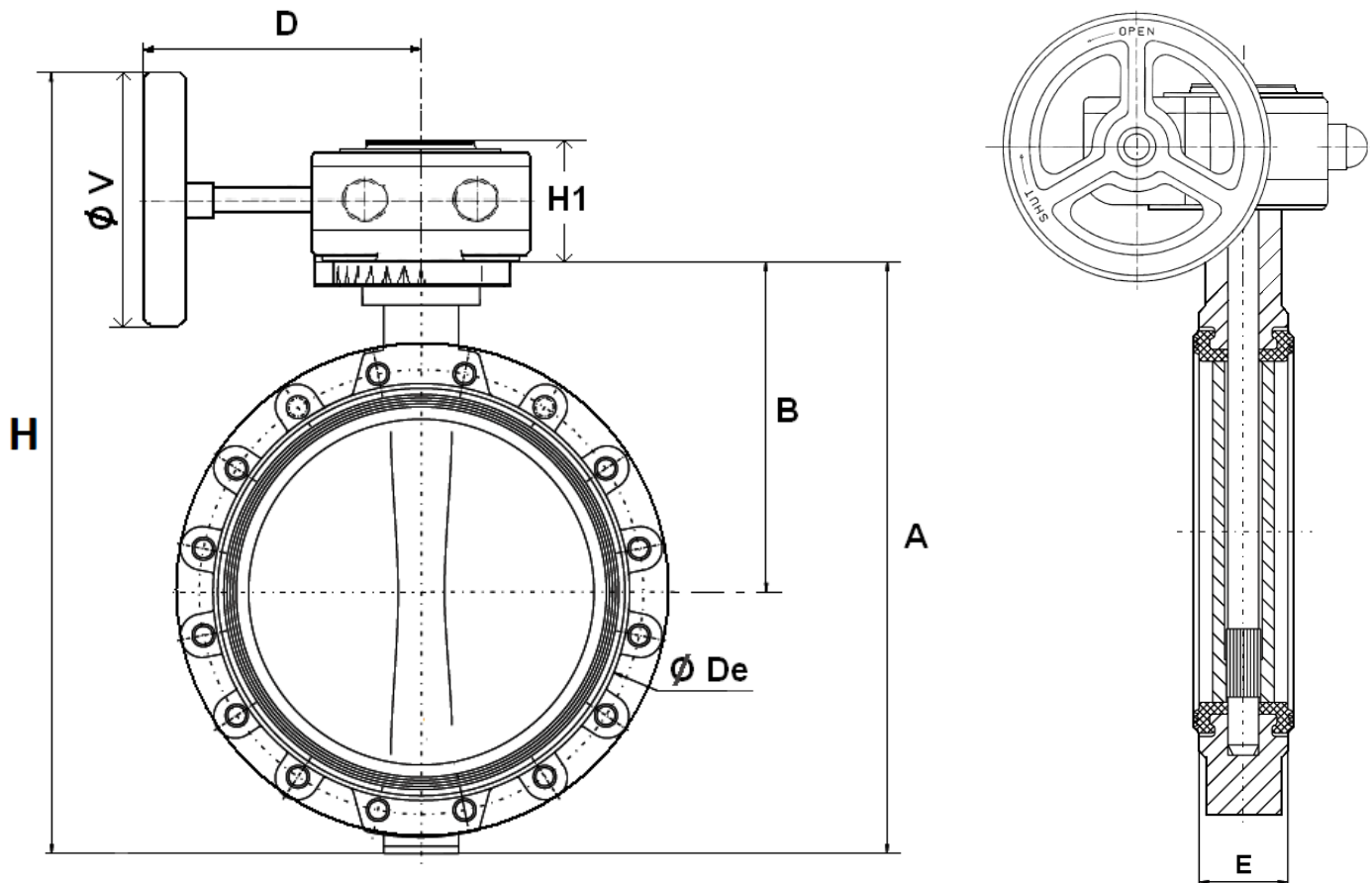

DN	450	500	600	700	750	800	900	1000	1100	1200	1300	1400
A	738	822	965	1100	1150	1248	1325	1457	1580	1720	1910	1990
B	394	440	507	575	600	655	685	754	815	873	1005	1025
Ø De	538	593	695	804	860	911	1010	1124	1225	1330	1460	1530
D	364	386	421	440	440	438	492	492	492	550	605	605
E	114	127	154	165	190	190	203	216	216	254	360	360
H	1083	1171	1376	1409	1459	1657	1688	1820	1943	2178	2260	2429
H1	90	98	122	117	117	117	125	125	125	115	178	178
Ø V	600	600	700	500	500	700	600	600	600	800	700	700
Weight (Kg)	128.8	161.8	248.3	339	409	501.3	624.8	834.8	1094.8	1546.5	2562	2682

Sferaco 90 rue du Ruisseau 38297 St Quentin Fallavier Tel: + 33 (0) 474.94.15.90 Fax: + 33 (0) 474.95.62.08 Internet: [www.sferaco.fr](http://www.sferaco.fr) E-mail: [sferaco@sferaco.fr](mailto:sferaco@sferaco.fr)

Date : 04/19

**LUG BUTTERFLY VALVE EXCELLENCE RANGE**

**SIZE ( in mm ) :**

- **Valves with chain gear box :**

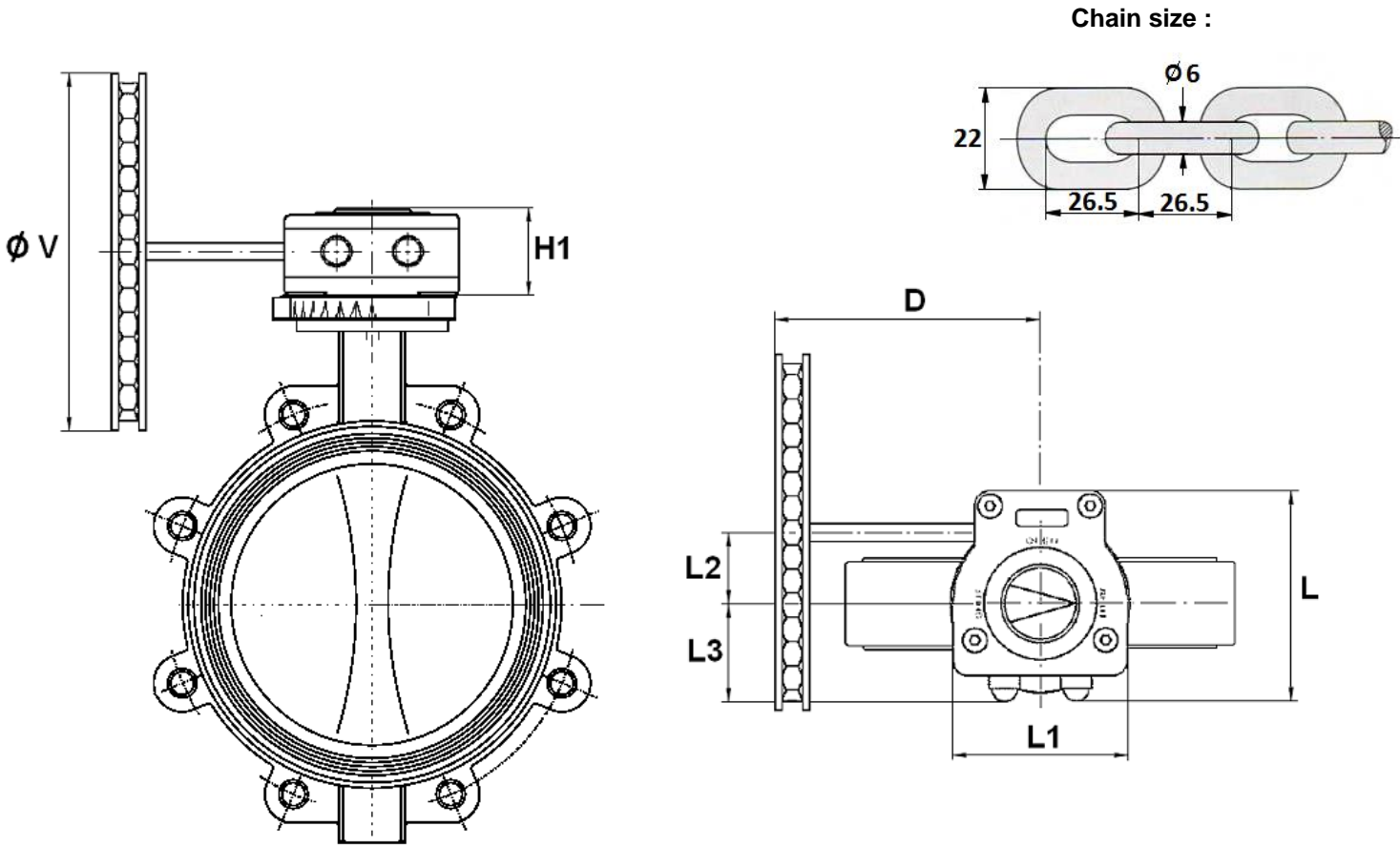

DN	32/40	50	65	80	100	125	150	200	250	300	350	400	450	500
D	120	120	120	120	120	126	126	126	214	214	331	331	350	365
H1	58	58	58	58	58	58	58	58	74	74	98	98	90	98
L	128	128	128	128	128	128	128	128	175	175	224	224	232	267
L1	100	100	100	100	100	100	100	100	142	142	185	185	204	227
L2	50	50	50	50	50	50	50	50	61	61	80	80	86	104.5
L3	56	56	56	56	56	56	56	56	80	80	98	98	100	110
Ø V	160	160	160	160	160	210	210	210	300	300	400	400	500	500
Weight (Kg)	5.05	6.45	7.05	8.45	10.25	13.65	14.6	21.25	38.6	54.6	67.3	91.3	136.2	168.7

**LUG BUTTERFLY VALVE EXCELLENCE RANGE**
**GEARBOX SPECIFICATIONS :**

DN	32/50	65	80/100	125/150	200	250	300	350
Ref.	1197050	1197065	1197100	1197150	1197200	1197250	1197300	1197350
Ratio factor	37 : 1	37 : 1	37 : 1	37 : 1	37 : 1	36 : 1	36 : 1	50 : 1
Turns number for closing / opening	9.25	9.25	9.25	9.25	9.25	9	9	12.5
Input torque (Nm)	12.5	12.5	12.5	12.5	12.5	23	23	50
Output torque (Nm)	300	300	300	300	300	675	675	1310

DN	400	450	500	600	700	800	900	1000
Ref.	1197400	1197451	1197501	1197601	1197700	1197800	-	-
Ratio factor	50 : 1	38 : 1	55 : 1	52 : 1	208 : 1	208 : 1	312 : 1	312 : 1
Turns number for closing / opening	12.5	9.5	13.75	13	52	52	78	78
Input torque (Nm)	50	86	96	160	65	65	80	80
Output torque (Nm)	1310	1620	2640	4160	6800	6800	12500	12500

DN	1200	1300	1400
Ratio factor	702 : 1	720 : 1	720 : 1
Turns number for closing / opening	175.5	180	180
Input torque (Nm)	50	91	91
Output torque (Nm)	17000	32000	32000

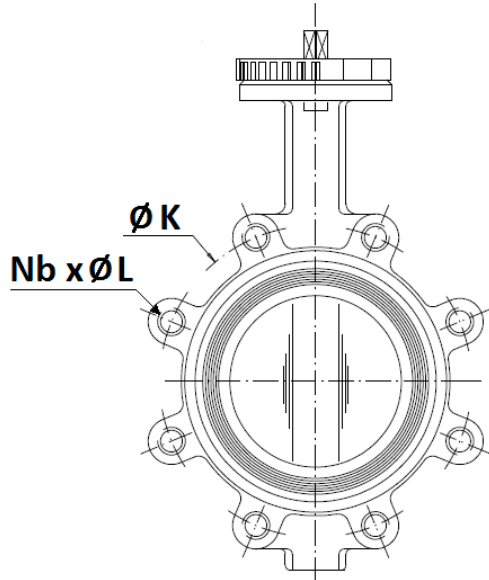
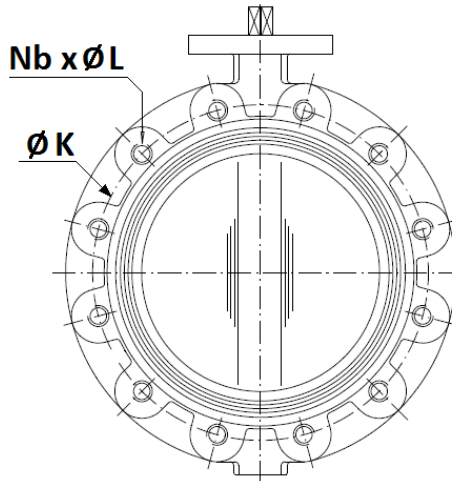
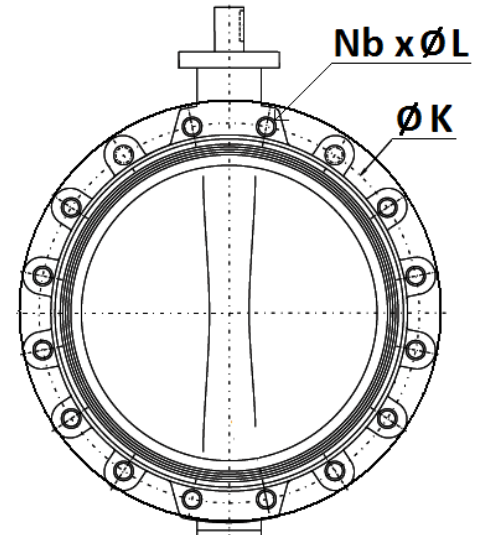
**LUG BUTTERFLY VALVE EXCELLENCE RANGE**
**BETWEEN FLANGES SIZE ( in mm ) :**
**DN 32-150**

**DN200 – 400**

**DN450-1400**

	DN (mm)	32	40	50	65	80	100	125	150	200	250	300	350	400
	NPS ( " )	1"1/4	1"1/2	2"	2"1/2	3"	4"	5"	6"	8"	10"	12"	14"	16"
PN10	Ø K	100	110	125	145	160	180	210	240	295	350	400	460	515
	Nb x Ø L	4 x M16				8 x M16			8 x M20		12 x M20	16x M20	16x M24	
PN16	Ø K	100	110	125	145	160	180	210	240	295	355	410	470	525
	Nb x Ø L	4 x M16				8 x M16			8xM20	12xM20	12 x M24	16x M24	16x M27	
Class 150	Ø K	88.9	98.5	120.6	139.7	152.4	190.5	215.9	241.3	298.5	362	431.8	476.3	539.8
	Nb x Ø L	4 x 1/2"		4 x 5/8"			8x5/8"	8 x 3/4"			12 x 7/8"		12 x 1"	16 x 1"

	DN (mm)	450	500	600	700	750	800	900	1000	1100	1200	1300	1400
	NPS ( " )	18"	20"	24"	28"	30"	32"	36"	40"	44"	48"	52"	56"
PN10	Ø K	565	620	725	840	900	950	1050	1160	1270	1380	-	1590
	Nb x	20 x		20 x	24	24	24	28	28	32	32		36
	Ø L	M24		M27	M27	M30	M30	M30	M33	M33	M36	-	M39
PN16	Ø K	585	650	770	840	900	950	1050	1170	1270	1390	-	1590
	Nb x	20	20	20	24	24	24	28	28	32	32		36
	Ø L	M27	M30	M33	M33	M33	M36	M36	M39	M39	M45	-	M45
Class 150	Ø K	577.9	635	749.3	863	914	978	1086	1200	1314	1422	1537	1651
	Nb x	16	20	20	28	28	28	32	36	40	44	44	48
	Ø L (BSW)*	1 1/8"	1 1/8"	1 1/4"	1 1/4"	1 1/4"	1 1/2"	1 1/2"	1 1/2"	1 1/2"	1 1/2"	1 3/4"	1 3/4"
	Nb x	16	20	20	28	28	28	32	36	40	44		
	Ø L (Metric)	M30	M30	M33	M33	M33	M39	M39	M39	M39	M39		

\* Threaded BSW on standard, on request metric threaded for Class 150

 Sferaco 90 rue du Ruisseau 38297 St Quentin Fallavier Tel: + 33 (0) 474.94.15.90 Fax: + 33 (0) 474.95.62.08 Internet: [www.sferaco.fr](http://www.sferaco.fr) E-mail: [sferaco@sferaco.fr](mailto:sferaco@sferaco.fr)

**LUG BUTTERFLY VALVE EXCELLENCE RANGE**

**DEPTH THREADED HOLES (in mm) :**

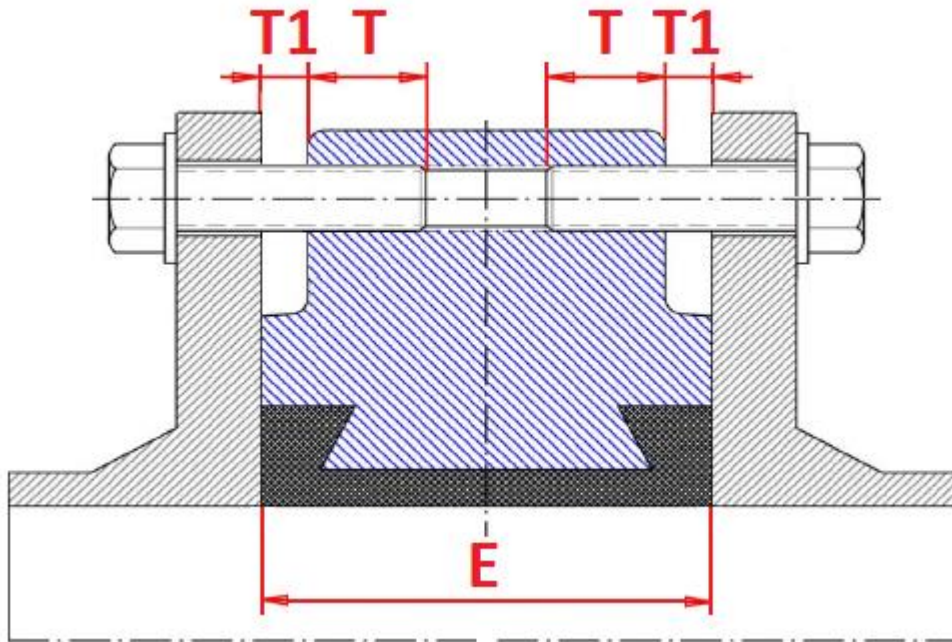

DN	PN10	PN16	Class 150 (PN20)	PN10, PN16 and CLASS 150	
	T	T	T	T1	E
32	13.5	13.5	13.6	2.5	33
40	13.5	13.5	12	2.5	33
50	14.5	14.5	13.5	2.5	43
65	13.5	13.5	14.3	3.5	46
80	16	16	17.2	4	46
100	17.5	17.5	18.7	2.5	52
125	20	20	23.2	3	56
150	20	20	21.6	3	56
200	23	23	23.4	3	60
250	26.5	26.5	27.3	2.5	68
300	31	29	30.3	3	78
350	37	33	33.1	2	78
400	41.5	35.5	41	2.5	102
450	37.5	41.5	45.8	4.5	114
500	38.5	47.5	43.6	3.5	127
600	38	50	38.4	4	154

**LUG BUTTERFLY VALVE EXCELLENCE RANGE**

**NECK AND DISC SIZE ( in mm ) :**

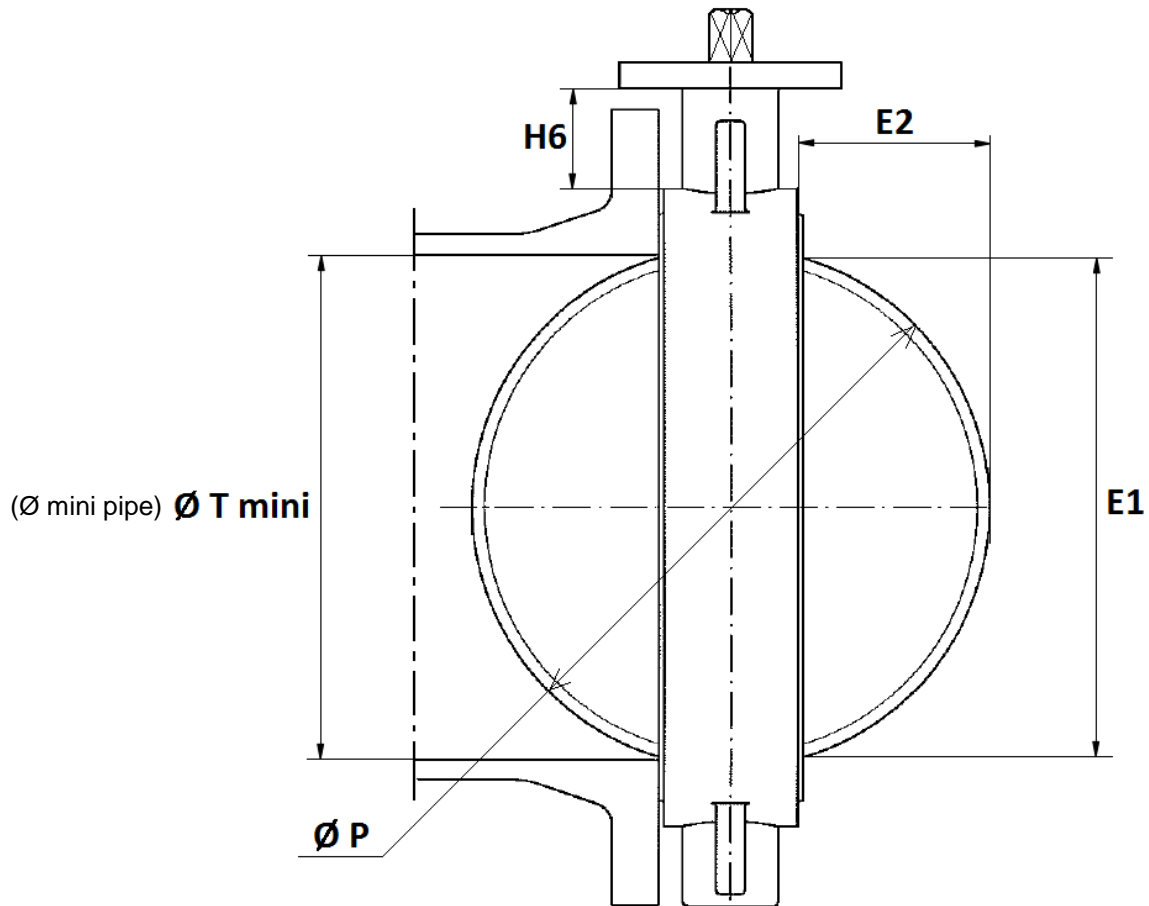

DN	32/40	50	65	80	100	125	150	200	250	300	350	400	450	500	600
E1	23	24.5	46	65	85	109	136	188	238	289	331	385	424	479	575
E2	3.5	3.5	9.5	17	24	33.5	45.5	69	90	110.5	131	148	162.5	184	221
H6	76	82	80	80	88	93	89	99	71	76	69	80	96	119	127
Ø T mini	26	27.5	49	68	88	112	139	191	241	292	334	388	427	482	578
Ø P	40	50	65	80	100	123	147	198	248	299	340	398	439	495	596

DN	700	750	800	900	1000	1100	1200	1300	1400
E1	680	721	777	850	957	1052	1146	1261	1368
E2	267.5	278	305	335.5	382.5	429	460	475.5	527.5
H6	148	140	170	150	162	175	176	240	228
Ø T mini	683	724	780	853	960	1055	1149	1264	1371
Ø P	700	746	800	874	981	1074	1174	1311	1415

**LUG BUTTERFLY VALVE EXCELLENCE RANGE**

**SIZE ( in mm ) :**

- **Square lever for special key ( 30x30 mm ) :**

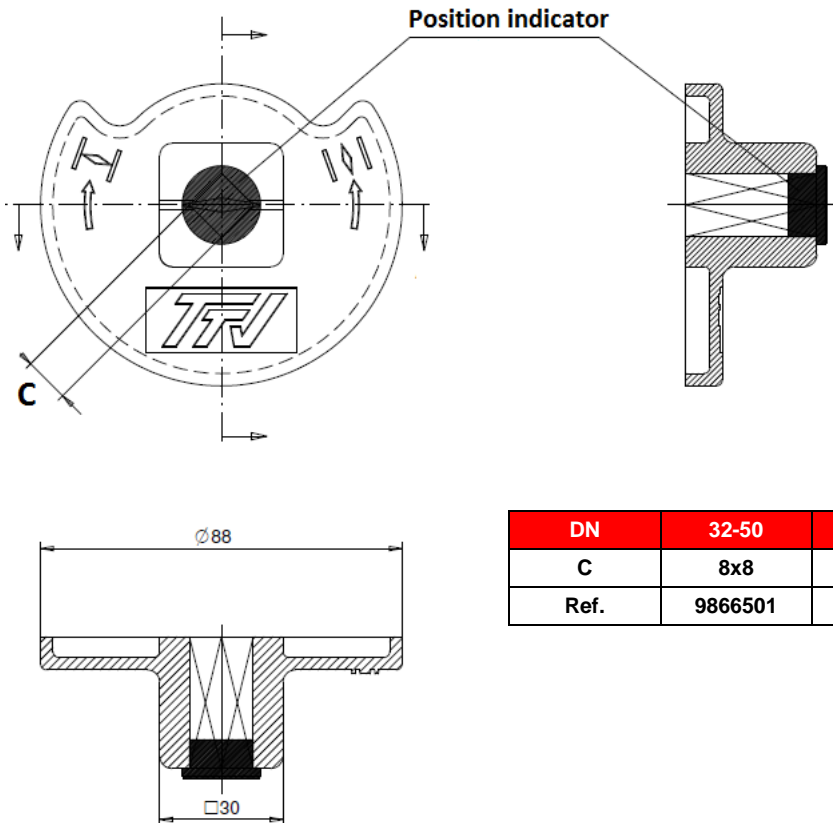

DN	32-50	65	80-100	125-150	200
C	8x8	9x9	11x11	14x14	17x17
Ref.	9866501	9866502	9866503	9866504	9866505



## LUG BUTTERFLY VALVE EXCELLENCE RANGE

### STANDARDS :

- Fabrication according to ISO 9001:2015
- Designing according to ISO 10631 and EN 593
- DIRECTIVE 2014/68/EU : CE N° 0038  
Risk Category III module H
- Certificate 3.1 on request
- Pressure tests according to EN 12266-1, Rate A
- Between flanges according to EN 1092-1 PN10/16
- ISO 5211 mounting pad
- Length according to ISO 5752 short series 20, EN 558 series 20 ( NF 29305 ),BS 5155 Wafer short/medium, DIN 3202 part 3, series K1
- ATEX Group II Category 2 G/2D Zone 1 & 21 Zone 2 & 22 ( optional marking )
- French water agreement **A.C.S. N° 19 ACC LY 080**
- Approval certificate **Marine BUREAU VERITAS**, N° 14087/C0 BV from DN32 to 1000

**ADVICE :** Our opinion and our advice are not guaranteed and SFERACO shall not be liable for the consequences of damages.  
The customer must check the right choice of the products with the real service conditions.



## LUG BUTTERFLY VALVE EXCELLENCE RANGE

### INSTALLATION INSTRUCTIONS

#### GENERAL GUIDELINES :

- Ensure that the valves to be used are appropriate for the conditions of the installation (type of fluid, pressure and temperature).
- Be sure to have enough valves to be able to isolate the sections of piping as well as the appropriate equipment for maintenance and repair.
- Ensure that the valves to be installed are of correct strength to be able to support the capacity of their usage.
- **Installation of all circuits should ensure that their function can be automatically tested on a regular basis (at least two times a year).**

#### INSTALLATION INSTRUCTIONS :

- **Before installing the valves, clean and remove any objects from the pipes** (in particular bits of sealing and metal) which could obstruct and block the valves.
- **Ensure that both connecting pipes either side of the valve (upstream and downstream) are aligned (if they're not, the valves may not work correctly).**
- **Make sure that the two sections of the pipe (upstream and downstream) match, the valve unit will not absorb any gaps. Any distortions in the pipes may affect the tightness of the connection, the working of the valve and can even cause a rupture. To be sure, place the kit in position to ensure the assembling will work.**
- **If sections of piping do not have their final support in place, they should be temporarily fixed. This is to avoid unnecessary strain on the valve.**
- The valve must be inserted between flanges with disc half opened but the disc must not overpass the valve thickness. Position the bolts to keep centered the valve. Then open fully the valve and tighten the bolts. **See graph under.**

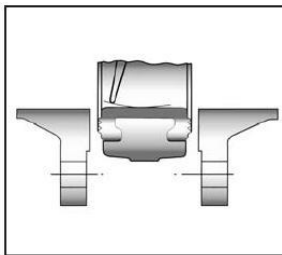

Half open valve introduction

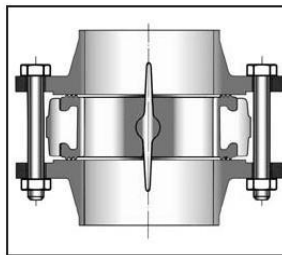

Complete opened disc valves  
when screw tightening

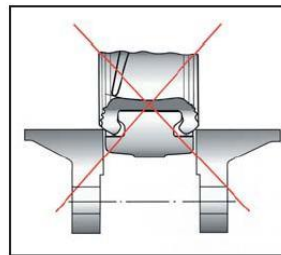

- Tighten the bolts in cross.
- The disc must move easily inside the pipe.
- Valves must be opened during cleaning operation.
- Tests must be done with a cleaned pipe.
- Tests must be done with opened valve. Test pressure must not be higher than the valve specification according to EN 12266-1.
- Then open slowly the valve.
- **Do not mount butterfly valves with stainless steel pressed collars and turning flanges without strias.**
- **And not on flat face flanges without strias ( example : painted cast iron fittings )**

## LUG BUTTERFLY VALVE EXCELLENCE RANGE

### MAXIMUM TIGHTENING TORQUES FOR BOLTING FLANGES :

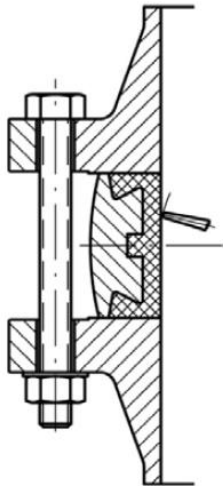

		Maximum torques (Nm)			
		Bolting types	5,6 / A307 Gr.B	8,8 / A193 B7	10,9
Bolting DN	M12 (1/2")	41,16	84,28	117,6	142,1
	M14 (9/16")	66,64	132,3	186,2	225,4
	M16 (5/8")	102,9	205,8	289,1	347,9
	M18 (3/4")	142,1	284,2	396,9	475,3
	M20 (3/4")	196	401,8	568,4	676,2
	M22 (7/8")	259,7	539	764,4	911,4
	M24 (1")	338,1	695,8	980	1176
	M27 (1"1/8)	499,8	1029	1470	1764
	M30 (1"1/4)	666,4	1421	1960	2352

### BEST POSITION INSTALLATION :

For wastewater, fluids with solid particles or cold network (air conditioning for example), the best position is the horizontal one :



- For an installation in ATEX area, check the conductivity between the valve, the upstream pipe and the downstream pipe and make sure the pipe is connected to the earth.

### MAINTENANCE :

- We recommend to operate fully the valve 1 to 2 times per year.
- During maintenance operation, ensure that the pipe isn't under pressure, that there's no fluid in the pipe and that the valve is isolated. If there's a fluid in the pipe, evacuate it. Ensure that there are no risks due to the temperature or the fluid (like acids). If the fluid is corrosive, inert the installation before maintenance operation.