

EXPANSION JOINT NBR PN10/16 130 mm LONG

ISO 9001

BUREAU VERITAS
Certification



Size : DN 32 to 200
Ends : Flanges PN10/16
Min Temperature : - 10°C
Max Temperature : + 80°C
Max Pressure : 16 Bars
Specifications : Absorb vibrations and noises
Linear and angular compansion
Single NBR sphere

Materials : Electro galvanized steel flanges

EXPANSION JOINT NBR PN10/16 130 mm LONG

SPECIFICATIONS :

- Absorb vibration, noises and expansion
- Linear and angular compansion
- Single sphere NBR
- Electro galvanized steel flanges PN10/16 up to DN150, PN10 over

USE :

- Oil, hydrocarbon, air
- Min and max Temperature Ts : - 10°C to + 80°C
- Max Pressure Ps : 16 bars

PRESSURE / TEMPERATURE GRAPH (STEAM EXCLUDED) :

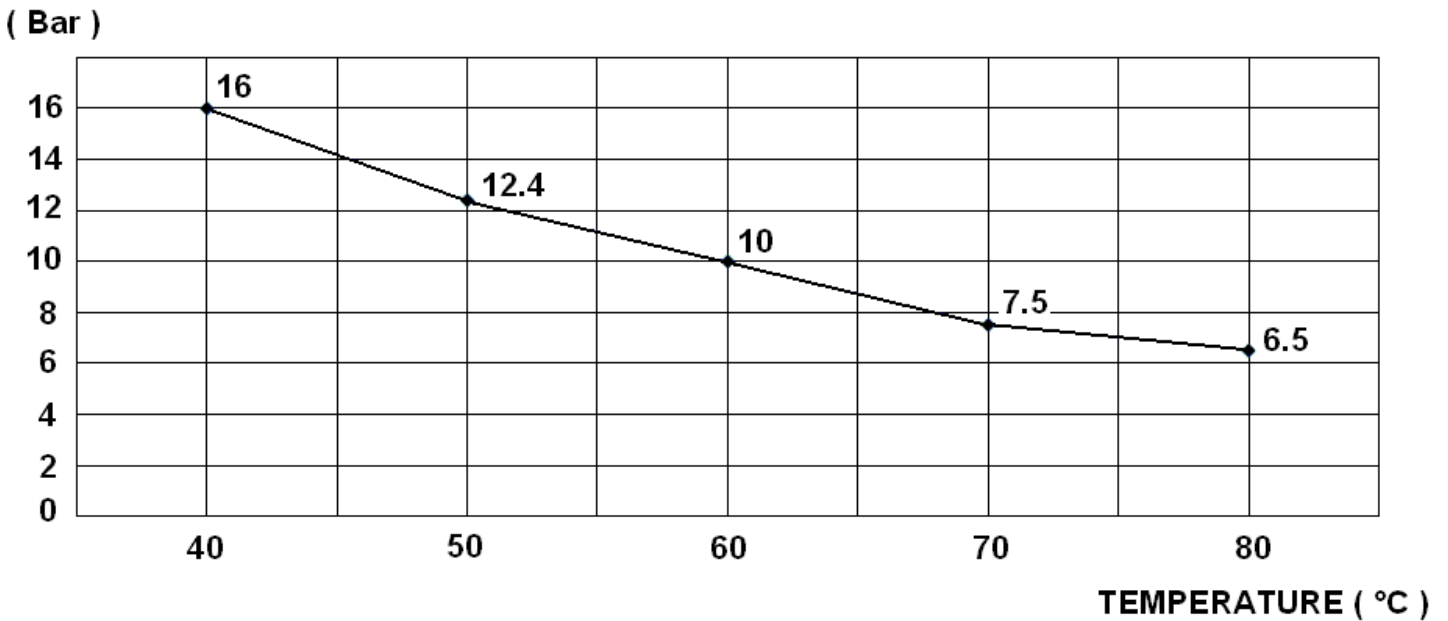

RANGE :

- NBR expansion joint 130 mm long with steel flanges PN10/16 from DN 32 to DN 150 and PN10 over, **Ref. 1506**
- Expansion limiter (with 2 studs and 4 plates included) PN10 from DN 32 to DN 300 **Ref. 9860607 to 9860617**

EXPANSION JOINT NBR PN10/16 130 mm LONG

MATERIALS :

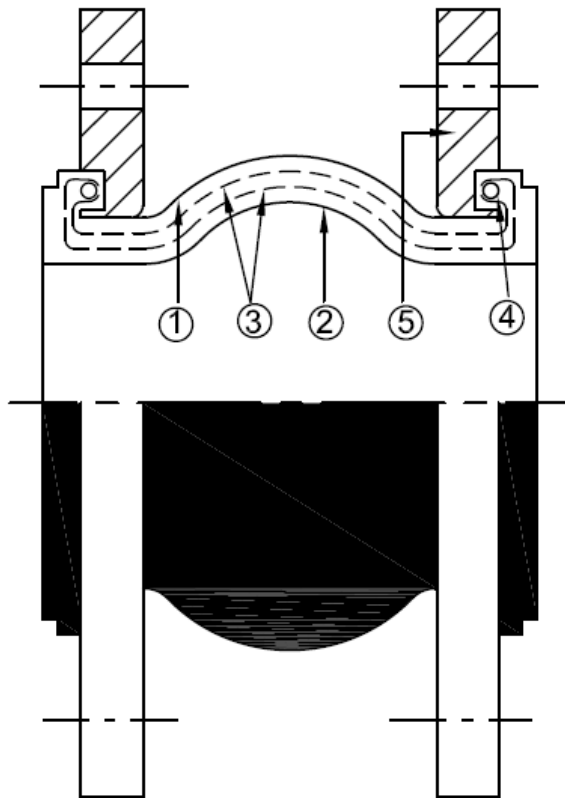

Item	Designation	Materials
1	Cover	EPDM
2	Inner tube	NBR
3	Reinforcement	Nylon cord
4	Brace	Hard steel
5	Flanges	Electro galvanized steel

EXPANSION JOINT NBR PN10/16 130 mm LONG

SIZE (in mm) :

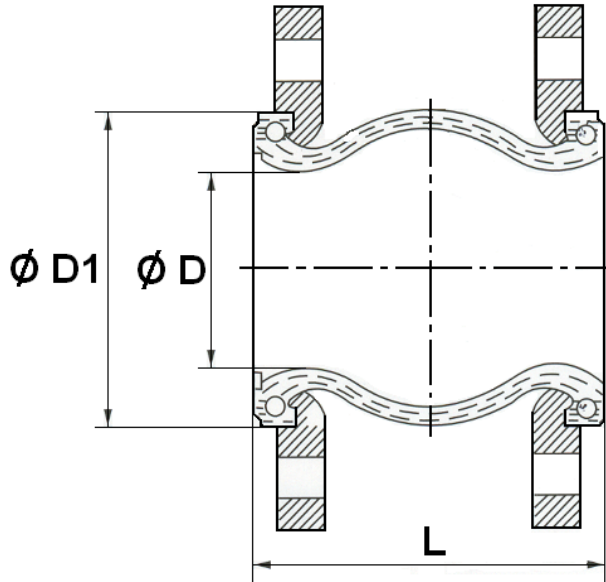

Ref.	DN	32	40	50	65	80	100	125	150	200
1506	L	130	130	130	130	130	130	130	130	130
	Ø D	29	36	48	63	72	92	123	144	199
	Ø D1	69	78	89	108	123	145	180	209	259
	Weight (Kg)	2.85	3.2	4.2	4.95	6	6.85	9.3	11.25	15.7

FLANGES SIZE (in mm) :

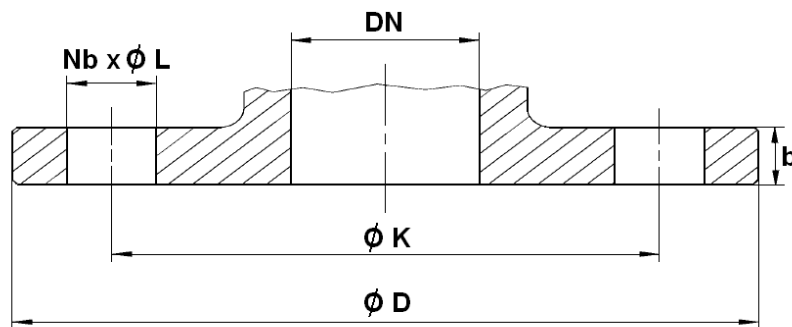

DN	32	40	50	65	80	100	125	150	200
Ø D	140	150	165	185	200	220	250	285	340
Ø K	100	110	125	145	160	180	210	240	295
Nb x Ø L	4 x 19	4 x 19	4 x 19	4 x 19	8 x 19	8 x 19	8 x 19	8 x 23	8 x 23
b	14	14	15	15	17	17	19	19	20

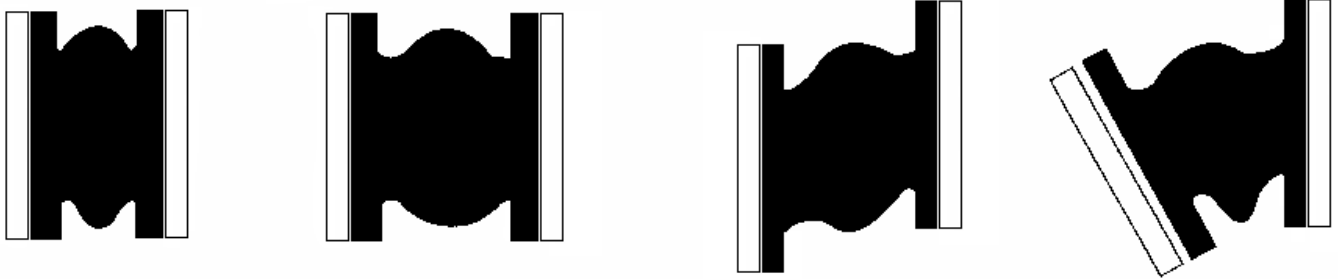
EXPANSION JOINT NBR PN10/16 130 mm LONG
MOVEMENTS (in mm) :

Compansion
Expansion
Lateral
Angular

DN	32	40	50	65	80	100	125	150	200
Compansion	8	8	8	12	12	12	16	16	20
Expansion	4	4	4	6	6	10	10	10	14
Lateral	8	8	8	10	10	12	12	12	18
Angular	15°	15°	15°	15°	15°	15°	15°	15°	15°

STANDARDS :

- Fabrication according to ISO 9001 : 2015
- DIRECTIVE 2014/68/EU : Products excluded from directive (Article 4, § 3)
- Flanges according to EN 1092-1 PN10/16

ADVICE : Our opinion and our advice are not guaranteed and SFERACO shall not be liable for the consequences of damages. The customer must check the right choice of the products with the real service conditions.

EXPANSION JOINT NBR PN10/16 130 mm LONG
INSTALLATION INSTRUCTION :

Expansion joint are designed for the absorption of previously specified movements under specific pressure and temperature conditions. So that the maximum service life is achieved, the following items must be observed during installation.

- Prior to fitment of the compensator it must be ensured that :
 - The route of the pipeline is straight - The expansion tallies with that of the chosen compensator
 - The expansion tallies with that of The chosen compensator
 - The fixes points are dimensionned so that they can absorb the reaction forces and stiffness rate that arise during use.
 - The pipeline is limited by fixed points
 - The distance between compensator and bearing may be a maximum of 3 times the pipe diameter. Place only one compensator between 2 bearings.
- Each pipe elbow must be fixed by support, specially if compensator is mounted with limiters. Fixed bearings are necessary because compensator is submitted to expansion when it is under pressure.
- Expansion joint must not be painted and heat-insulated. It must be protected from bad weather and solar radiation.
- During assembly operation, make sure screws are oriented according to the graph out below :

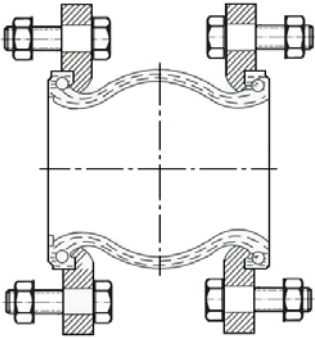

- Please apply the following stages order :
 - a) Fixed points for above pipeline
 - b) Fixed points for down pipeline
 - c) Compensator mounting
- Installation layout :

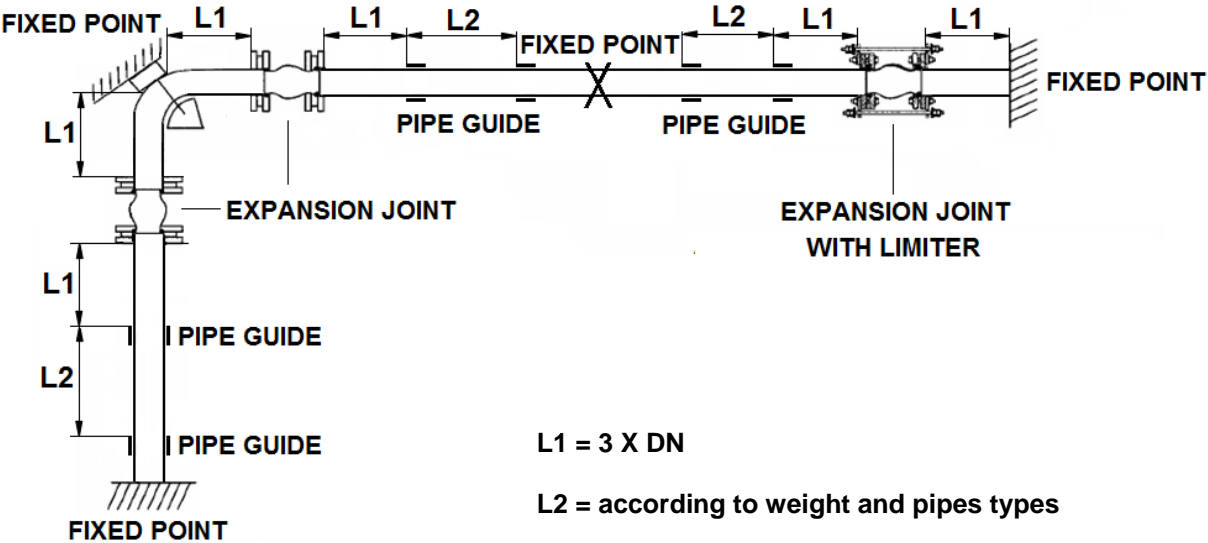

EXPANSION JOINT NBR PN10/16 130 mm LONG

INSTALLATION INSTRUCTION (SUITE) :

- Check that the compensator is not subjected to the weight of the pipeline. The installation length must agree with the installation gap. The compensator must never be twisted. It is recommended that specific characteristics be observed during maintenance :
 - The compensator must never be painted or recovered by heat insulation
 - The tightness of the bolts must be checked often.
 - The flanges must be perfectly cleared

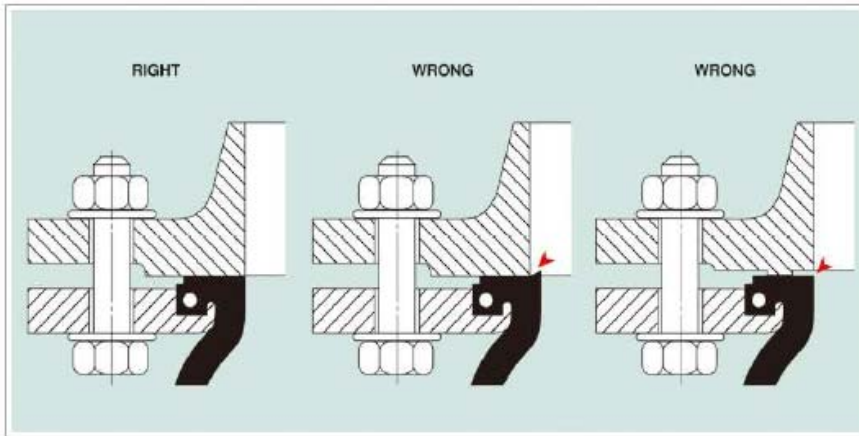

- Use limiters : When the working pressure can exceed the following values :
 - Up to DN100 : 10 bars
 - From DN125 to DN250 : 9 bars
 - From DN300 to DN350 : 6 bars
 - From DN400 to DN600 : 3 bars
 - When there is some risk of high pressure (pump starting) or high temperature.

The control rod assemblies are pre-set at the maximum Allowable expansion and/or contraction of the joint during The commissioning or operating. It is strictly recommended For unanchored / unsupported system and also spring Mounted pumps or equipments.

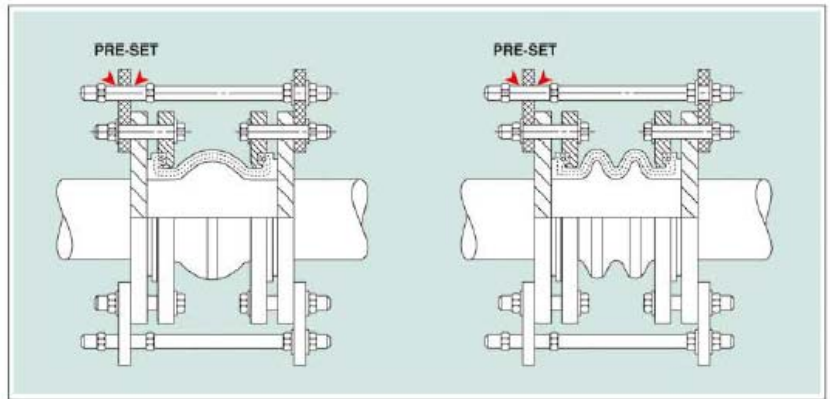

NOTA : The life of compensator can vary because of working conditions (fluids, pressure, temperature), that is why it is necessary to check it regularly.

WRONG INSTALLATION :

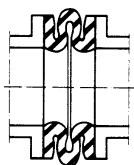

Excessive expansion

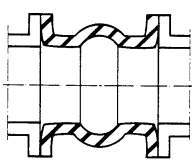

Excessive contraction

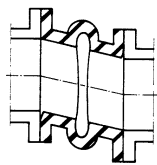

Cutting too important

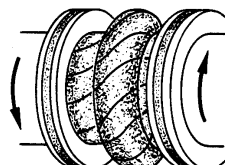

Torsion

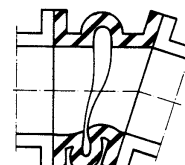

Important expansion and angular deviation

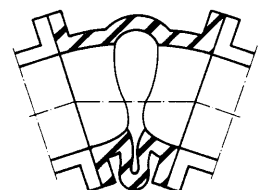

Angular deviation too important