

Flush tank valves



Introduction

The Habonim Flush Tank series incorporates all the advantages of the 3-piece ball valve 47 series and the TuBore™ 48 series. The innovation of the Flush Tank valve is the geometric design of the pad, which becomes an integral welded part of the customer's tank surface, allowing a smooth flow and preventing media stagnation. The result is a perfect adaptor between reactor and valve body.

The pad is designed for easy installation. It minimizes the diameter of the prepared tank bore, reduces installation time and welding operations and, most importantly, minimizes the stress concentration and tank deformation due to weld over-heating. The Habonim standard flush tank pad fits most tank configurations such as dished, flat, ellipsoidal, jacketed, conical or spherical. For special applications, such as replacing a conventional flush tank valve with a direct flow, higher Cv, quarter-turn flush tank ball valve, Habonim manufactures adaptive plates.

Habonim can also ship the pad independently from the valve, in order to accommodate customer requirements to simplify the vessel construction process.

Technical summary

Size range	½" - 4" (DN15 - DN100)
Series in range	R47 Series - standard and full port R48 Series - tube port
Pressure range	Vacuum 10 ⁻⁶ Tor up to 50 bar (700 psi)
Temperature range	-60 °C to +260 °C (-76 °F to +500 °F)
Materials	Stainless steel A351 CF8M/CF3M, A479 316/316L, carbon steel A216 WCB/A105,A350 LF2, alloy C22, alloy C276, duplex, super duplex, 254SMO, inconel 625, monel 400, titanium and more
Downstream end connection	Threaded, welded, flanged
Operation	Lever or gear operated, pneumatic or electric actuated
Service	Chemical, biopharma, cosmetics, food & beverage

Standards of compliance

Factory certification	ISO 9001-2015	Quality management system
Valve design and tests	ASME B16.34 :2013 API 6D / ISO14313 :2007 ISO17292 :2004 ANSI B1.20.1 :2013 EN 10226-1 :2004, ISO 7-1 :2007, JIS B0203 :1999 DIN3852 :2014 ANSI B16.11:2016, EN 12760:2016 ASME B16.25-2017, EN12627:1999 ASME B16.5:2017, EN 1092 -1:1997 ASME B16.10:2017, EN 558:2017 NACE MR-0175 :2015/ISO 15156 -1 :2015 NACE MR0103/ISO 17945 :2015 EN 12266-1 :2012, API 598 :2016 ISO 15848-1 :2015	Valve design NPT - National Pipe Taper thread BSPT - British Standard Pipe Taper thread BSPP Socket weld end connection Buttweld end connection (Schedule 5, 10, 40, 80) Flange dimensions Face-to-Face dimensions Materials for use in H ₂ S-containing environments in oil and gas production Metallic materials resistant to sulfide stress cracking in corrosive petroleum refining environments Testing of metallic valves - Pressure tests, test procedures and acceptance criteria Industrial valves - measurement, test and qualification procedures for fugitive emissions Pressure equipment directive equipment and protective systems intended for use in potentially explosive atmospheres (optional for actuated unit only) Safety integrity level - Functional safety of electrical/electronic/programmable electronic safety-related systems (optional for actuated unit only)
Certifications	PED 2014/68/EU Module H ATEX 2014/34/EU IEC 61508-2/3 :2010 SIL2/3	
Documentation	EN 10204 :2004 2.2/3.1/3.2	Metallic materials - types of inspection documents

Design features

Pad design

- Mirror polished
- Various geometries: dished, flat, ellipsoidal, Jacketed, conical or spherical
- Flush Pipe (FP) – Adaptive pad with the same geometry of the pipe line, designed to provide minimum 'dead volume' in pipe lines, preventing media from stagnating and fully insuring drainage of pipe cavities.

Body

- Minimum dead leg between ball sphere and tank internal surface
- Three-piece design with swing-out body, for easy maintenance
- Top mounting platform compliant with ISO 5211 for easy mounting of actuator and other accessories
- CIP/SIP purge ports ensure complete flush of the valve cavity (optional)
- Steam jacket (optional)
- Streamlined flow ensures full drainage

Ball

- Mirror polished solid ball
- Bidirectional as standard
- High flow capacity with low pressure drop at full opening
- Floating ball concept for positive shutoff
- Variety of materials and designs

Stem

- One-piece solid stem
- Blowout-proof design
- Antistatic device

Mirror polished pad

Minimum dead leg

Variety of seat materials

HermetiX™ stem seal

Mirror polished solid ball

No restrictions ensure full drainage

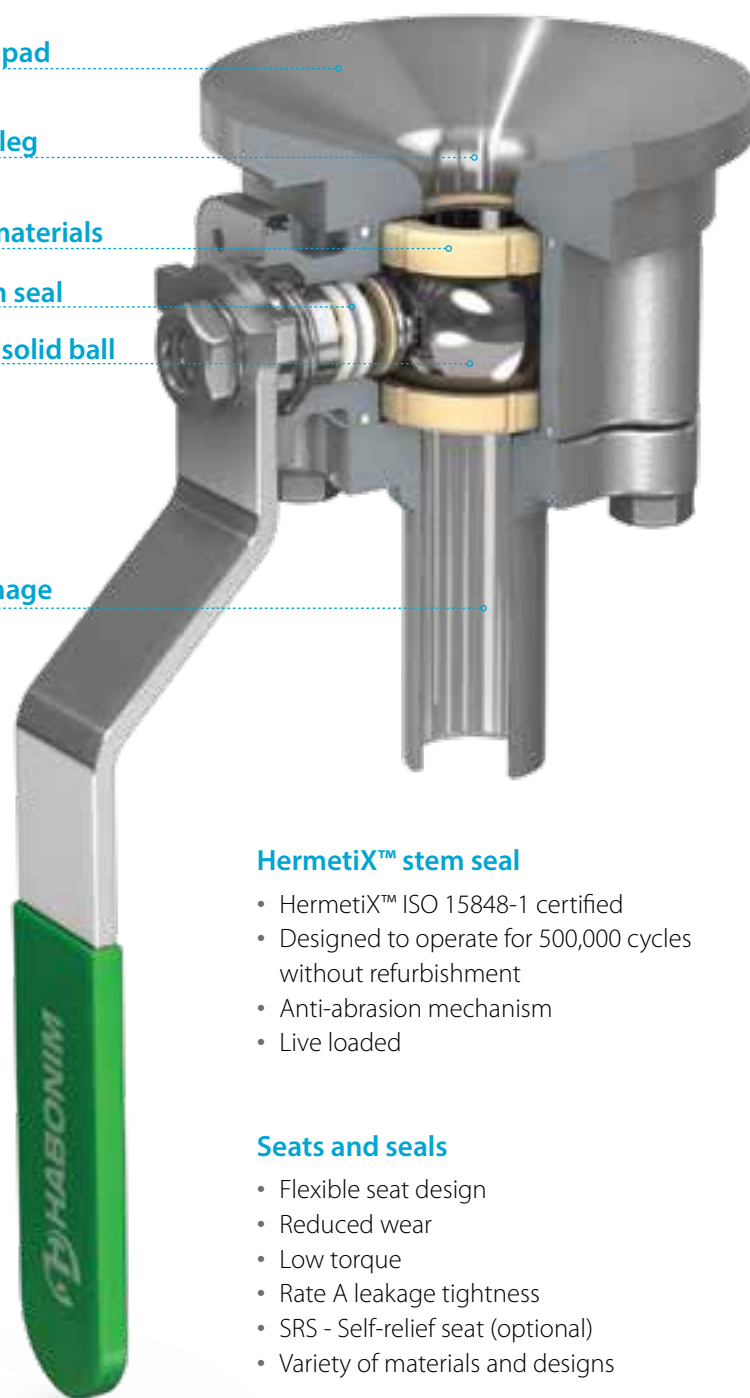

HermetiX™ stem seal

- HermetiX™ ISO 15848-1 certified
- Designed to operate for 500,000 cycles without refurbishment
- Anti-abrasion mechanism
- Live loaded

Seats and seals

- Flexible seat design
- Reduced wear
- Low torque
- Rate A leakage tightness
- SRS - Self-relief seat (optional)
- Variety of materials and designs

Handle

- Rigid handle indicating flow direction
- Easy valve operation
- Various designs
- Locking devices (optional)

Floating Ball Valves

Flush tank valves

General

3 Piece standard

3 Piece TuBore™

Ordering code system

Size ½"- 2½" | DN15-DN65 | Class 300 | R47X/R47P⁽¹⁾ Series

Valve dimensions

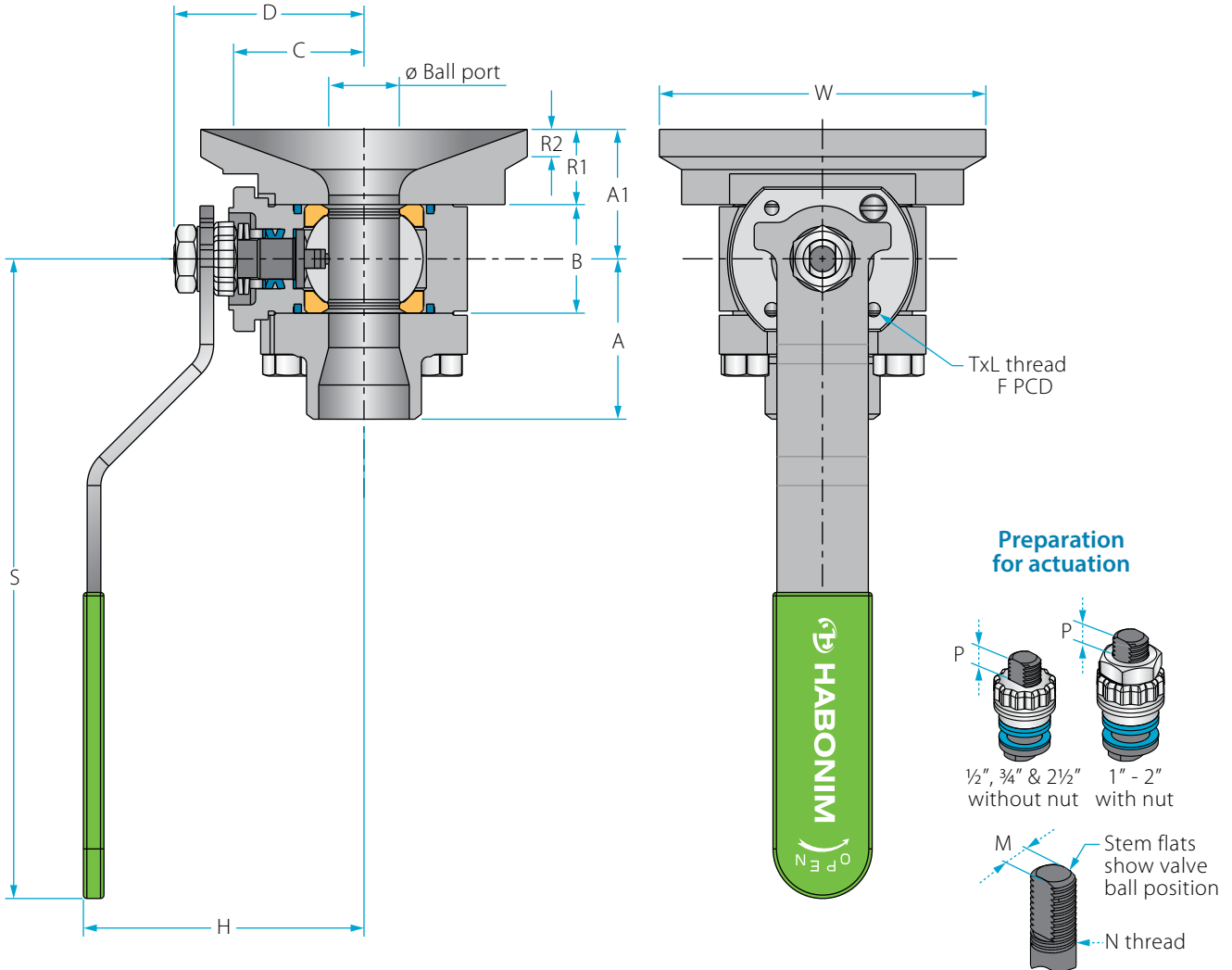

Std. port	Full port	Unit	Ball port	R1	R2	A	A1	B	C	D	H	S	W	M	N	P	F	TxL	Weight kg/lb	Kv Cv
DN15	DN10	mm	11.15	21.00	6.00	33.00	31.30	20.60	29.00	38.70	61.50	150.00	60.00	16.00	⅜	6.65 (F03)	36.00	M5X10	0.8	6.9
½"	⅜"	inch	0.44	0.83	0.24	1.30	1.24	0.81	1.14	1.52	2.42	5.91	2.36	0.63	UNF	0.26	1.42		1.9	8.0
DN20	DN15	mm	14.30	20.60	6.00	35.30	32.85	24.50	31.40	40.30	63.90	150.00	80.00	5.54	⅜	6.65 (F03)	36.00	M5X10	1.2	10
¾"	½"	inch	0.56	0.81	0.24	1.39	1.29	0.97	1.24	1.59	2.52	5.91	3.15	0.22	UNF	0.26	1.42		2.6	12
DN25	DN20	mm	20.60	21.50	8.00	46.90	37.35	31.70	38.20	55.60	79.40	187.00	95.50	7.54	7/16	7.40 (F04)	42.00	M5X10	2.1	28
1"	¾"	inch	0.81	0.85	0.31	1.85	1.47	1.25	1.50	2.19	3.13	7.36	3.76	0.30	UNF	0.29	1.65		4.6	32
DN32	DN25	mm	25.50	24.00	8.00	54.00	45.00	41.25	195.40	212.90	236.40	230.00	69.00	7.54	7/16	7.40 (F04)	42.00	M5X10	3.2	49
1¼"	1"	inch	1.00	0.94	0.31	2.13	1.77	1.62	7.69	8.38	9.31	9.06	2.72	0.30	UNF	0.29	1.65		7.0	57
DN40	DN32	mm	31.80	27.00	8.00	57.80	51.20	48.40	43.60	73.00	97.00	237.00	113.00	8.71	9/16	8.50 (F05)	50.00	M6X12	4.5	69
1½"	1"	inch	1.25	1.06	0.31	2.28	2.01	1.91	1.72	2.87	3.82	9.33	4.45	0.34	UNF	0.33	1.97		9.9	80
DN50	DN40	mm	38.10	29.00	10.00	64.00	57.15	56.30	48.30	77.80	101.80	237.00	138.00	8.71	9/16	8.50 (F05)	50.00	M6X12	5.8	102
2"	1½"	inch	1.50	1.14	0.39	2.52	2.25	2.22	1.90	3.06	4.01	9.33	5.43	0.34	UNF	0.33	1.97		12.8	118
DN65	DN50	mm	50.80	30.00	10.00	79.00	66.30	72.60	70.00	88.10	115.10	237.00	164.00	8.71	9/16	13.50 (F07)	70.00	M8X12	11.1	208
2½"	2"	inch	2.00	1.18	0.39	3.11	2.61	2.86	2.76	3.47	4.53	9.33	6.46	0.34	UNF	0.53	2.76		24.4	241

Components & materials

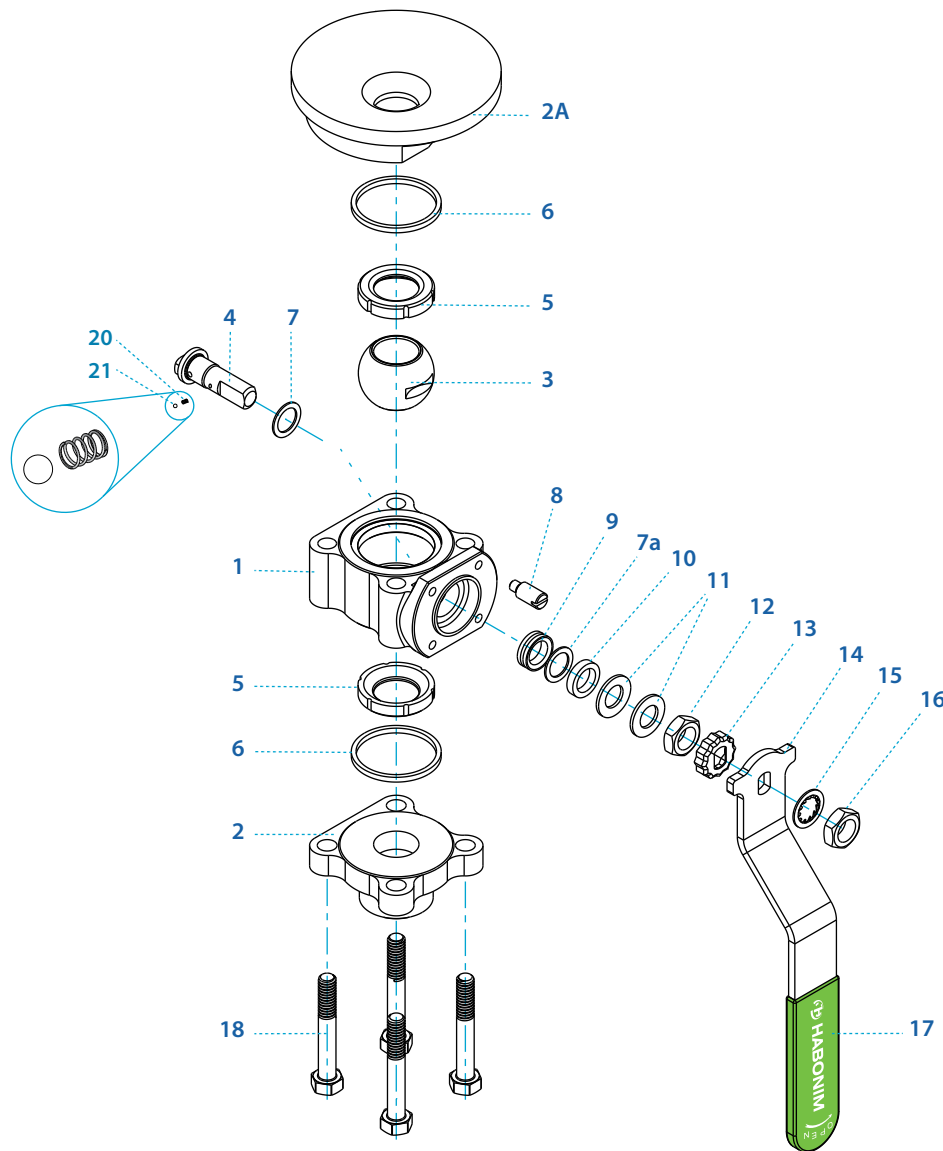

Item	Description	Material specification	Qty.
1	Body	A351 CF8M, A216 WCB, A105, A351 CN7M, A494 M35-1, A494 CW-12MW, A494 CX-2MW, A351 CK3MCuN, A995 CD3MN 4A, A995 CE3MN 5A	1
2	End	A351 CF3M, A216 WCB, A105, A351 CN7M, A494 M35-1, A494 CW-12MW, A494 CX-2MW, A351 CK3MCuN, A995 CD3MN 4A, A995 CE3MN 5A	1
2A	Pad	A479 316L, B473 N08020, B164 N04400, B574 N06022, B574 N10276, A479 S31254, A479 S31803, A479 S32750	1
3	Ball	A351 CF8M, B473 N08020, B164 N04400, B574 N06022, B574 N10276, A479 S31254, A479 S31803, A479 S32750	1
4	Stem	A479 316L, A564 Gr 630 H1150D 17-4PH, B473 N08020, B164 N04400, B574 N06022, B574 N10276, A479 S31254, A479 S31803, A479 S32750	1
5*	Seat	PTFE, RPTFE, CF PTFE, PEEK, CF PEEK, TFM, UHMWPE, VESPEL, PVDF, DELRIN, PCTFE (KEL-F)	2
6*	Body seal	PTFE, RPTFE, TFM, UHMWPE, Graphite	2
7*	Stem thrust seal	PEEK, CF PEEK, PCTFE (KEL-F), TFM ⁽²⁾ , CF PTFE ⁽²⁾	1

Item	Description	Material specification	Qty.
7a**	Anti-abrasion ring	PEEK, CF PEEK, PCTFE (KEL-F), TFM ⁽²⁾ , CF PTFE ⁽²⁾	1
8	Stop pin	A582 303	1
9*	Stem seal	CF PTFE, TFM, Graphite ⁽²⁾	1
10	Follower	B783 316L	1
11	Disc spring	A693 631 17-7PH	2
12	Stem nut	A194 8M, EN3506-2 A4-80	1
13	Locking clip	A167 304	1
14	Handle	A240 430	1
15	Serrated washer	A240 410	1
16	Handle nut	A194 8M, EN3506-2 A4-80	1
17	Sleeve	PVC	1
18	Bolt	C.St 8.8 ZP, A193 B8, EN3506-1 A2-70	4
20	Anti static spring	A313 302	1
21	Anti static plunger	A479 304	1
23	Tag (not shown)	A167 304	1

⁽¹⁾ R47P Series is Habonim's standard valve design without the HermetiX™ stem seal construction.

⁽²⁾ This material can only be used as part of the R47P design.

* Repair kit components
 ** Only with HermetiX™ stem seal

Floating Ball Valves

Flush tank valves

General

3 Piece standard

3 Piece TuBore™

Ordering code system

Size 3"- 4" | DN80-DN100 | Class 300 | R47X/R47P⁽¹⁾ Series

Valve dimensions

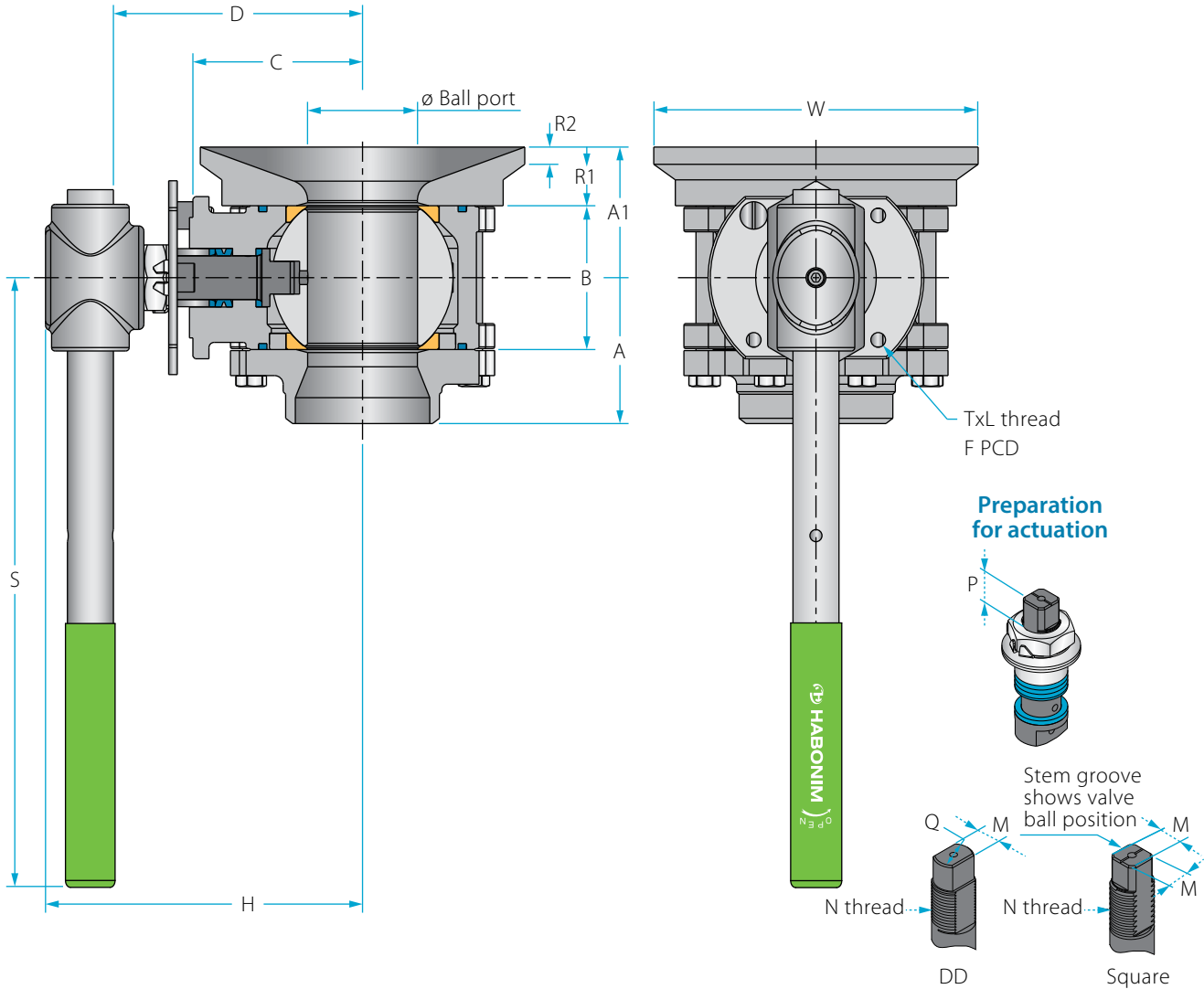

Std. port	Full port	Unit	Ball port	R1	R2	A	A1	B	C	D	H	S	W	M-DD	M	N	P	Q	F	TxL	Weight kg/lb	Kv	Cv
DN80	DN65	mm	63.50	34.00	10.00	84.50	75.65	83.30	98.30	144.90	185.00	400.00	188.00	15.90	18.90	1"-14	16.70	22.70 (F10)	102.00	M10x20	15.5	300	
3"	2½"	inch	2.50	1.34	0.39	3.33	2.98	3.28	3.87	5.71	7.29	15.75	7.40	0.63	0.74	UNS-2A	0.66	0.89	4.02		34.1	348	
DN100	DN80	mm	82.60	38.00	10.00	107.00	92.40	108.80	114.10	160.70	200.00	600.00	226.00	15.90	18.90	1"-14	16.70	22.70 (F10)	102.00	M10x20	26.0	615	
4"	3"	inch	3.25	1.50	0.39	4.21	3.64	4.28	4.49	6.33	7.89	23.62	6.97	0.63	0.74	UNS-2A	0.66	0.89	4.02		57.2	713	
	DN100	mm	100.00	45.00	12.00	119.50	106.50	123.00	124.00	170.50	211.00	600.00	252.00	15.90	18.90	1"-14	16.70	22.70 (F10)	102.00	M10x20	34.0	744	
	4" FB	inch	3.94	1.77	0.47	4.70	4.19	4.84	4.88	6.71	8.30	23.62	8.54	0.63	0.74	UNS-2A	0.66	0.89	4.02		74.8	863	

Components & materials

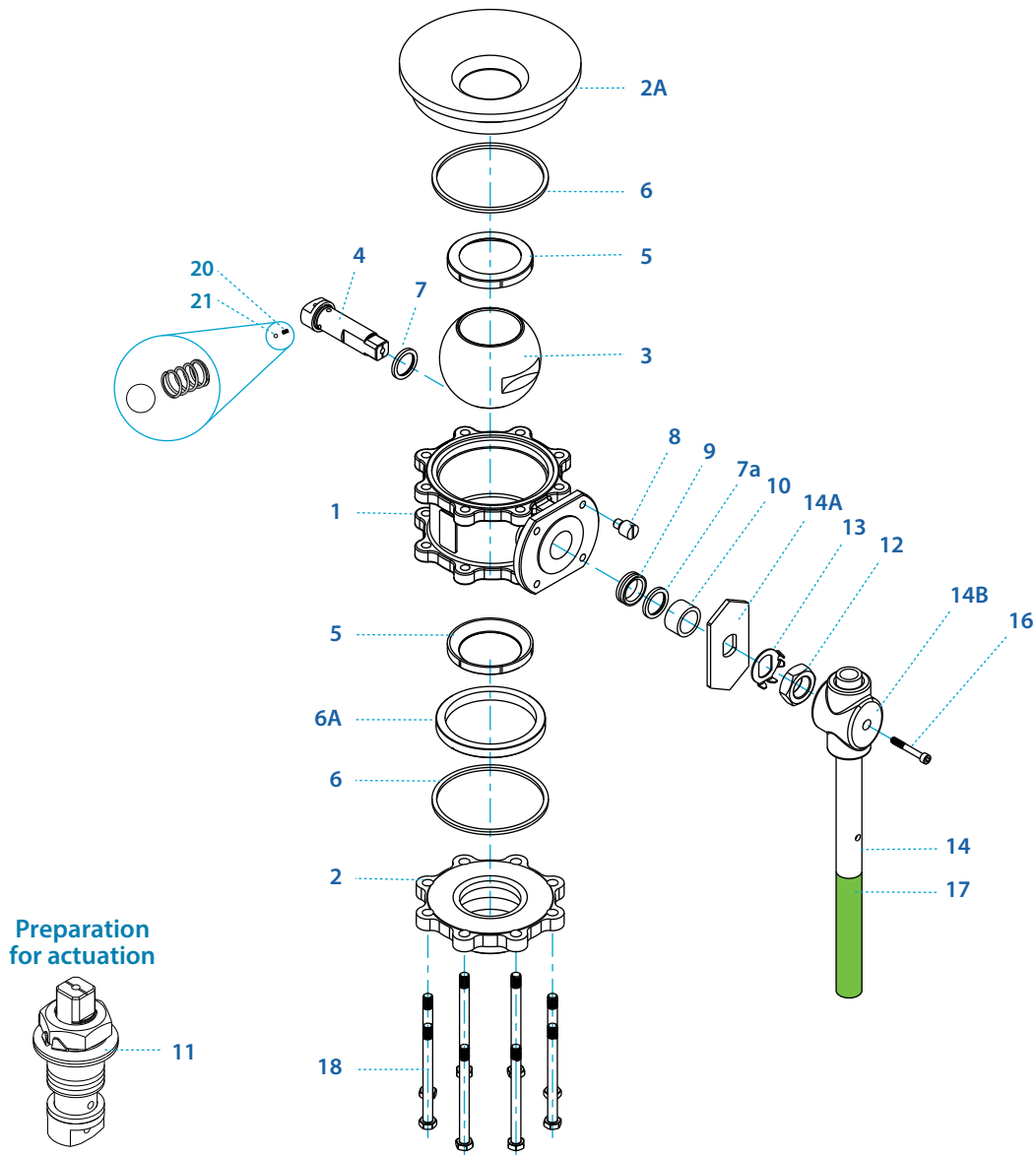

Item	Description	Material specification	Qty.
1	Body	A351 CF8M, A216 WCB, A105, A351 CN7M, A494 M35-1, A494 CW-12MW, A494 CX-2MW, A351 CK3MCuN, A995 CD3MN 4A, A995 CE3MN 5A	1
2	End	A351 CF3M, A216 WCB, A105, A351 CN7M, A494 M35-1, A494 CW-12MW, A494 CX-2MW, A351 CK3MCuN, A995 CD3MN 4A, A995 CE3MN 5A	1
2A	Pad	A479 316L, B473 N08020, B164 N04400, B574 N06022, B574 N10276, A479 S31254, A479 S31803, A479 S32750	1
3	Ball	A351 CF8M, B473 N08020, B164 N04400, B574 N06022, B574 N10276, A479 S31254, A479 S31803, A479 S32750	1
4	Stem	A479 316L, A564 Gr 630 H1150D 17-4PH, B473 N08020, B164 N04400, B574 N06022, B574 N10276, A479 S31254, A479 S31803, A479 S32750	1
5*	Seat	PTFE, RPTFE, CF PTFE, PEEK, TFM, UHMWPE, VESPEL, PVDF, DELRIN, PCTFE (KEL-F)	2
6*	Body seal	PTFE, RPTFE, TFM, UHMWPE, Graphite	2
6A	Support Ring	A479 316L, B473 N08020, B164 N04400, B574 N06022, B574 N10276, A479 S31254, A479 S31803, A479 S32750	1
7*	Stem thrust seal	PEEK, CF PEEK, PCTFE (KEL-F), TFM, CF PTFE	1

Item	Description	Material specification	Qty.
7a**	Anti-abrasion ring	PEEK, CF PEEK, PCTFE (KEL-F), TFM, CF PTFE	1
8	Stop pin	A582 303	1
9*	Stem seal	CF PTFE, TFM, Graphite	1
10	Follower	B783 316L	1
11	Disc spring	A693 631 17-7PH	2
12	Stem nut	C.St B18 ZP	1
13	Tab lock washer	A240 304	1
14	Wrench handle	A240 316L	1
14A	Stop plate	A240 430	1
14B	Wrench head	A351 CF8M	1
16	Wrench bolt	EN3506-1 A2-70/A4-80, A193 Gr B8/B8M	1
17	Sleeve	PVC	1
18	Body bolts	C.St 8.8 ZP, A193 B8, EN3506-1 A2-70	6-10
20	Anti static spring	A313 302	2
21	Anti static plunger	A479 304	2
23	Tag (not shown)	A167 304	1

* Repair kit components

** Only with HermetiX™ gland packing

⁽¹⁾ 47P Series is Habonim's standard valve design without the HermetiX™ stem seal construction.

⁽²⁾ This material can only be used as part of the 47P design.

Floating Ball Valves

Flush tank valves

General

3 Piece
standard

3 Piece
TuBore™

Ordering
code system

Size ½"- 2" | DN15-DN65 | Class 300 | R48X/R48⁽¹⁾ Series

Valve dimensions

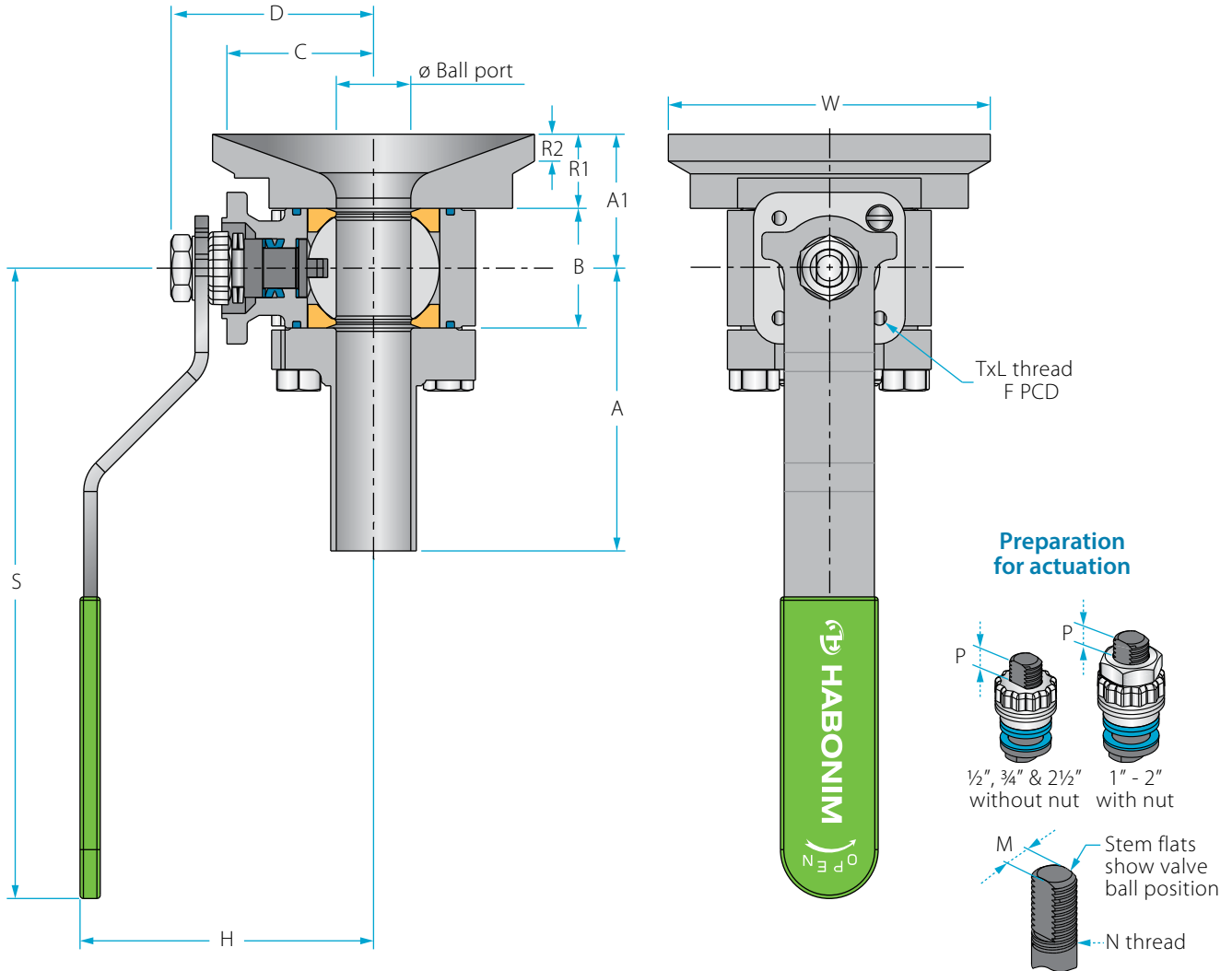

Std. port	Unit	OD	Ball port	R1	R2	A	A1	B	C	D	H	S	W	M	N	P	F	TxL	Weight kg/lb	Kv	Cv
DN15	mm	12.70	9.40	21.00	6.00	68.50	31.30	20.60	29.00	38.00	61.60	150.00	60.00	5.54	3/8	6.50 (F03)	36.00	M5X10	1.1	8	
½"	inch	0.50	0.37	0.83	0.24	2.70	1.23	0.81	1.14	1.50	2.42	5.91	2.36	0.22	UNF	0.26	1.42		2.4	9	
DN20	mm	19.03	15.75	20.60	6.00	73.50	32.80	24.60	36.00	45.00	67.90	150.00	80.00	5.54	3/8	7.10 (F03)	36.00	M5X10	1.3	29	
¾"	inch	0.75	0.62	0.81	0.24	2.89	1.29	0.97	1.42	1.77	2.67	5.91	3.15	0.22	UNF	0.28	1.42		2.9	34	
DN25	mm	25.40	22.10	22.00	8.00	84.00	39.80	35.50	43.50	61.00	84.80	187.00	95.50	7.54	7/16	9.20 (F04)	42.00	M5X10	2.2	53	
1"	inch	1.00	0.87	0.87	0.31	3.31	1.56	1.40	1.71	2.41	3.34	7.36	3.76	0.30	UNF	0.36	1.65		4.8	62	
DN32	mm	38.20	34.80	32.70	8.00	93.00	57.70	50.00	55.50	85.00	107.10	236.00	140.00	8.71	9/16	13.00 (F05)	50.00	M6X12	4.4	150	
1½"	inch	1.50	1.37	1.29	0.31	3.66	2.27	1.97	2.19	3.35	4.22	9.29	5.51	0.34	UNF	0.51	1.97		9.7	175	

Components & materials

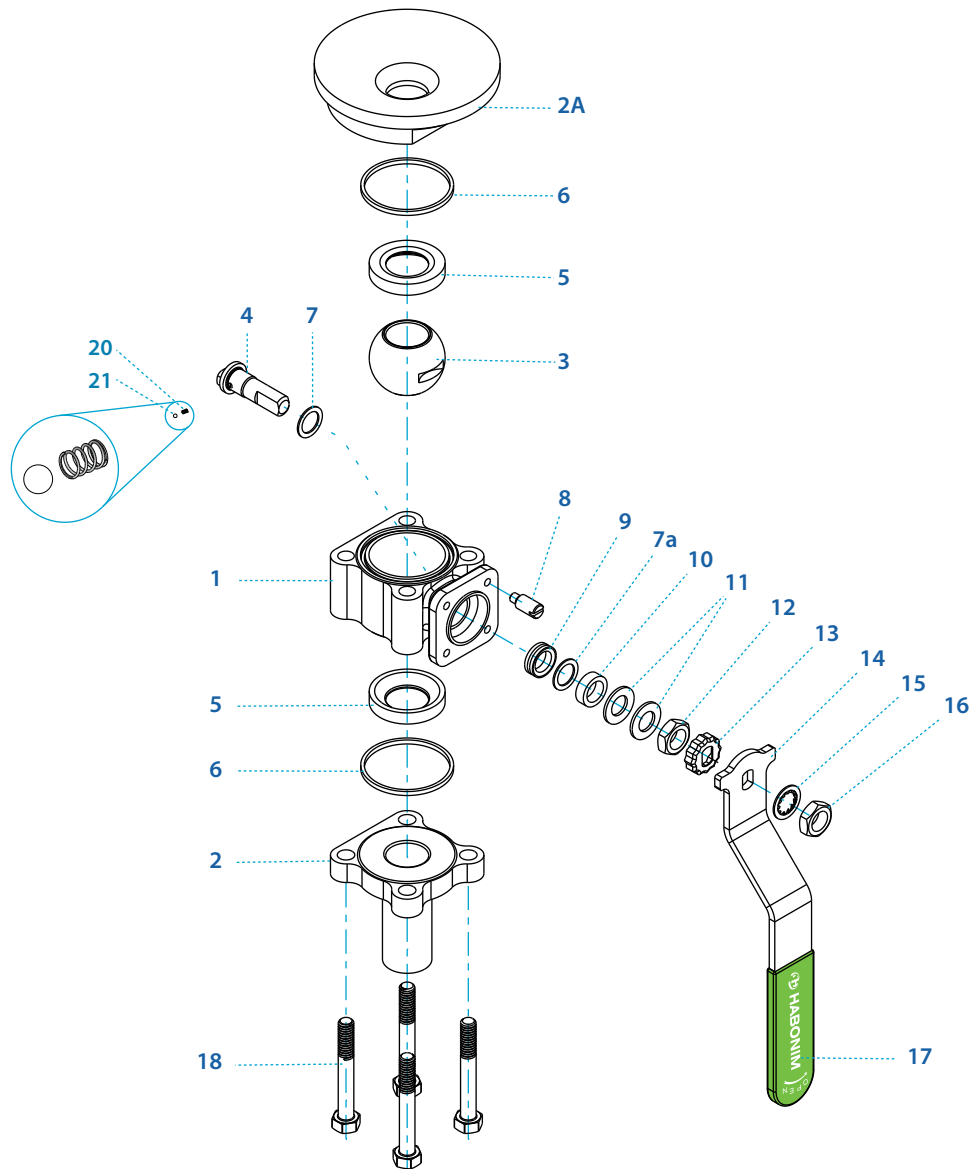

Item	Description	Material specification	Qty.
1	Body	A351 CF8M, A216 WCB, A105, A351 CN7M, A494 M35-1, A494 CW-12MW, A494 CX-2MW, A351 CK3MCuN, A995 CD3MN 4A, A995 CE3MN 5A	1
2	End	A351 CF3M, A216 WCB, A105, A351 CN7M, A494 M35-1, A494 CW-12MW, A494 CX-2MW, A351 CK3MCuN, A995 CD3MN 4A, A995 CE3MN 5A	1
2A	Pad	A479 316L, B473 N08020, B164 N04400, B574 N06022, B574 N10276, A479 S31254, A479 S31803, A479 S32750	1
3	Ball	A351 CF8M, B473 N08020, B164 N04400, B574 N06022, B574 N10276, A479 S31254, A479 S31803, A479 S32750	1
4	Stem	A479 316L, A564 Gr 630 H1150D 17-4PH, B473 N08020, B164 N04400, B574 N06022, B574 N10276, A479 S31254, A479 S31803, A479 S32750	1
5*	Seat	PTFE, RPTFE, CF PTFE, PEEK, CF PEEK, TFM, UHMWPE, VESPEL, PVDF, DELRIN, PCTFE (KEL-F)	2
6*	Body seal	PTFE, RPTFE, TFM, UHMWPE, Graphite	2
7*	Stem thrust seal	PEEK, CF PEEK, PCTFE (KEL-F), TFM ⁽²⁾ , CF PTFE	1

Item	Description	Material specification	Qty.
7a**	Anti-abrasion ring	PEEK, CF PEEK, PCTFE (KEL-F), TFM ⁽²⁾ , CF PTFE ⁽²⁾	1
8	Stop pin	A582 303	1
9*	Stem seal	CF PTFE, TFM, Graphite ⁽²⁾	1
10	Follower	B783 316L	1
11	Disc spring	A693 631 17-7PH	2
12	Stem nut	A194 8M, EN3506-2 A4-80	1
13	Locking clip	A167 304	1
14	Handle	A240 430	1
15	Serrated washer	A240 410	1
16	Handle nut	A194 8M, EN3506-2 A4-80	1
17	Sleeve	PVC	1
18	Bolt	C.St 8.8 ZP, A193 B8, EN3506-1 A2-70	4
20	Anti static spring	A313 302	1
21	Anti static plunger	A479 304	1
23	Tag (not shown)	A167 304	1

* Repair kit components
 ** Only with HermetiX™ stem seal

⁽¹⁾ R48 Series is Habonim's standard valve design without the HermetiX™ stem seal construction.

⁽²⁾ This material can only be used as part of the R48 design.

Floating Ball Valves

Flush tank valves

General

3 Piece
standard

3 Piece
TuBore™

Ordering
code system

Size 2½" - 4" | DN65-DN100 | Class 300 | R48X/R48⁽¹⁾ Series

Valve dimensions

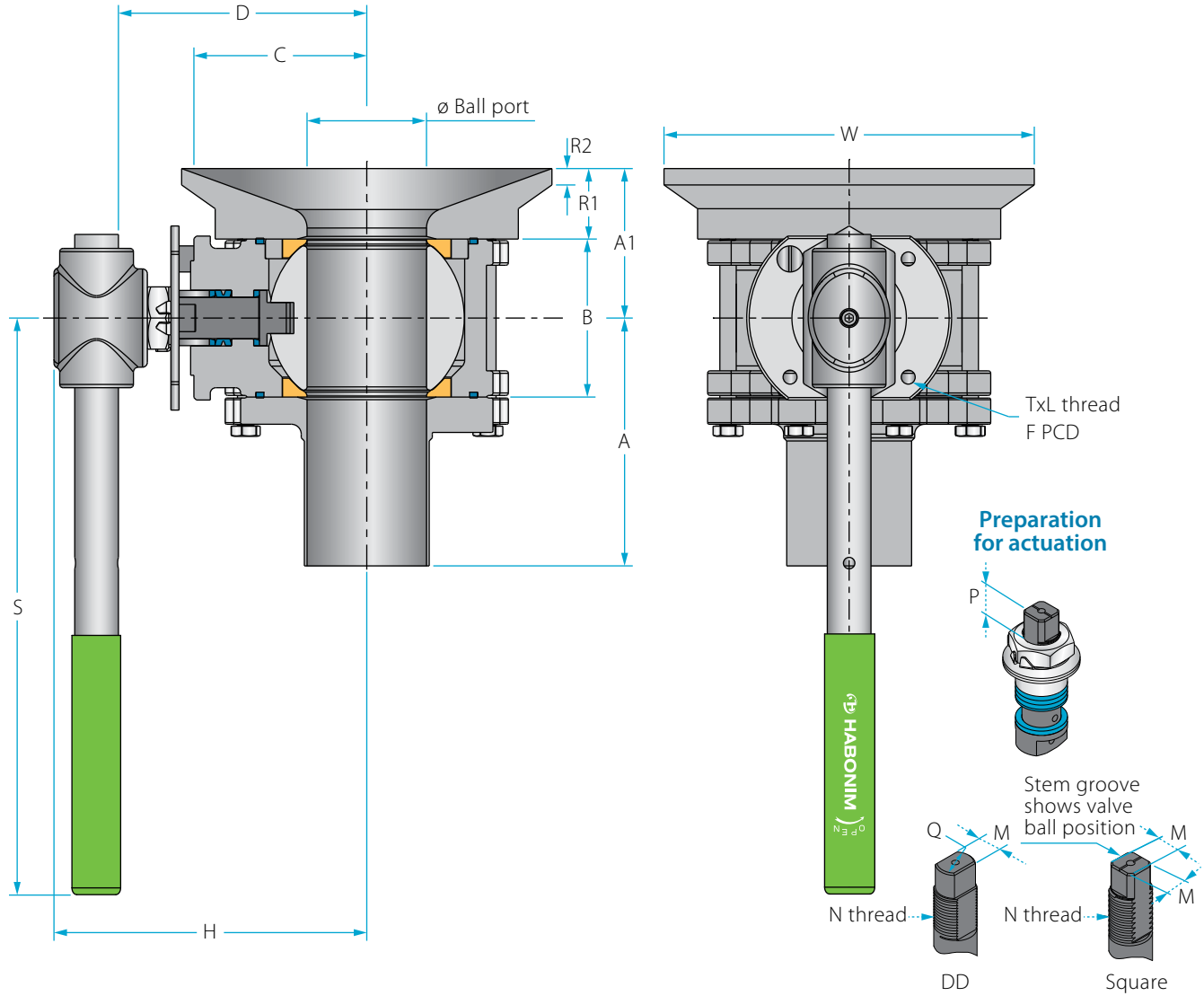

Std. port	Unit	Ball port	R1	R2	A	A1	B	C	D	H	S	W	M-DD	M	N	P	Q	F	TxL	Weight kg/lb	Kv Cv	
DN50	mm	50.80	30.00	10.00	112.00	66.30	72.60	70.00	111.60	137.50	400.00	108.00	13.90	-	M20x2.5	14.60	20.00	(F07)	70.00	M8x12	10.0	410
2"	inch	2.00	1.18	0.39	4.41	2.61	2.86	2.76	4.39	5.41	15.75	4.25	0.55	-		0.57	0.79		2.76	M8x12	22.0	480
DN80	mm	60.20	34.00	10.00	125.20	75.70	83.35	98.30	144.90	185.00	400.00	188.00	0.63	0.74	1"-14	16.70	22.70	(F10)	102.00	M10x20	15.0	581
2½"	inch	2.37	1.34	0.39	4.93	2.98	3.28	3.87	5.71	7.29	15.75	7.40	15.90	18.90	UNS-2A	0.66	0.89		4.02	M10x20	33.0	680
DN80	mm	72.90	43.00	10.00	151.00	91.20	96.40	114.10	160.70	200.00	600.00	226.00	0.63	0.74	1"-14	16.70	22.70	(F10)	102.00	M10x20	19.5	748
3"	inch	2.87	1.69	0.39	5.94	3.59	3.80	4.49	6.33	7.89	23.62	8.90	15.90	18.90	UNS-2A	0.66	0.89		4.02	M10x20	42.9	875
DN100	mm	97.38	45.00	12.00	158.80	107.00	123.00	124.00	170.50	211.00	600.00	252.00	0.63	0.74	1"-14	16.70	22.70	(F10)	102.00	M10x20	34.0	1333
4"	inch	3.83	1.77	0.47	6.25	4.21	4.84	4.88	6.71	8.30	23.62	9.92	0.74	0.63	UNS-2A	0.66	0.89		4.02	M10x20	74.8	1560

Components & materials

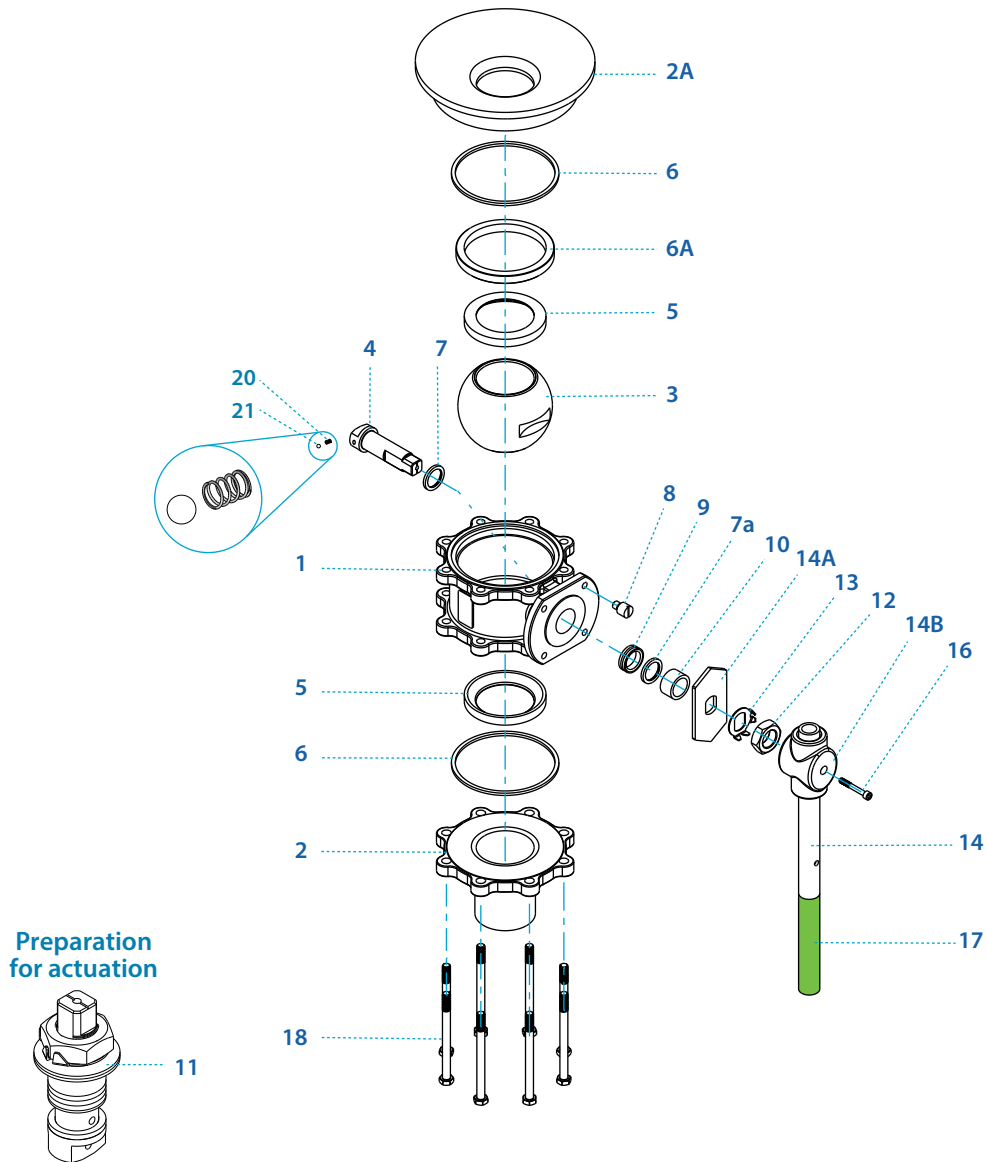

Item	Description	Material specification	Qty.
1	Body	A351 CF8M, A216 WCB, A105, A351 CN7M, A494 M35-1, A494 CW-12MW, A494 CX-2MW, A351 CK3MCuN, A995 CD3MN 4A, A995 CE3MN 5A	1
2	End	A351 CF3M, A216 WCB, A105, A351 CN7M, A494 M35-1, A494 CW-12MW, A494 CX-2MW, A351 CK3MCuN, A995 CD3MN 4A, A995 CE3MN 5A	1
2A	Pad	A479 316L, B473 N08020, B164 N04400, B574 N06022, B574 N10276, A479 S31254, A479 S31803, A479 S32750	1
3	Ball	A351 CF8M, B473 N08020, B164 N04400, B574 N06022, B574 N10276, A479 S31254, A479 S31803, A479 S32750	1
4	Stem	A479 316L, A564 Gr 630 H1150D 17-4PH, B473 N08020, B164 N04400, B574 N06022, B574 N10276, A479 S31254, A479 S31803, A479 S32750	1
5*	Seat	PTFE, RPTFE, CF PTFE, PEEK, TFM, UHMWPE, VESPEL, PVDF, DELRIN, PCTFE (KEL-F)	2
6*	Body seal	PTFE, RPTFE, TFM, UHMWPE, Graphite	2
6A	Support ring	A479 316L, B473 N08020, B164 N04400, B574 N06022, B574 N10276, A479 S31254, A479 S31803, A479 S32750	1
7*	Stem thrust seal	PEEK, CF PEEK, PCTFE (KEL-F), TFM ⁽²⁾ , CF PTFE ⁽²⁾	1

Item	Description	Material specification	Qty.
7a**	Anti-abrasion ring	PEEK, CF PEEK, PCTFE (KEL-F), TFM ⁽²⁾ , CF PTFE ⁽²⁾	1
8	Stop pin	A582 303	1
9*	stem seal	CF PTFE, TFM, Graphite ⁽²⁾	1
10	Follower	B783 316L	1
11	Disc spring	A693 631 17-7PH	2
12	Stem nut	A194 8M, EN3506-2 A4-80	1
13	Tab lock washer	A240 304	1
14	Wrench handle	A240 316L	1
14A	Stop plate	A240 430	1
14B	Wrench head	A351 CF8M	1
16	Wrench bolt	EN3506-1 A2-70/A4-80, A193 Gr B8/B8M	1
17	Sleeve	PVC	1
18	Body bolts	C.St 8.8 ZP, A193 B8, EN3506-1 A2-70	6-10
20	Anti static spring	A313 302	2
21	Anti static plunger	A479 304	2
23	Tag (not shown)	A167 304	1

* Repair kit components
 ** Only with HermetiX™ stem seal

⁽¹⁾ R48 Series is Habonim's standard valve design without the HermetiX™ stem seal construction.

⁽²⁾ This material can only be used as part of the R48 design.

Floating Ball Valves

Flush tank valves

General

3 Piece
standard

3 Piece
TuBore™

Ordering
code system

Ordering code system

The Habonim Flush tank identification code

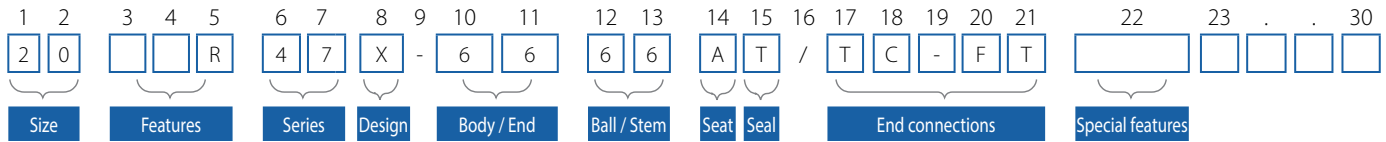

Size		
Code	inch	mm
05	½"	15
07	¾"	20
10	1"	25
12	1¼"	32
15	1½"	40
20	2"	50
25	2½"	65
30	3"	80
40	4"	100

Features	
A	Anti-Static
F	Fire safe
B	Full port
I	High purity Class 10000 assembly room
Q	Cavity filler seats
R	Flush tank
O ⁽¹⁾	Clean assembly for O ₂ service
M	Ammonia service
K	Chlorine service
V	Vacuum service

Series	
47	Three pcs
48	TuBore™

Design	
P ⁽²⁾	ISO pad basic design
X	HermetiX™ stem seal

Seat	
A	TFM
C	PCTFE
K	CF PEEK
L	Virgin PEEK
P	CF PTFE
R	15% glass filled RPTFE
S	VESPEL
T	PTFE
U	UHMWPE
Y	Derlin
W	PVDF

Ball / Stem	
6	S. Steel A479 316\316L
8	S. Steel A479 304\304L
M	17-4PH A564 Gr 630 H1150D
Z ⁽⁴⁾	Inconel 718 B637 N07718
I ⁽³⁾	Inconel 625 A494 CW-6MC
7	Monel B164 N04400
A	Alloy-20 B473 N08020
C	Alloy-C276 B574 N10276
W	Alloy-C22 B574 N06022
D	Duplex A479 S31803
K	Super duplex A479 S32750
S	254SMO A479 S31254

Body / End	
1	Bronze B62 C83600
4	C. steel A216 WCB / A105
9	C. steel A352 LCB
6	S. steel A351 CF8M
8	S. steel A351 CF8
7	Monel A494 M-35-1
I	Inconel 625 A494 CW-6MC
A	Alloy-20 A351 CN7M
C	Alloy-C276 A494 CW-12MW
W	Alloy-C22 A494 CX-2MW
D	Duplex A995 CD3MN 4A
K	Super duplex A995 CE3MN 5A
S	254SMO A351 CK3MCuN

Seal	
G	Expanded graphite
I	Impregnated graphite
R	15% glass filled RPTFE
T	PTFE
U	UHMWPE
V	Viton
B	NBR

End connections	
Welded	
BW5	Buttweld schd. 5
BW10	Buttweld schd. 10
BW	Buttweld schd. 40
BW80	Buttweld schd. 80
XBW	Extended buttweld schd. 40
SW	Socket weld
XSW	Extended socket weld
BWO	Buttweld tube OD
ETO	Extended tube OD
SWO	Socket weld tube OD
BWD	Buttweld DIN 11860
ETJ	Extended tube JIS
FT	Flush tank adaptive plate
FP	Flush pipe adaptive plate

Threaded	
NPT	ANSI B1.20.1 - national pipe taper thread
MNPT	Male NPT
BSPT	EN 10226-1 - british standard pipe taper thread
MBSPT	Male BSPT
DIN2999	EN 10226-1 - british standard pipe parallel thread
DIN3852	EN 10226-1 - british standard pipe parallel thread
AS5202	SAE internal straight thread

Clamp	
LL	Compression fitting (Imperial)
LM	Compression fitting (metric)
TC	Tri-clamp

Flanged	
150	ANSI B16.5 #150 RF
300	ANSI B16.5 #300 RF
PN16	EN1092 PN16 RF
PN40	EN1092 PN40 RF

Special features	
B	Body made from rolled bar
J2N05	Jacketed valve - number of ports (2), type (NPT) and size (1/2")
SRS	Self relief seat
P250	Ball with upstream pressure relief hole
PN	Ball with LTPN surface treatment
R	DD stem
G..	Internal surface finish (G24, G32)
E..	Electropolish body and ends (E24, E32)
Valve special stem seals	
HC	High cycle service
ORV	Viton O-ring based
ORB	NBR O-ring based
ORE	EPDM O-ring based
LAX	FDA compliant HermetiX™
PPX	CF PTFE thrust and X shape gasket

⁽¹⁾ Not applicable for 48 series

⁽²⁾ P design does not apply for 48 series, for non HermetiX™ construction use 48 with no suffix

⁽³⁾ Ball material only

⁽⁴⁾ Stem material only



www.habonim.com

Habonim USA

Toll Free Phone: 1-866-261-8400
Toll Free Fax: 1-866-243-9959
sales_usa@habonim.com

Habonim EUROPE

Tel: +34 640 384 759
sales_eu@habonim.com
sales_international@habonim.com

Habonim AUSTRALIA

Tel: +61 400 001 988
sales_au@habonimau.com

Habonim CHINA

Tel: + 86 21 64453190 *146
sales_china@habonim.com

Habonim ISRAEL

Tel: +972-4-6914911
Fax: +972-4-6914935
sales_international@habonim.com

Habonim UK

Tel: +44-1633-484554
Fax: +44-1633-482252
sales_uk@habonim.com

Habonim SINGAPORE

Tel: +65 6296 7828
Fax: +65 6299 3184
sales_Singapore@habonim.com



www.habonim.com



Three piece valves Cat.

