

CARBON STEEL DOUBLE OFFSET BUTTERFLY VALVE CLASS 150 PN20



Management
System
ISO 9001 : 2015



Certificate 3.1



Size : DN 50 to 600 mm (NPS 2" to 24")
Ends : Between Class 150 (PN20) flanges
Min Temperature : - 29°C
Max Temperature : + 210°C
Max Pressure : 20 Bars
Specifications : Double offset
Wafer type
Fire safe according to ISO 10497 : 2010
ISO 5211 mounting pad

Materials : Carbon steel ASTM A216 WCB

CARBON STEEL DOUBLE OFFSET BUTTERFLY VALVE CLASS 150 PN20

SPECIFICATIONS :

- 100% tightness
- Wafer type
- Between Class 150 (PN20) flanges
- Double offset
- Bidirectional with preferential flow direction indicated by the arrow
- Fire safe according to ISO 10497 : 2010
- ISO 5211 mounting pad
- Stainless steel CF8M disc
- Full crossing stem
- 10 positions ductile iron handle, with locking device up to DN150 (NPS 6")
- Gear box from DN 200 to DN600 (NPS 8" to 24")
- Inorganic zinc rich primer, gray color, 10 µm thickness
- Finish painting heat resisting aluminum Silver color RAL 1504, 30 µm thickness
- Ductile iron EN GJS-400-15 handle with silver painting RAL 9006 color

USE :

- Heating, geothermics, industrial cold, shipbuilding, petrochemical
- Steam : 10 bars maximum
- Min and max Temperature Ts : - 29°C to + 210°C
- Max Pressure Ps : 20 bars (see graph)
- When using at dead end of pipeline, reverse preferential flow direction

RANGE :

- Wafer type with carbon steel body , and handle **Ref. 1115** DN 50 to DN 150 (NPS 2" to 6")
- Wafer type with carbon steel body , and gear box **Ref. 1115** DN 200 to DN 600 (NPS 8" to 24")
- Gear box **Ref. 1193** from DN 50 to DN 350 (NPS 2" to 14")

ENDS :

- Between Class 150 (PN20) flanges

PRESSURE / TEMPERATURE GRAPH :

PRESSURE

(Bar)

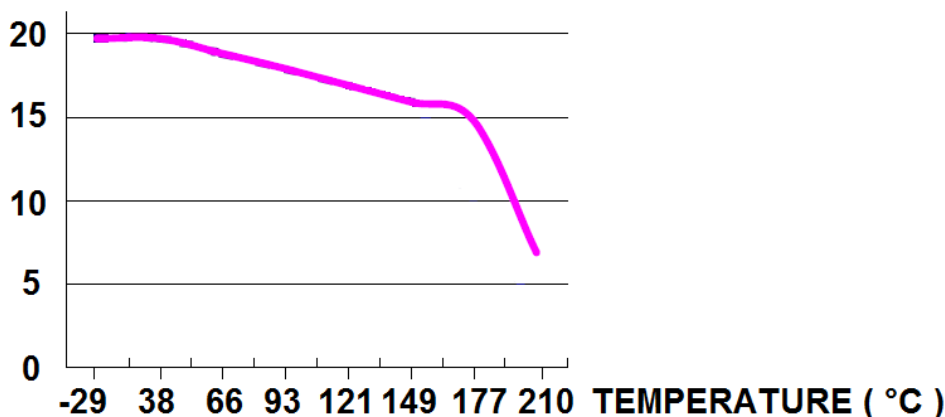

CARBON STEEL DOUBLE OFFSET BUTTERFLY VALVE CLASS 150 PN20

TORQUE VALUE (in Nm with safety coefficient of 30 % included) :

DN	50	65	80	100	125	150	200	250	300	350	400	450	500	600
NPS	2"	2"1/2	3"	4"	5"	6"	8"	10"	12"	14"	16"	18"	20"	24"
Torque (Nm) at 0 Bar	29	37	50	76	118	147	176	255	333	461	657	843	1078	1274
Torque (Nm) at 5 Bar	32	46	61	88	137	196	235	323	470	725	960	1058	1382	1617
Torque (Nm) at 10 Bar	39	61	76	103	170	225	294	421	549	833	1264	1362	1803	2225
Torque (Nm) at 15 Bar	43	69	92	118	194	265	353	480	686	990	1509	1705	2166	2783
Torque (Nm) at 20 Bar	49	83	107	140	223	294	421	568	862	1196	1686	2087	2920	3783

FLOW COEFFICIENT Kv (m3 / h) :

DN	Percent of Rated Travel									
	10%	20%	30%	40%	50%	60%	70%	80%	90%	100%
50	3,5	11,2	22,5	33,7	62,3	109,0	132,3	176,4	201,5	138,4
65	6,1	19,9	38,9	57,1	105,5	185,1	223,1	298,4	339,9	224,0
80	8,6	29,4	58,8	87,4	160,0	280,2	338,2	452,3	515,5	344,2
100	9,5	35,5	62,3	95,1	185,1	324,3	359,8	467,9	497,3	530,2
125	14,7	45,8	91,7	135,8	250,8	437,6	528,4	705,7	805,2	847,6
150	20,8	66,6	131,5	195,5	360,7	629,6	761,1	1017,1	1158,9	1189,2
200	36,3	118,5	234,4	347,7	472,2	661,6	851,0	1126,9	1254,1	1513,5
250	108,1	263,8	425,5	504,2	798,3	1089,7	1427,1	1781,7	2110,3	2306,6
300	147,0	358,9	578,6	834,6	1124,3	1517,9	2645,7	2987,3	3328,9	3776,1
350	192,0	437,6	688,4	1007,6	1395,9	1938,2	2700,2	3658,4	4635,8	5158,1
400	272,4	464,4	780,1	1145,1	1646,7	2149,2	3202,7	4666,0	5956,4	6713,2
450	339,0	818,2	1259,3	1764,4	2435,5	3388,6	4684,2	6106,9	7381,8	8090,1
500	443,7	1035,3	1586,2	2212,4	3031,4	4275,1	6216,8	7867,8	9523,2	10226,3
600	730,8	1609,5	2380,1	3382,5	4757,7	6628,4	9375,3	12475,0	15868,0	17178,2

CARBON STEEL DOUBLE OFFSET BUTTERFLY VALVE CLASS 150 PN20

MATERIALS VALVES :

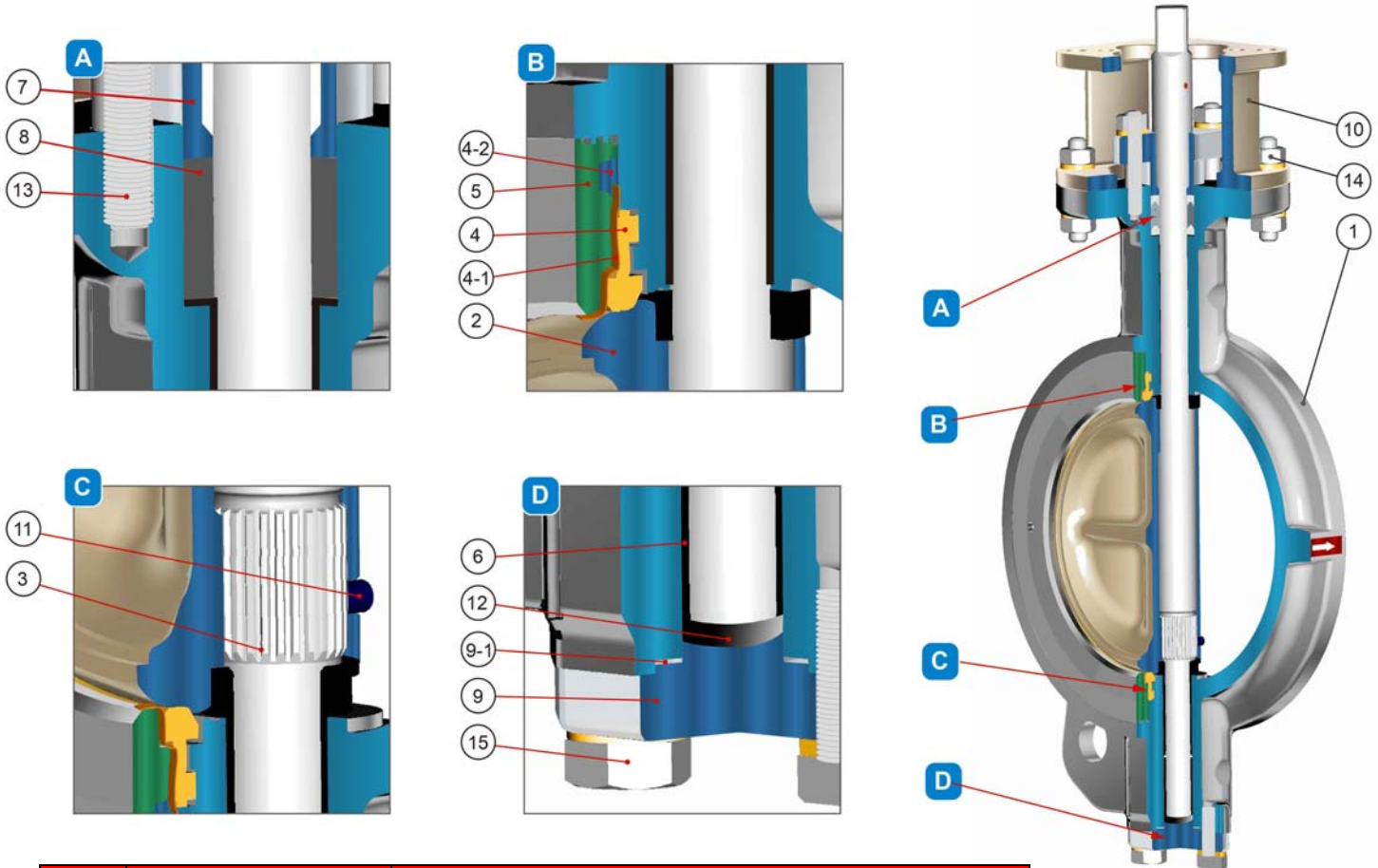

Item	Designation	Materials
1	Body	ASTM A216 WCB
2	Disc	ASTM A351 CF8M
3	Shaft	ASTM A564 630
4*	Seat	PTFE filled with 15% graphite
4-1	Metal seat	Inconel 718
4-2*	Gasket	Graphite
5	Retainer	ASTM A351 CF8
6*	Bushing	PTFE + AISI 316
7	Gland	ASTM A351 CF8
8*	Gland packing	Graphite
9	Bottom cover	ASTM A216 WCB
9-1*	Bottom cover gasket	Graphite
10	Yoke	ASTM A216 WCB
11*	Stop stud	ASTM A193 Gr. B8M
12*	Lock plate	PTFE filled with 15% graphite + AISI 316
13	Stud	ASTM A193 Gr. B8
14	Nut	ASTM A194 Gr. 8
15	Bolt	ASTM A193 Gr. B8

(* : Included in gaskets kit)

CARBON STEEL DOUBLE OFFSET BUTTERFLY VALVE CLASS 150 PN20

MATERIALS GEARBOX DN50 – 350 (NPS 2" to 14") :

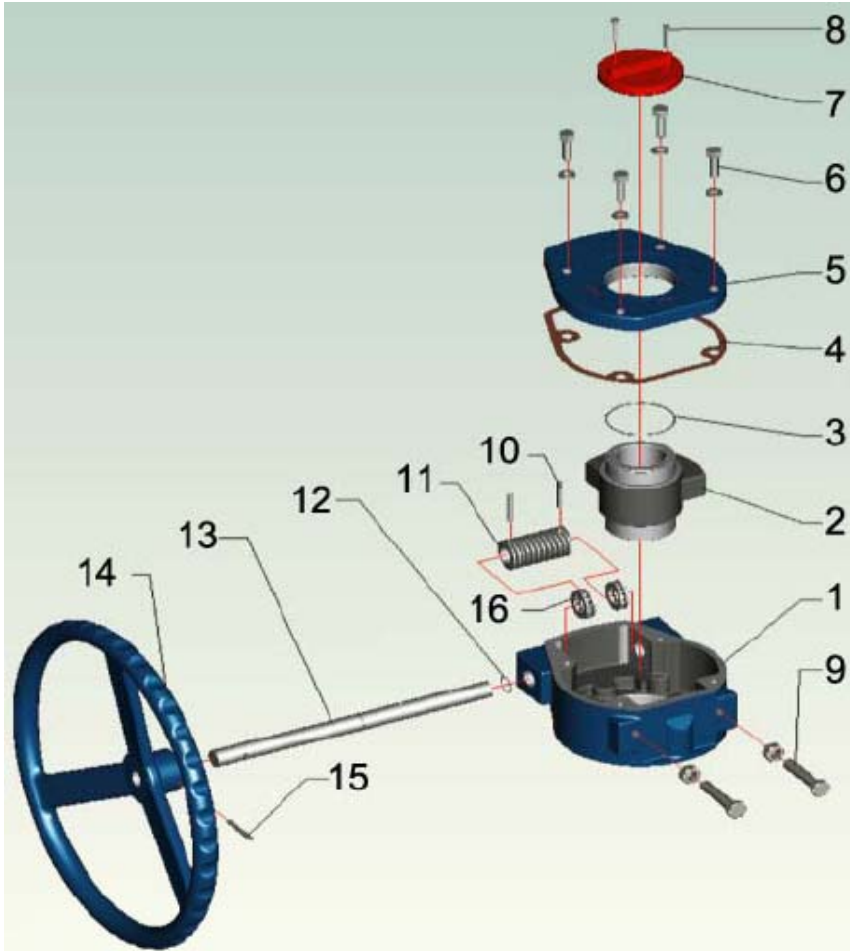

Item	Designation	Materials
1	Body	Cast iron
2	Worm gear	Ductile iron
3	O ring	NBR
4	Gasket	Paper
5	Cover	Cast iron
6	Screw	Steel
7	Indicator	Cast iron
8	Screw	Steel
9	Stop bolt	Steel
10	Pin	Steel
11	Worm	Steel
12	O ring	NBR
13	Worm shaft	Steel
14	Handwheel	Cast iron
15	Pin	Steel
16	Bearing	Steel

CARBON STEEL DOUBLE OFFSET BUTTERFLY VALVE CLASS 150 PN20

MATERIALS GEARBOX DN400 – 600 (NPS 16" to 24") :

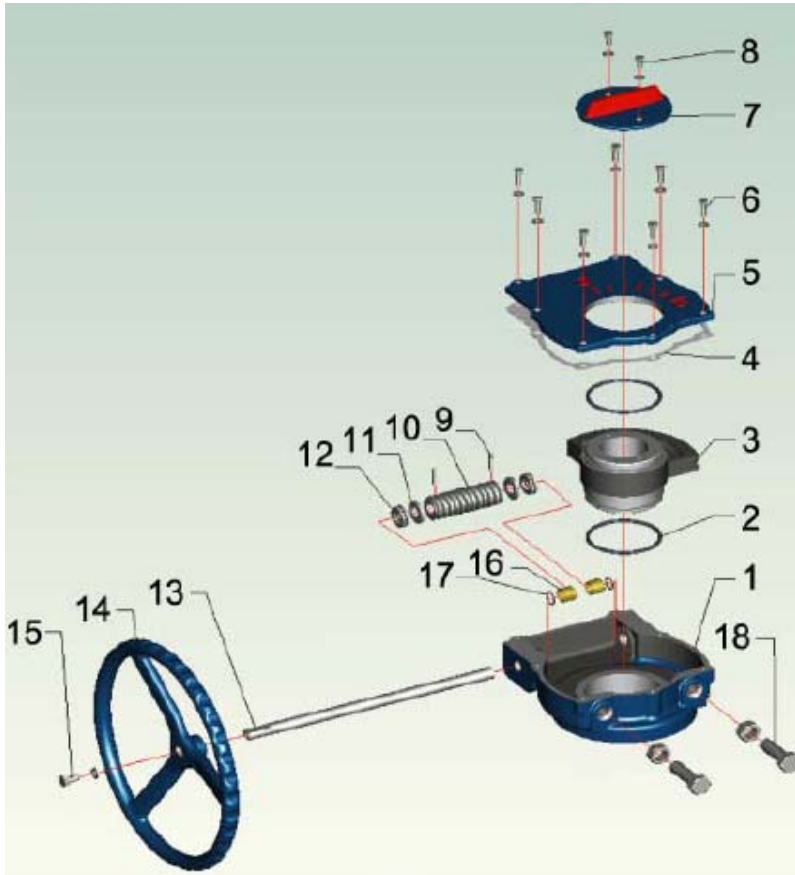

Item	Designation	Materials
1	Body	Cast iron
2	O ring	NBR
3	Worm gear	Ductile iron
4	Gasket	Paper
5	Cover	Cast iron
6	Screw	Steel
7	Indicator	Cast iron
8	Screw	Steel
9	Pin	Steel
10	Worm	Steel
11	Ring	Steel
12	Bearing	Steel
13	Worm shaft	Steel
14	Handwheel	Cast iron
15	Screw	Steel
16	Bushing	Copper
17	O ring	NBR
18	Stop bolt	Steel

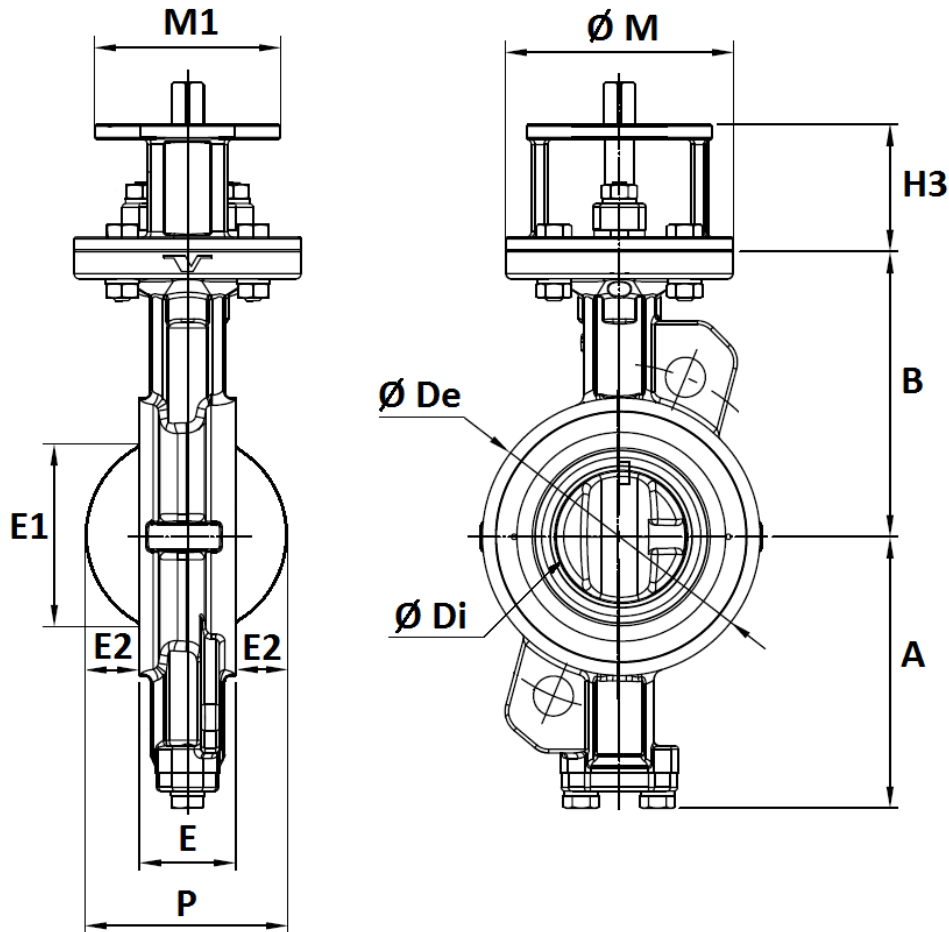
CARBON STEEL DOUBLE OFFSET BUTTERFLY VALVE CLASS 150 PN20
VALVE SIZE DN50 - 150 (in mm) :

NPS	2"	2"1/2	3"	4"	5"	6"
DN	50	65	80	100	125	150
E	43	46	47	53	57	56
A	99	110	128	150	163	176
B	118	125	140	157	170	185
H3	60	60	70	70	70	70
Ø M	90	90	125	125	125	125
M1	70	70	102	102	102	102
P	47	76	91	103	129	156
E1	49.5	62.3	65.9	93	120	149
E2	2	15	22	25	36	50
Ø De	92	108	126	153	184	212
Ø Di	37	63	78	95	118	143
Min pipe diameter	49	62	78	93	120	149
Weight (in Kg)	3.9	4.5	7	9	12	13.5

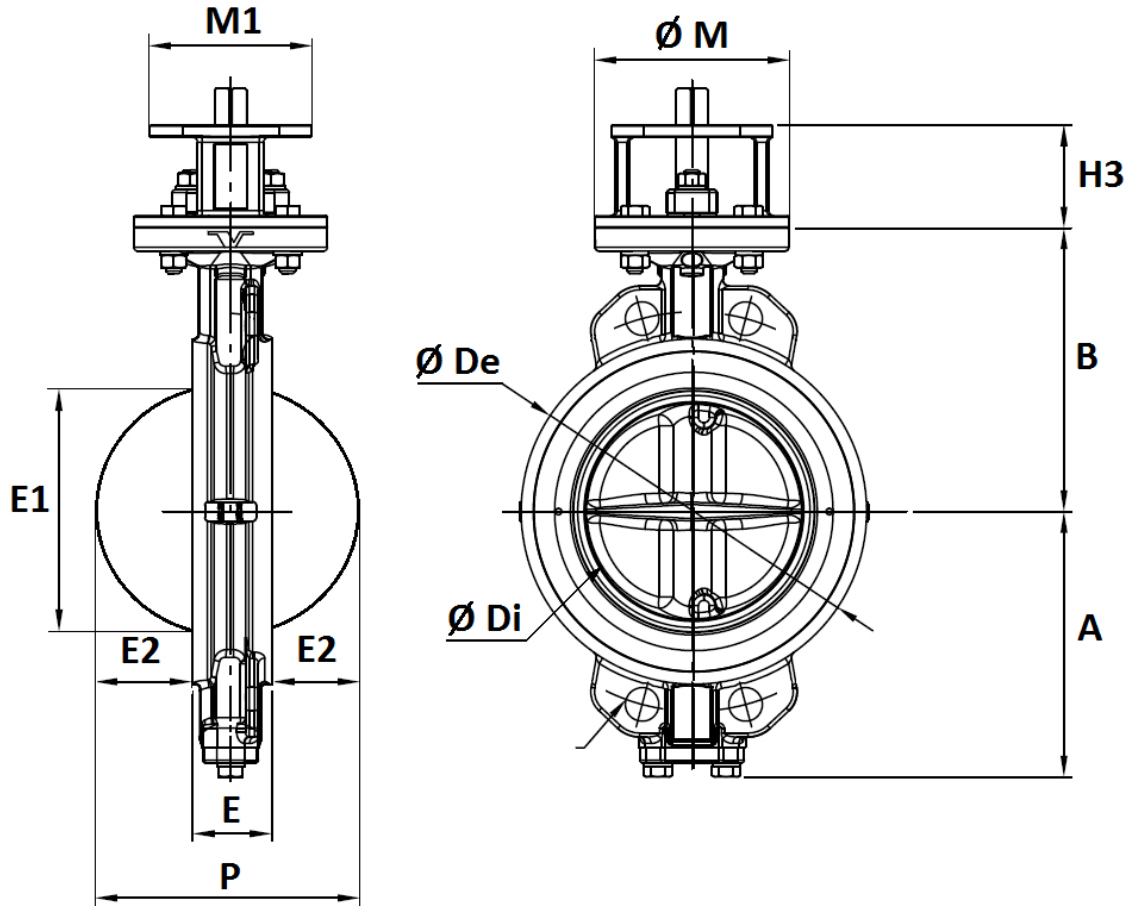
CARBON STEEL DOUBLE OFFSET BUTTERFLY VALVE CLASS 150 PN20
VALVE SIZE DN200 - 400 (in mm) :

NPS	8"	10"	12"	14"	16"
DN	200	250	300	350	400
E	62	68	78	78	102
A	206	238	269	306	342
B	220	260	290	326	370
H3	80	80	100	100	120
Ø M	150	150	175	175	210
M1	125	125	160	160	195
P	202	248	290	328	382
E1	196	243	289	329	377
E2	70	90	106	125	140
Ø De	268	326	375	416	476
Ø Di	187.6	235.5	282	322	371
Min pipe diameter	196	243	289	329	377
Weight (in Kg)	22	32	48	66	107

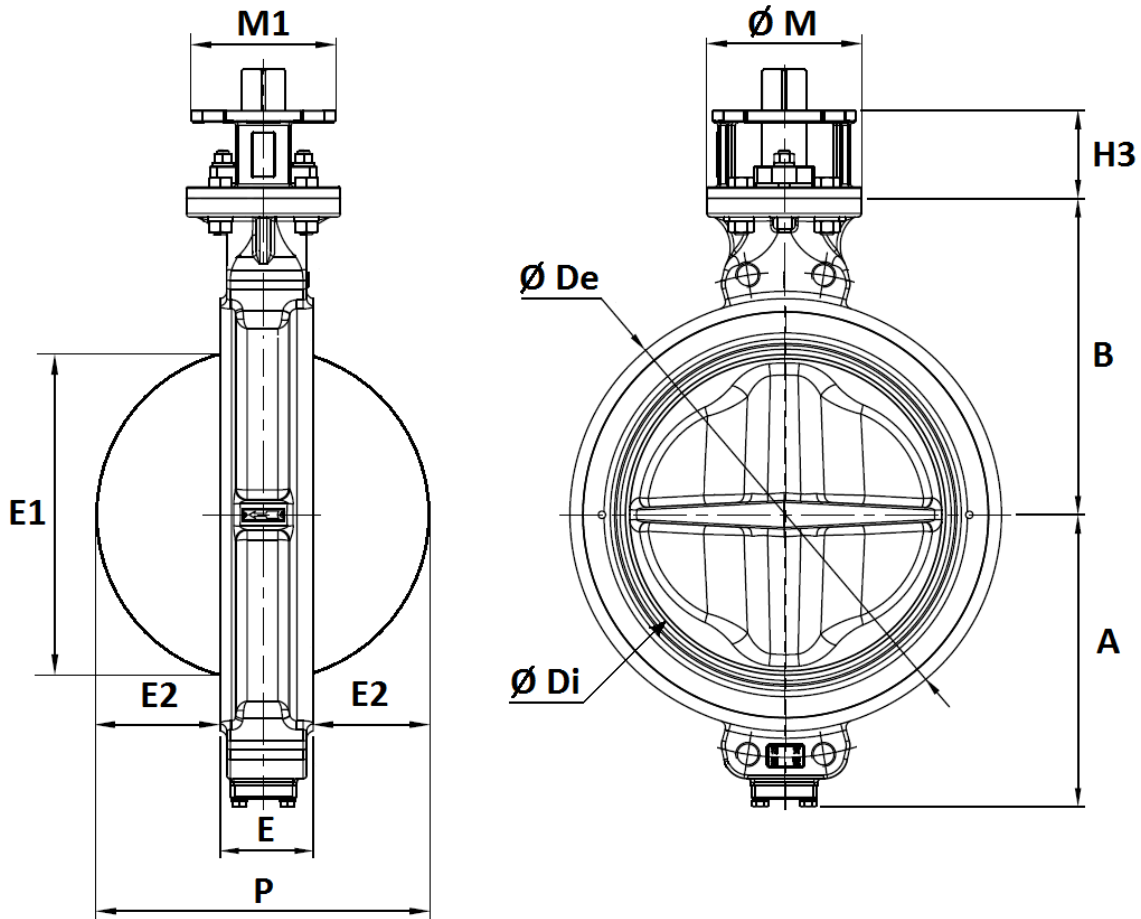
CARBON STEEL DOUBLE OFFSET BUTTERFLY VALVE CLASS 150 PN20
VALVE SIZE DN450 - 600 (in mm) :

NPS	18"	20"	24"
DN	450	500	600
E	114	127	154
A	370	399	455
B	395	430	490
H3	120	120	150
Ø M	210	210	300
M1	195	195	300
P	428	481	574
E1	423	471	572
E2	157	177	210
Ø De	534	588	692
Ø Di	418	466	570
Min pipe diameter	423	471	572
Weight (in Kg)	130	163	278

CARBON STEEL DOUBLE OFFSET BUTTERFLY VALVE CLASS 150 PN20

HANDLE SIZE (in ductile iron EN GJS-400-15 with silver painting RAL 9006 color) :

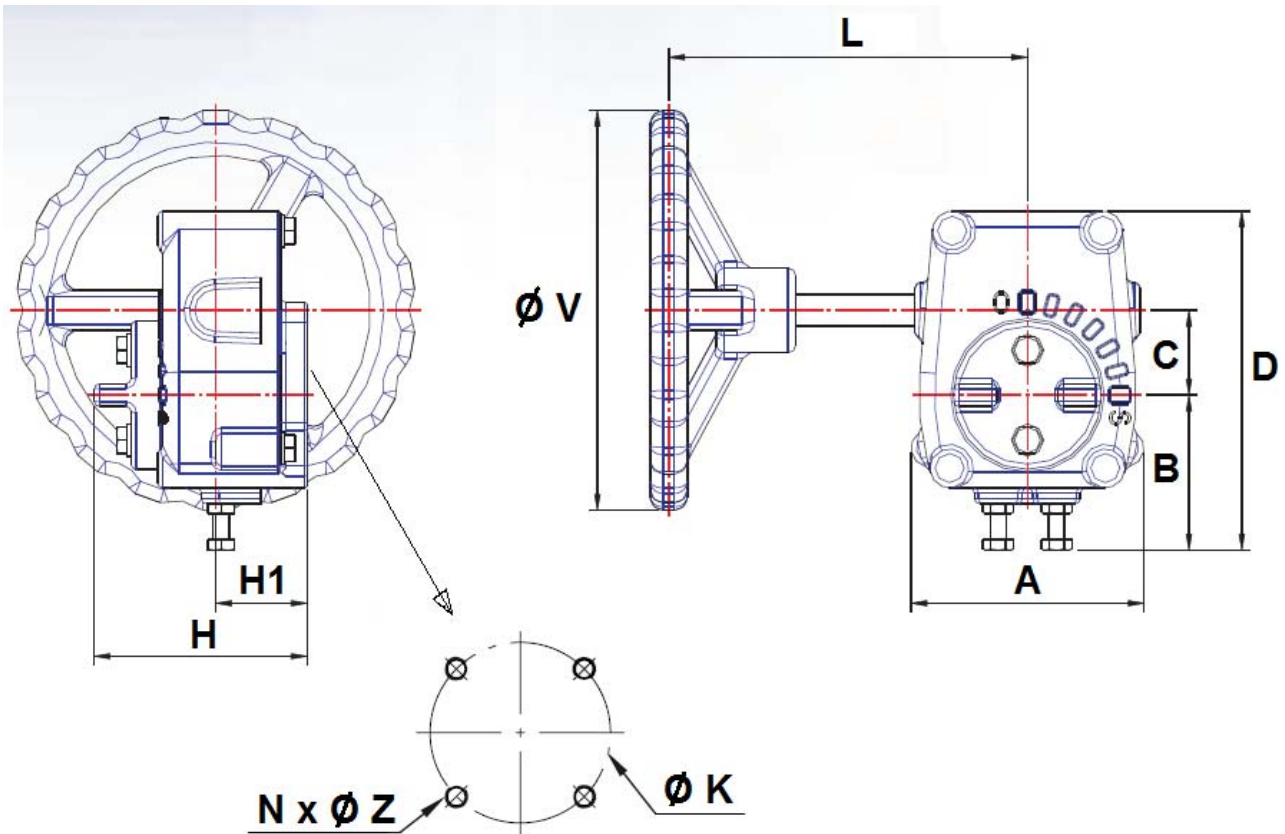

DN	50	65	80	100	125	150
NPS	2"	2"1/2	3"	4"	5"	6"
L	200	200	250	250	355	355
Weight (Kg)	0.7	0.7	0.8	0.8	1.6	1.6

CARBON STEEL DOUBLE OFFSET BUTTERFLY VALVE CLASS 150 PN20
GEARBOX SIZE DN 50-350 (NPS 2" to 14") :

DN	50-65	80	100	125-150	200	250	300-350
NPS	2"-2 1/2"	3"	4"	5"-6"	8"	10"	12"-14"
L	155	155	195	195	258	258	346
A	87	87	117	117	153	153	181
B	49	49	81	81	97	97	102
C	41	41	63	63	61	61	81
D	130	130	176	176	186	186	223
H	81	81	91	91	88	88	117
H1	37	37	41.5	41.5	41	41	52
Ø V	150	150	200	200	310	310	400
Ø K	70	70	102	102	125	125	140
ISO	F07	F07	F10	F10	F12	F12	F14
N x Ø Z	4 x M8	4 x M8	4 x M10	4 x M10	4 x M12	4 x M12	4 x M16
Weight (Kg)	3.3	3.3	7.5	7.5	9	9	22
Ref.	1193001	1193002	1193003	1193004	1193005	1193006	1193007

CARBON STEEL DOUBLE OFFSET BUTTERFLY VALVE CLASS 150 PN20

GEARBOX SIZE DN 400-600 (NPS 16" to 24"):

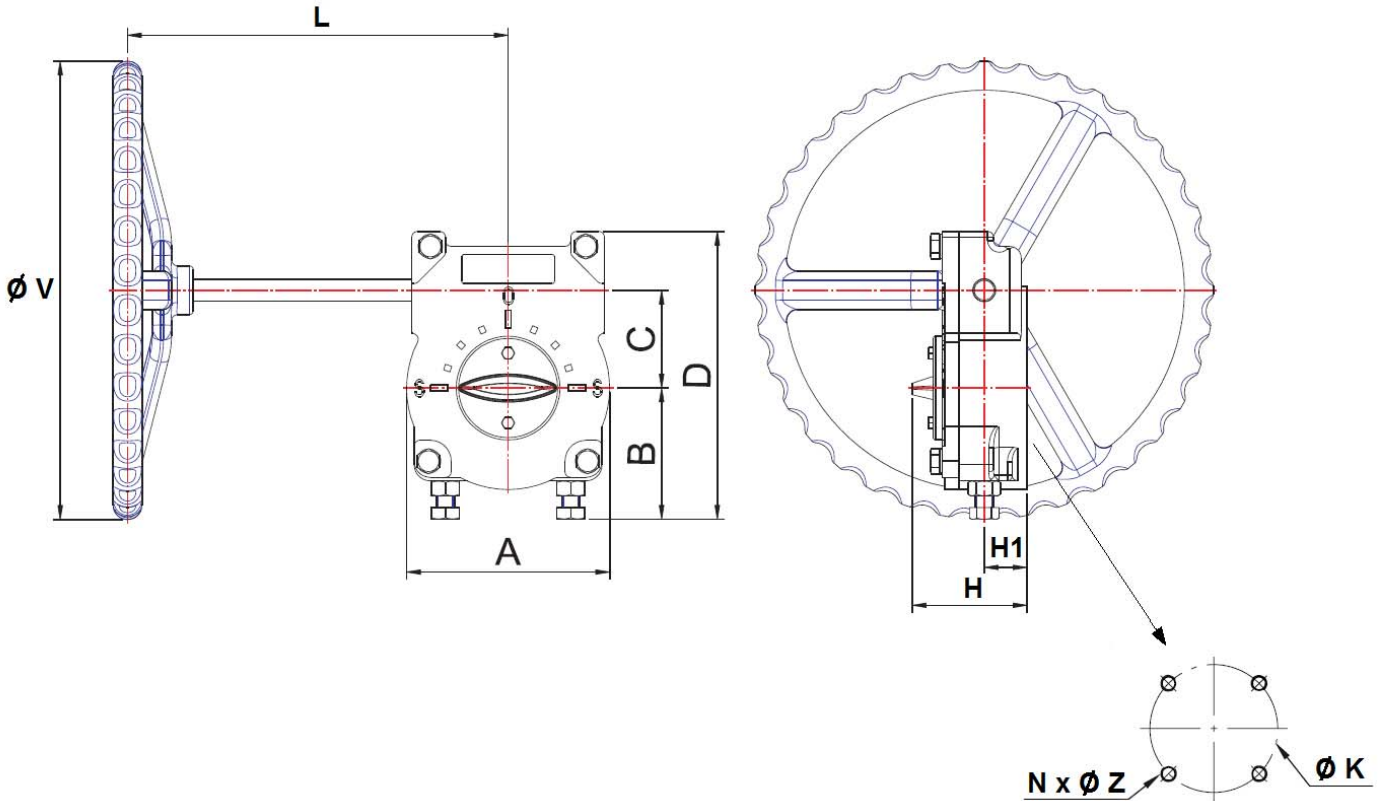

DN	400-500-600
NPS	16"-20"-24"
L	307
A	251
B	113
C	123
D	293
H	127
H1	56
Ø V	400
Ø K	165
ISO	F16
N x Ø Z	4 x M20
Weight (Kg)	35

CARBON STEEL DOUBLE OFFSET BUTTERFLY VALVE CLASS 150 PN20

ISO MOUNTING PAD AND STEM SIZE (in mm) :

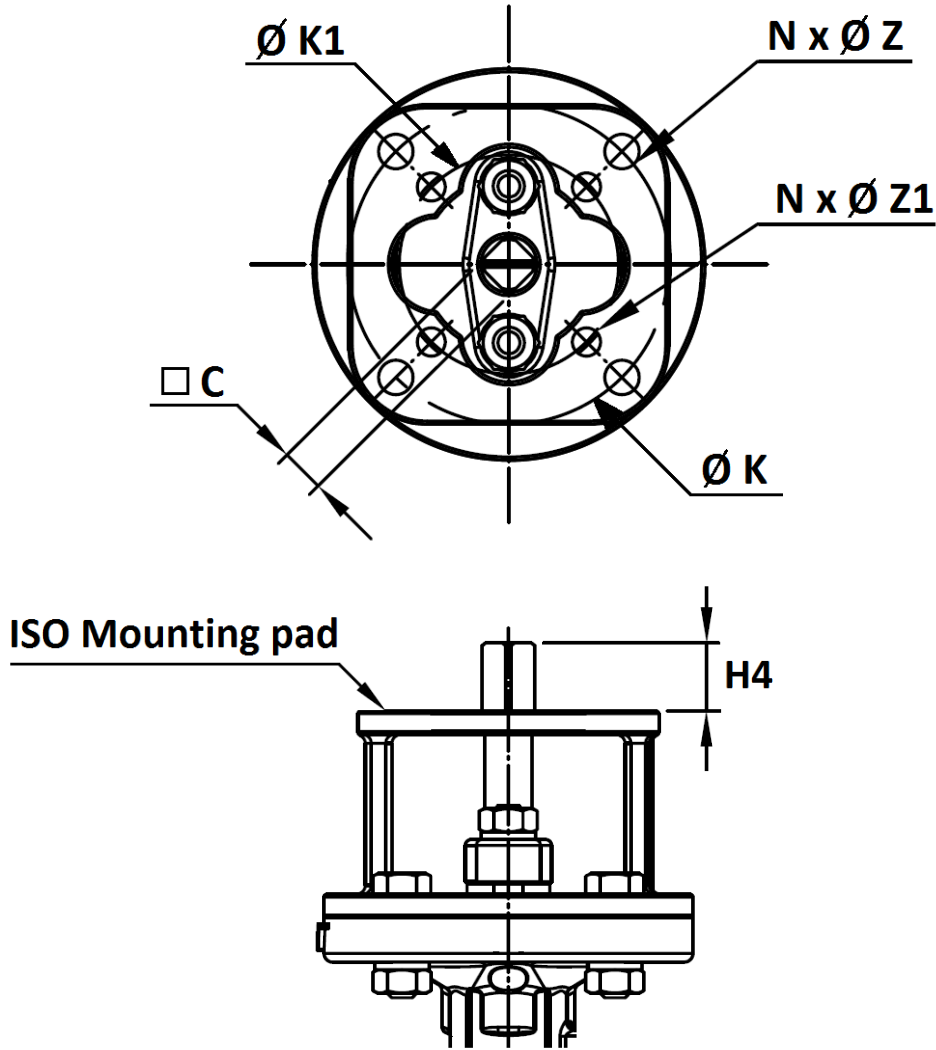

NPS	2"	2"1/2	3"	4"	5"	6"	8"	10"	12"	14"	16"	18"	20"	24"
DN	50	65	80	100	125	150	200	250	300	350	400	450	500	600
C	11	11	14	14	17	17	19	22	27	27	36	36	46	46
H4	18	18	23	23	23	23	28	28	37	37	47	47	56	56
Ø K	70	70	102	102	102	102	125	125	140	140	165	165	165	254
ISO	F07	F07	F10	F10	F10	F10	F12	F12	F14	F14	F16	F16	F16	F25
N x ØZ	4 x 8	4 x 8	4 x 10	4 x 10	4 x 10	4 x 10	4 x 12	4 x 12	4 x 16	4 x 16	4 x 22	4 x 22	4 x 22	8 x 17
Ø K1	50	50	70	70	70	70	102	102	125	125	140	140	140	-
ISO1	F05	F05	F07	F07	F07	F07	F10	F10	F12	F12	F14	F14	F14	-
NxØZ1	4 x 6	4 x 6	4 x 8	4 x 8	4 x 8	4 x 8	4 x 10	4 x 10	4 x 12	4 x 12	4 x 16	4 x 16	4 x 16	-

CARBON STEEL DOUBLE OFFSET BUTTERFLY VALVE CLASS 150 PN20

BETWEEN FLANGES CLASS 150 PN20 SIZE (in mm) :

DN 50 – 150

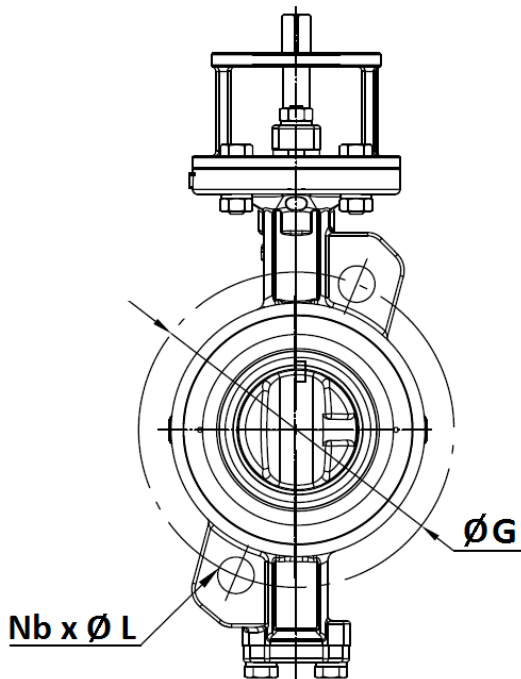

DN 200 - 400

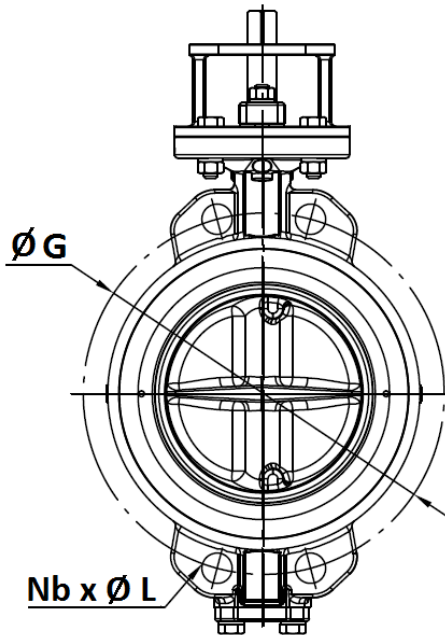

DN 450 - 600

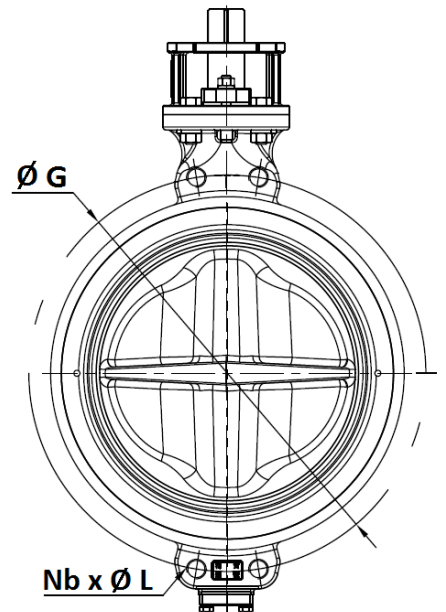

NPS	2"	2"1/2	3"	4"	5"	6"	8"	10"	12"	14"	16"	18"	20"	24"
DN	50	65	80	100	125	150	200	250	300	350	400	450	500	600
Ø G	120.6	139.7	152.4	190.5	215.9	241.3	298.4	362	431.8	476.2	539.8	577.8	635	749.3
Nb x ØL	2 x 19	2 x 19	2 x 19	2 x 19	2 x 22.2	2 x 22.2	4 x 22.2	4 x 25.4	4 x 25.4	4 x 28.6	4 x 28.6	4x M30	4x M30	4x M33
Ref.	1115050	1115065	1115080	1115100	1115125	1115150	1115200	1115250	1115300	1115350	1115400	1115450	1115500	1115600

CARBON STEEL DOUBLE OFFSET BUTTERFLY VALVE CLASS 150 PN20

BOLTING SIZE (in mm, not included with valves) :

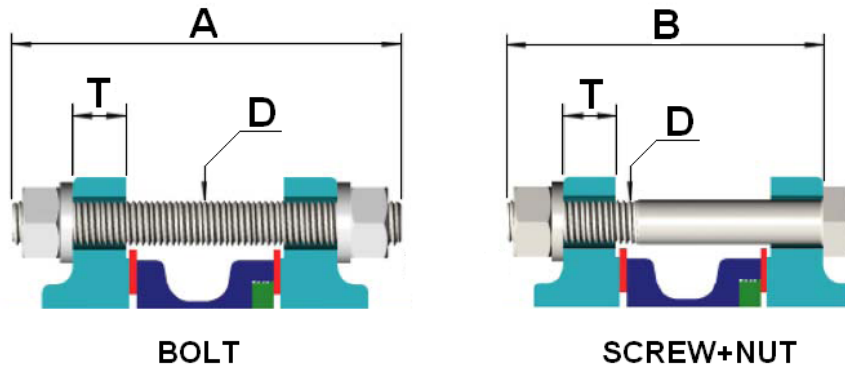

DN	50	65	80	100	125	150	200	250	300	350	400	450	500	600
NPS	2"	2"1/2	3"	4"	5"	6"	8"	10"	12"	14"	16"	18"	20"	24"
A	135	135	140	155	175	175	185	200	215	230	265	290	305	360
B	125	125	130	140	155	155	165	180	195	205	240	265	280	330
D	M16	M16	M16	M16	M20	M20	M20	M24	M24	M27	M27	M30	M30	M33
T	22	22	24	24	26	28	30	32	34	38	40	48	48	58

GEARBOX SPECIFICATIONS :

DN	50-65	80	100	125-150	200-250	300-350	400-600
NPS	2"-2"1/2	3"	4"	5"-6"	8"-10"	12"-14"	16"-24"
Ref.	1193001	1193002	1193003	1193004	-	-	-
Ratio factor	40 :1	40 :1	36 :1	36 :1	36 :1	52 :1	70 :1
Number of cycles for opening or closing	10	10	9	9	9	13	17.5
Input torque (Nm)	24.5	24.5	54	54	109	150	225
Output torque (Nm)	245	245	490	490	980	1960	3922

CARBON STEEL DOUBLE OFFSET BUTTERFLY VALVE CLASS 150 PN20**STANDARDS :**

- Fabrication according to ISO 9001:2015
- DIRECTIVE 2014/68/EU : CE N° 0035
Risk Category III module H
- Designing according to API 609
- Marking according to MSS SP-25
- Tightness tests according to ISO 5208, Rate A
- Between flanges according to ANSI B16-5 Class 150 (PN20)
- ISO 5211 mounting pad
- Length according to EN 558 series 20 (ISO 5752 series 20)
- Fire safe according to ISO 10497 : 2010
- ATEX Group II Category 2 G/2D Zone 1 & 21 Zone 2 & 22 according to directive 2014/34/EU(Optional marking)
- SIL2 according to IEC/EN 61508, SIL 3 possible according to installation

ADVICE : Our opinion and our advice are not guaranteed and SFERACO shall not be liable for the consequences of damages.
The customer must check the right choice of the products with the real service conditions.

CARBON STEEL DOUBLE OFFSET BUTTERFLY VALVE CLASS 150 PN20
INSTALLATION INSTRUCTIONS
GENERAL GUIDELINES :

- Ensure that the valves to be used are appropriate for the conditions of the installation (type of fluid, pressure and temperature).
- Be sure to have enough valves to be able to isolate the sections of piping as well as the appropriate equipment for maintenance and repair.
- Ensure that the valves to be installed are of correct strength to be able to support the capacity of their usage.
- **Installation of all circuits should ensure that their function can be automatically tested on a regular basis (at least two times a year).**

INSTALLATION INSTRUCTIONS :

- **Before installing the valves, clean and remove any objects from the pipes** (in particular bits of sealing and metal) which could obstruct and block the valves.
- **Ensure that both connecting pipes either side of the valve (upstream and downstream) are aligned (if they're not, the valves may not work correctly).**
- **Make sure that the two sections of the pipe (upstream and downstream) match, the valve unit will not absorb any gaps. Any distortions in the pipes may affect the tightness of the connection, the working of the valve and can even cause a rupture.** To be sure, place the kit in position to ensure the assembling will work.
- **If sections of piping do not have their final support in place, they should be temporarily fixed. This is to avoid unnecessary strain on the valve.**
- Tighten the bolts in cross as the example below :



Bolting size	Max torque (Nm)
M16	150
M20	270
M22	434
M24	450
M26	650
M27	700
M28	815
M30	950
M32	1140
M33	1300
M36	1700

CARBON STEEL DOUBLE OFFSET BUTTERFLY VALVE CLASS 150 PN20

INSTALLATION INSTRUCTIONS (SUITE) :

- The disc must move easily inside the pipe.
- Valves must be opened during cleaning operation.
- Vales must be installed in horizontal position or in vertical position with handle at the top :

OK



OK



NO



- Tests must be done with a cleaned pipe.
- Tests must be done with opened valve. Test pressure must not be higher than the valve specification according to ISO 5208.
- Then open slowly the valve.
- **Do not mount butterfly valves with stainless steel pressed collars and turning flanges without strias.**
- **And not on flat face flanges without strias (example : painted cast iron fittings)**

MAINTENANCE :

- We recommend to operate fully the valve 1 to 2 times per year.
- During maintenance operation, ensure that the pipe isn't under pressure, that there's no fluid in the pipe and that the valve is isolated. If there's a fluid in the pipe , evacuate it. Ensure that there are no risks due to the temperature or the fluid (like acids). If the fluid is corrosive , inert the installation before maintenance operation.