



Alpha



PNEUMATIC RACK & PINION ACTUATORS 90° - 120° - 180°

ALUMINIUM



JANUARY 2006

ALPHAIR PNEUMATIC ACTUATORS

90° - I Series

120° - Y Series

180° - X Series

ALPHAIR pneumatic actuators are made by the best manufacture experience on design, material, machining, assembly.

The internal rotation adjusting system is ever free of side-loads on pistons, shaft and body at every feeding pressure.

HEAVY DUTY, MAXIMUM LIFETIME!

ALPHAIR pneumatic actuators are compact, heavy and reliable. Easy assembly/change on every mean of valve.

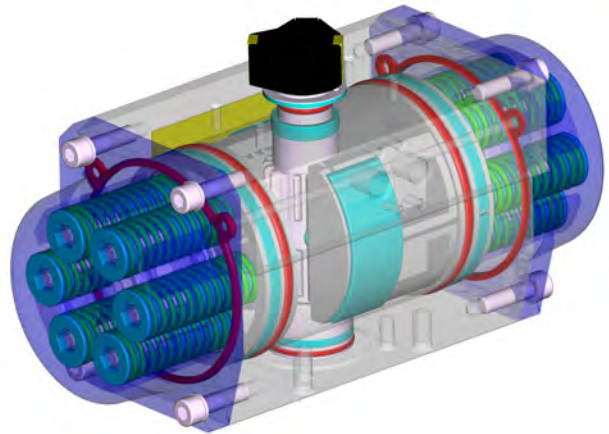

STANDARD VERSION FEATURES

- **ASTM 6063 extruded Aluminium Body**, inside surface finish Ra=0,4-0,6. 50 micron Hard Anodizing.
- **ASTM B179 die-casted Aluminium alloy Pistons**, 15 micron Anodizing.
- **ASTM B179 die-casted Aluminium alloy Covers**, painted with 60-80 micron polyester powder.
- **Carbon steel Shaft**, 20 micron nickel-plated. Optional in Stainless Steel AISI 316 (A4).
- Screws in Stainless Steel AISI 304 (A2).
- Seals in nitrile rubber NBR. Optional HIGH Temperature = VITON. Optional LOW Temperature = SILICONE.
- Bearings in low friction acetal resin LAT-LUB, easily replaceable for maintenance. Optional HIGH/LOW Temperature = PA 66.
- Pre-compressed Spring Cartridges, easily replaceable for maintenance, 60-80 micron polyester painted.
- Standard grease: Mollibdenum Bisulphide. Optional: special grease for HIGH/LOW Temperature.
- Several special protections available for chemical, pharmaceutical, food and industrial environments.
- Double lower drilling for valve fastening and centering, according to **ISO 5211-DIN 3337 Standards**.
- Double square lower female shaft key (starlike), according to **ISO 5211-DIN 3337 Standards** for assembly on valves with square key on line (0°) and diagonal key (45°).
- Solenoid connections according to **NAMUR VDI\VDE-3845 Standards**.
- Top drilling for accessories fastening, and upper shaft end according to **NAMUR VDI\VDE-3845 Standards**.
- Position indicator on request, enabling switch-box assembly on top.
- Aluminium adhesive nameplates, with progressive serial number punched.
- Lubrification carried out by the manufacturer, guaranteed for min. 1.000.000 operations.
- Running test and 100% seal test carried out with electronic equipment and certification of each individual product.
- Standard execution for temperatures from -20°C to +80°C (optional, special execution for extreme temperatures).
- According to **ATEX-94-9-CEE Standard** for explosive environment; STANDARD version actuator: II 2GD c Tmax = 95°C.

AIR SUPPLY	TEMPERATURE RANGE	FEEDING PRESSURE	TURNING ROTATION RANGE
Dry or lubricated filtered compressed air.	Standard -20° +80°C (-4 +175°F)	8 bar/120 psi – CONTINUOUS 10 bar/142 psi - MAXIMUM	+/- 5°
	LOW Temperature -40° +80°C (-40 + 175°F) HIGH Temperature -20° +150°C (-4 + 300°F)		

I Series = 90°
Y Series = 120°
X Series = 180°

DOUBLE ACTING TORQUE RATINGS IN Nm

TYPE	AIR SUPPLY IN BAR							
	3	4	5	6	7	8	9	10
AP 032	-	5,0	6,3	7,6	8,8	10,0	11,4	12,6
AP 042	6,5	8,7	10,9	13,0	15,2	17,3	19,5	21,7
AP 050	9,2	12,3	15,4	18,5	21,5	24,6	27,7	30,8
AP 063	16,5	22,0	27,5	33,0	38,5	44,0	49,5	55,0
AP 075	35,1	46,8	58,5	70,2	81,9	93,6	105,3	117,0
AP 085	53,4	71,2	89,0	106,9	124,7	142,4	160,3	178,1
AP 100	83,2	110,9	138,6	166,4	194,1	221,8	249,5	277,3
AP 115	137,2	183,0	228,7	274,5	320,2	366,0	411,7	457,5
AP 125	180,5	240,7	300,9	361,1	421,2	481,4	541,6	601,8

I Series = 90°

AP 145	260,1	346,8	433,5	520,2	606,9	693,6	780,3	867,0
AP 160	355,0	473,4	591,7	710,1	828,4	946,8	1065,1	1183,5
AP 180	479,0	638,6	798,3	958,0	1118,6	1277,3	1437,0	1597,6
AP 200	665,6	887,5	1109,4	1333,3	1553,1	1775,0	1996,9	2218,8
AP 240	1117,6	1490,2	1862,7	2235,3	2607,8	2980,4	3352,9	3725,4
AP 270	1617,6	2156,8	2696,0	3235,2	3774,4	4313,6	4852,8	5392,0
AP 330	2929,5	3906,0	4882,4	5858,9	6835,4	7811,9	8788,4	9764,9

SINGLE ACTING TORQUE RATINGS IN Nm

I Series = 90°

TYPE	N° OF SPRINGS PER SIDE OF PISTON	AIR SUPPLY IN BAR										SPRING STROKE			
		3		4		5		6		7		8		90°	0°
		0°	90°	0°	90°	0°	90°	0°	90°	0°	90°	0°	90°		
AP 042	3	-	-	-	-	7,1	4,1	9,3	6,3	11,5	8,5	13,7	10,7	6,8	3,8
	4	-	-	-	-	-	-	8,1	4,1	10,2	6,2	12,4	8,4	9,0	5,0
AP 050	3	5,7	3,5	8,9	6,6	12,0	9,6	15,1	12,7	18,1	15,7	21,2	18,8	5,7	3,5
	4	-	-	7,7	4,7	10,8	7,7	13,9	10,8	16,9	13,8	20,0	16,9	7,7	4,7
	5	-	-	-	-	9,6	5,8	12,7	8,9	15,7	11,9	18,8	15,0	9,6	5,8
	6	-	-	-	-	8,4	3,9	11,5	7,0	14,5	10,0	17,6	13,1	11,5	7,0
AP 063	3	9,4	6,3	14,9	11,7	20,4	17,2	25,9	22,7	31,4	28,2	36,9	33,7	10,2	7,2
	4	-	-	12,3	8,3	17,8	13,8	23,3	19,3	28,8	24,8	34,3	30,3	13,7	9,7
	5	-	-	-	-	15,4	10,4	20,9	15,9	26,4	21,4	31,9	26,9	17,1	12,1
	6	-	-	-	-	13,0	7,0	18,5	12,5	24,0	18,0	29,5	23,5	20,5	14,5
AP 075	3	22,5	12,6	34,2	24,4	46,0	36,1	57,7	47,8	69,4	59,5	81,1	71,2	22,5	12,6
	4	-	-	30,0	16,9	41,8	28,6	53,5	40,3	65,2	52,0	76,9	63,7	30,0	16,9
	5	-	-	-	-	37,6	21,1	49,3	32,8	61,0	44,5	72,7	56,2	37,6	21,1
	6	-	-	-	-	33,4	13,6	45,1	25,3	56,8	37,0	68,5	48,7	45,1	25,3
AP 085	3	34,5	18,9	52,4	36,7	70,2	54,5	88,0	72,3	105,8	90,1	123,6	107,9	34,5	18,9
	4	-	-	46,1	25,2	63,9	43,0	81,7	60,8	99,5	78,6	117,3	96,4	46,1	25,2
	5	-	-	-	-	57,6	31,5	75,4	49,3	93,2	67,1	111,0	84,9	57,6	31,5
	6	-	-	-	-	51,5	20,0	69,1	37,8	86,9	55,6	104,7	73,4	69,1	37,8
AP 100	3	53,2	30,0	80,9	57,7	108,7	85,4	136,4	113,1	164,1	140,8	191,8	168,5	53,2	30,0
	4	-	-	70,9	40,0	98,7	67,7	126,4	95,4	154,1	123,1	181,8	150,8	70,9	40,0
	5	-	-	-	-	88,7	50,0	116,4	77,7	144,1	105,4	171,8	133,1	88,7	50,0
	6	-	-	-	-	78,7	32,2	106,4	60,0	134,1	87,7	161,8	115,4	106,4	60,0
AP 115	3	84,3	53,0	130,0	98,8	175,8	144,5	221,6	190,3	267,3	236,0	313,0	281,7	84,3	53,0
	4	-	-	112,3	70,7	158,1	116,4	203,9	162,2	249,6	207,9	295,3	253,6	112,3	70,7
	5	-	-	-	-	140,4	88,3	186,2	134,1	231,9	179,8	277,6	225,5	140,4	88,3
	6	-	-	-	-	122,7	60,2	168,5	106,0	214,2	151,7	259,9	197,4	168,5	106,0
AP 125	3	116,8	63,7	177,0	123,9	237,3	184,1	297,5	244,2	357,6	304,3	417,7	364,4	116,8	63,7
	4	-	-	155,7	85,0	216,0	145,2	276,2	205,3	336,3	265,4	396,4	325,5	155,7	85,0
	5	-	-	-	-	194,7	106,3	254,9	166,4	315,0	226,5	375,1	286,6	194,7	106,3
	6	-	-	-	-	173,4	67,4	233,6	127,5	293,7	187,6	353,8	247,7	233,6	127,5
AP 145	3	158,0	92,0	245,0	179,0	332,0	265,0	418,0	352,0	505,0	439,0	592,0	526,0	158,0	102,0
	4	-	-	211,0	123,0	298,0	210,0	384,0	269,0	471,0	383,0	558,0	470,0	224,0	136,0
	5	-	-	-	-	264,0	154,0	350,0	240,0	437,0	327,0	524,0	414,0	280,0	170,0
	6	-	-	-	-	230,0	98,0	316,0	184,0	403,0	271,0	490,0	358,0	336,0	204,0
AP 160	3	222,4	132,6	340,7	251,0	459,1	369,3	577,4	487,6	695,7	605,9	814,0	724,2	222,4	132,6
	4	-	-	296,5	176,9	414,9	295,2	533,2	413,5	651,5	531,8	769,8	650,1	296,5	176,9
	5	-	-	-	-	370,7	221,1	489,0	339,4	607,3	457,7	725,6	576,0	370,7	221,1
	6	-	-	-	-	326,5	147,0	444,8	265,3	563,1	383,6	681,4	501,9	444,8	265,3
AP 180	3	287,9	191,0	447,6	350,7	607,3	510,4	766,9	670,0	926,6	829,7	1068,0	989,1	287,9	191,0
	4	-	-	383,9	254,7	543,6	414,4	703,3	574,0	862,9	733,7	1022,3	893,1	383,9	254,7
	5	-	-	-	-	479,9	318,4	639,6	478,1	792,2	637,7	958,6	797,1	479,9	318,4
	6	-	-	-	-	416,2	222,4	575,9	382,1	735,6	541,8	894,9	701,1	575,9	382,1
AP 200	3	423,6	242,0	644,7	463,8	867,4	685,8	1089,0	907,7	1311,0	1130,0	1533,0	1351,0	423,6	242,0
	4	-	-	564,8	322,6	786,7	544,6	1008,0	766,5	1230,0	988,4	1452,0	1209,0	564,8	322,6
	5	-	-	-	-	706,0	403,4	927,9	625,3	1150,0	847,2	1372,0	1068,0	706,0	403,4
	6	-	-	-	-	625,3	262,2	847,2	484,1	1069,0	706,0	1291,0	927,0	847,2	484,1
AP 240	3	664,0	453,6	1036,6	826,2	1409,1	1198,7	1781,7	1571,2	2154,2	1943,8	2526,8	2316,3	664,0	453,6
	4	-	-	885,4	604,8	1257,9	977,4	1630,5	1349,9	2003,0	1722,5	2375,6	2095,0	885,4	604,8
	5	-	-	-	-	1106,7	756,0	1479,3	1128,6	1851,8	1501,1	2224,4	1873,7	1106,7	756,0
	6	-	-	-	-	955,5	534,7	1328,1	907,2	1700,6	1279,8	2073,2	1652,3	1328,1	907,2
AP 270	3	912,5	705,1	1451,7	1244,3	1990,9	1783,5	2530,1	2322,7	3069,3	2861,9	3608,5	3401,1	912,5	705,1
	4	-	-	1216,7	940,2	1755,9	1479,4	2295,1	2018,6	2834,3	2557,8	3373,5	3097,0	1216,6	940,1
	5	-	-	-	-	1520,9	1175,5	2060,1	1714,4	2599,3	2144,4	3138,5	2792,8	1520,8	1175,1
	6	-	-	-	-	1285,8	871,0	1825,0	1410,2	2364,2	1953,6	2903,4	2488,6	1825,0	1410,2
AP 330	3	1739,5	1193,5	2717,2	2171,1	3694,8	3148,8	4672,5	4126,4	5650,1	5104,1	6627,8	6081,8	1739,5	1193,5
	4	-	-	2319,3	1591,3	3297,0	2569,0	4274,6	3546,6	5252,3	4524,3	6230,0	5501,9	2319,3	1591,3
	5	-	-	-	-	2899,2	1989,1	3876,8	2966,8	4854,5	3944,4	5832,1	4922,1	2899,2	1989,1
	6	-	-	-	-	2501,3	1409,3	3479,0	2386,9	4456,7	3364,6	5434,3	4342,3	3479,0	2386,9

Torque output available from air supply

Torque output available from springs

0° = closed pistons, extended springs
90° = open pistons, compressed springs

 = air supply/springs balanced torques

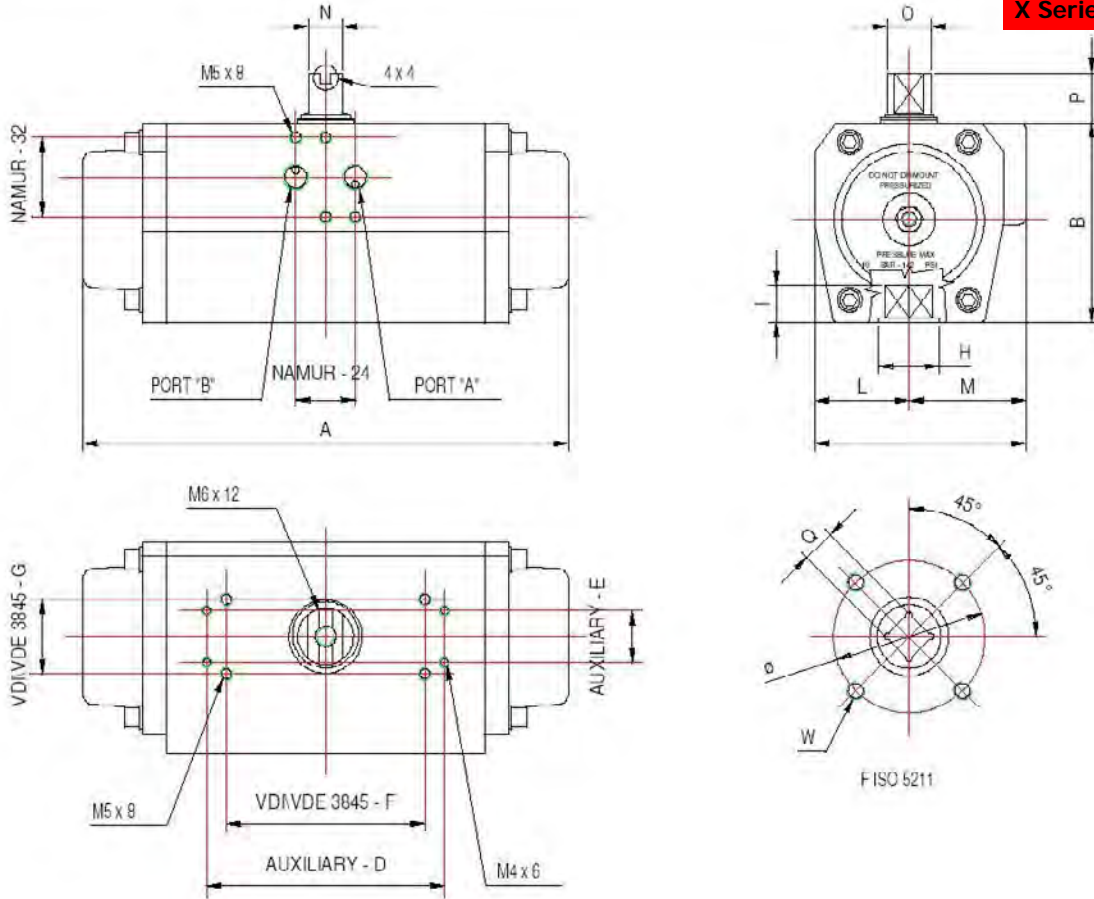

**Standard feeding connection 1/2" GAS – NPT for AP 240, 270, 330
Special NAMUR plate on request**

POSITION	TYPE																
	AP032	AP042	AP050	AP063	AP075	AP085	AP100	AP115	AP125	AP145	AP160	AP180	AP200	AP240	AP270	AP330	
A-90°	117	160	138	155,5	210	228	280,5	310	362	390	462	474	575	604	685	850	
A-120°	150	194	172	201	249	282	332	373	432	-	-	-	-	-	-	-	
A-180°	195	230	211	220	298	338	401	462	570	-	-	-	-	-	-	-	
B	45	57	67	83	100	110	125	142	155	175	196	220	240	298	332	414	
C	48	60,5	75	86	94	104	120	134	141	163	176	196	220	300	352	400	
AUXILIARY D x E	-			105 x 22				139 x 22					-				
VDI/VDE 3845 F x G	50 x 25		80 x 30					130 x 30									
L	22,5	27	33,5	38	42,5	49	55	63,5	69,5	80	88	98	110	150	166	190	
M	25,5	33,5	41,5	48	51,5	55	65	70,5	71,5	83						210	
Port A Port B DIN 259	1/8" GAS - NPT			1/4" GAS - NPT							1/2" GAS - NPT						
N x O	8 x 12			14 x 18				27 x 36				32 x 42		32 x 60		55 x 80	
P	20						30				50						
Q x I	9 x 10	9 x 10 11 x 13	9 x 10 11 x 13	9 x 10 11 x 13 14 x 16	11 x 13 14 x 16 17 x 20	14 x 16 17 x 20	17 x 20 22 x 25	17 x 20 22 x 25	17 x 20 22 x 25 27 x 30	22 x 25 27 x 30	22 x 25 27 x 30	27 x 30 36 x 39	27 x 30 36 x 39	36 x 39 46 x 50	36 x 39 46 x 50	46 x 50 55 x 60	
F ISO 5211	F03 F04	F04 F03/05	F03 F04 F03/05 F05	F04 F03/05 F05 F05/07	F04 F05/07	F05/07	F07/10 F5/7/10	F07/10	F07/10 F12	F10/12	F10/12	F10/12 F14	F10/12 F14	F14 F16	F14 F16	F16 F25	

POSITION	F ISO 5211											
	F03	F04	F03/05	F05	F05/07	F5/7/10	F07/10	F10/12	F12	F14	F16	F25
Ø (W)	36 (M5x8)	42 (M5x8)	36 (M5x8) 50 (M6x9)	50 (M6x9)	50 (M6x9) 70 (M8x12)	50 (M6x9) 70 (M8x12) 102 (M10x15)	70 (M8x12) 102 (M10x15)	102 (M10x15) 125 (M12x18)	125 (M12x18)	140 (M16x24)	165 (M20x30)	254 (M16x24)
H	25 excluded AP 032	30	25	35	35 (AP085=40)	40	55	AP145 = 70 AP160 = 75 AP180 = 85 AP200 = 85	75	100 (AP270=104)	130	200

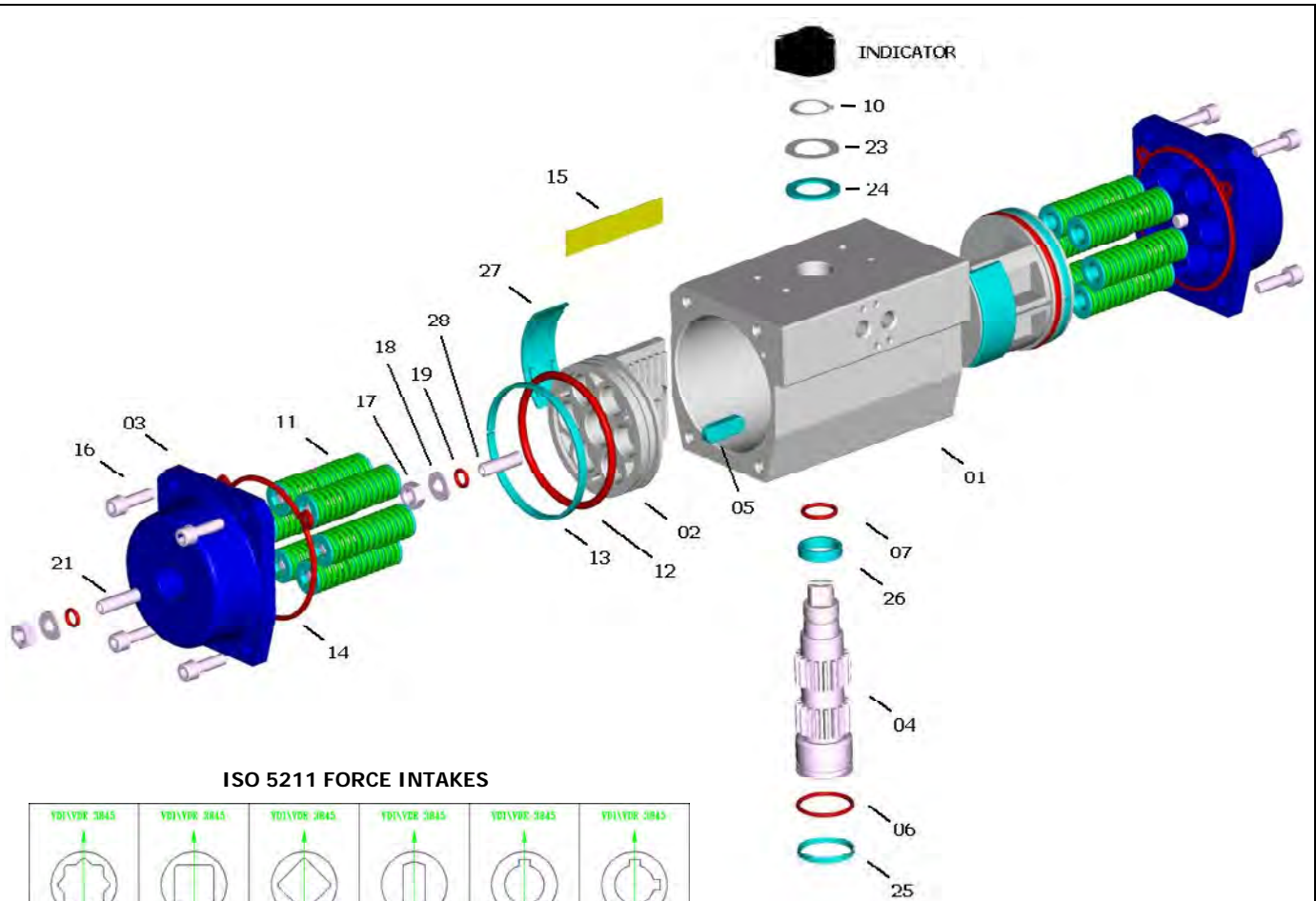





PART	QUANTITY	DESCRIPTION	MATERIAL	SPECIFICATION	PROTECTION
1	1	Body	Extruded aluminium alloy	ASTM 6063 T6	A - N - TF
2	2	Piston	Aluminium alloy	ASTM B179 - DIN1725/5	A
3	2	Cover	Aluminium alloy	ASTM B179 - DIN1725/5	N - V - TF
4	1	Shaft	Carbon steel optional S.S. AISI 316 (A4)	ASTM A105 optional S.S. AISI 316 (A4)	N
5 *	2	Antiejection key	Acetalic resin – PA66 – PA66		
6 *	1	Lower shaft O-Ring	NBR - Viton - Silicone		
7 *	1	Upper shaft O-Ring	NBR - Viton - Silicone		
10 *	1	Seeger ring	Carbon steel		N
11	0-12	Spring cartridge	Carbon steel, PA 66, S.S.	C-98	V
12 *	2	Piston O-Ring	NBR - Viton - Silicone		
13 *	2	Piston head bearing	Acetalic resin – PA66 – PA66		
14 *	2	Cover gasket	NBR - Viton - Silicone		
15	1	Nameplate	Aluminium		
16	8-16	Cover fastening screw	Stainless Steel	AISI 304 (A2)	
17	4	Nut	Stainless Steel	AISI 304 (A2)	
18	4	Washer	Stainless Steel	AISI 304 (A2)	
19 *	4	O-Ring	NBR - Viton - Silicone		
21	2	Cover dowel	Stainless Steel	AISI 304 (A2)	
23 *	1	Shaft thrust washer	Stainless Steel	AISI 304 (A2)	
24 *	1	Antifriction washer	Acetalic resin – PA66 – PA66		
25 *	1	Lower shaft pilot ring	Acetalic resin – PA66 – PA66		
26 *	1	Upper shaft pilot ring	Acetalic resin – PA66 – PA66		
27 *	2-4	Piston bearing	Acetalic resin – PA66 – PA66		
28	2	Piston dowel	Stainless Steel	AISI 304 (A2)	

* Standard NBR spare parts set - Special HIGH Temperatures VITON - Special LOW Temperatures SILICONE

Protection

A = Anodizing N = chemical Nickel-plating V = Painting TF = Anodizing+PTFE

COATINGS – MATERIAL TREATMENTS

	AV	DESCRIPTION				APPLICATION FIELD
		Body	Covers	Pistons	Shaft	
	standard	Hard Anodizing	Polyester painting	Anodizing	High phosphorous nickel-plating (12%) <i>opt. AISI 316 (A4)</i>	- Industry, general use.
	Colour	Dark gray	Several available	Brown	Polished steel	
	Thickness	50 µ	60/80 µ	15 µ	20 µ	
	NV	DESCRIPTION				APPLICATION FIELD
		Body	Covers	Pistons	Shaft	
		High phosphorous nickel-plating (12%)	Polyester painting	Anodizing	High phosphorous nickel-plating (12%) <i>opt. AISI 316 (A4)</i>	- Industry, general use. - Caustic soda. - Detergents. - Low alkaline solutions.
	Colour	Polished steel	Several available	Brown	Polished steel	
	Thickness	20 µ	60/80 µ	15 µ	20 µ	
	NN	DESCRIPTION				APPLICATION FIELD
		Body	Covers	Pistons	Shaft	
		High phosphorous nickel-plating (12%)	High phosphorous nickel-plating (12%)	Anodizing	High phosphorous nickel-plating (12%) <i>opt. AISI 316 (A4)</i>	- Industry, general use. - Caustic soda. - Detergents. - Low alkaline solutions.
	Colour	Polished steel	Polished steel	Brown	Polished steel	
	Thickness	20 µ	20 µ	15 µ	20 µ	
	TF TF	DESCRIPTION				APPLICATION FIELD
		Body	Covers	Pistons	Shaft	
		Hard Anodizing + PTFE coating	Anodizing + PTFE coating	Anodizing	High phosphorous nickel-plating (12%) <i>opt. AISI 316 (A4)</i>	- Industry, general use. - Low alkaline and low acid solutions. - Marine environments. - High temperatures.
	Colour	Blue	Blue	Brown	Polished steel	
	Thickness	Anodizing 50 µ PTFE 15 µ	Anodizing 50 µ PTFE 15 µ	15 µ	20 µ	

HARD ANODIZING

Anodizing is an electrolytic process that produces anodic coating on aluminum, called alumine, with high thickness. Alumine is one of the most hard known materials, with resistance values up to 400-600 HV (45-65 HRC); properties and features of Hard Anodizing (alumine thickness 50 micron) are well know and appreciated both for mechanical and chemical resistance.

- **Best friction and corrosion resistance, best surface hardness, good thermic and electrical insulation.**

ELECTROLESS NICKEL-PLATING

Chemical nickel-plating is an electroless coating process that gives nickel layers at extremely constant thickness also on sharp angles, blind-holes, threads and grooves recess. During the process, nickel is combined with phosphor at a percentage of 12% (high-phospor). The obtained surface hardness is about 400-480 HV (45-55 HRC).

- **Best friction and corrosion resistance, best surface hardness, best external appearance similar to S.S., increased resistance to alcali and detergents in sanitary and food applications.**

POLYESTER PAINTING

Polyester painting is obtained through powder coatings on polarized parts, by means of light differences in electrical potentials. After applications, parts are baked in order to polymerize and let the painting be spread to avoid micro-porosity. The best elasticity can be obtained at 60/80 micron thickness; a satisfactory adhesion can be assured by sandblasting or brushing, and by special degreasing baths of the rough pieces to be treated.

- **Better corrosion resistance, protection against crashes, better external appearance and several available colours, resistance to chemicals.**

HARD ANODIZING + PTFE COATING

As further improvement of the hard anodizing on aluminium alloys, protective coating made of PTFE is used, known for its particular chemical and physical features. On these double treated surfaces, oxide hardness and low roughness (internal slipping parts) is summed to the chemical resistance and the excellent qualities as a thermic barrier of PTFE (external surfaces, subjected to corrosion).

- **Best corrosion resistance, protection against high temperatures, crashes, extreme resistance to chemicals and in marine environment.**

AISI 316 (A4) STAINLESS STEEL SHAFT (OPTIONAL)

AISI 316 (A4) Stainless Steel shaft, with its great corrosion resistance, is recommended for special applications such as: marine and chemical environments, food and pharmaceutical industry, high temperature applications.



Via Molino Emili, 16 - 25030 MACLODIO (BS) Italy - Tel. +39 030 97 86 61/2 - Fax +39 030 97 86 63
www.alphair.it - www.alphapompe.it

