

**LUG BUTTERFLY VALVE INITIAL RANGE
CAST IRON BODY WITH DUCTILE IRON DISC AND EPDM SEAT**



Certificate 3.1

Size : DN 40 to DN 600
Ends : Between flanges PN10/16
Min Temperature : -15°C
Max Temperature : + 110°C (130°C C temporarily)
Max Pressure : 16 Bars up to DN300, 10 bars over
Specifications : Long neck for isolation
Ductile iron disc nickeled coated
EPDM vulcanized seat

Materials : Cast iron body

LUG BUTTERFLY VALVE INITIAL RANGE CAST IRON BODY WITH DUCTILE IRON DISC AND EPDM SEAT

SPECIFICATIONS :

- Long neck for isolation
- ISO 5211 mounting pad
- Lug type
- Between flanges PN10 or PN16 from DN 40 to DN 600
- Full crossing stem up to DN600
- 10 positions cranted lever, with locking device up to DN150
- Double PTFE gasket on stem up to DN600
- Ductile iron disc nickered coated (20-30 microns thickness)
- Epoxy painting RAL003 80 microns thickness
- EPDM vulcanized seat

USE :

- Cold and hot water
- Min and max Temperature Ts : - 15°C to + 110°C (130°C temporarily)
- Max Pressure Ps : 16 bars up to DN300, 10 bars over
- For temporary using, can be used at the end of the pipe (6 bars maxi)

FLOW COEFFICIENT Kv (M3 / h) :

DN	40	50	65	80	100	125	150	200	250	300	350	400	450	500	600	
Opening angle	10°	0,04	0,05	0,09	0,17	0,26	0,43	0,68	1,7	2,6	3,4	5,1	6,8	9,4	11,9	18,8
	20°	2	3	5	8	15	25	38	76	129	200	288	396	525	675	1042
	30°	5	6	10	15	31	52	81	160	273	422	610	839	1101	1428	2207
	40°	10	13	21	33	67	113	175	348	592	914	1321	1817	2407	3095	4781
	50°	18	23	38	60	119	202	312	620	1055	1630	2355	3239	4289	5515	8521
	60°	30	38	64	99	196	334	516	1025	1746	2697	3897	5359	7097	9125	14098
	70°	48	60	102	156	310	529	817	1623	2764	4269	6167	8481	11232	14442	22312
	80°	72	90	152	235	466	793	1226	2434	4145	6403	9250	12720	16848	21662	33468
	90°	78	98	167	258	512	872	1347	2675	4555	7037	10165	13799	18514	23805	36778

TORQUE VALUES (Nm, without safety coefficient) :

We recommend a safety coefficient of 30% minimum to determinate the actuator.

DN	40	50	65	80	100	125	150	200	250	300	350	400	450	500	600
PN10	11	15	24	31	48	73	106	177	281	410	475	746	1112	1356	2468
PN16	12	16	26	33	53	81	119	194	308	441	-	-	-	-	-

**LUG BUTTERFLY VALVE INITIAL RANGE
CAST IRON BODY WITH DUCTILE IRON DISC AND EPDM SEAT**

PRESSURE / TEMPERATURE GRAPH (STEAM EXCLUDED) :

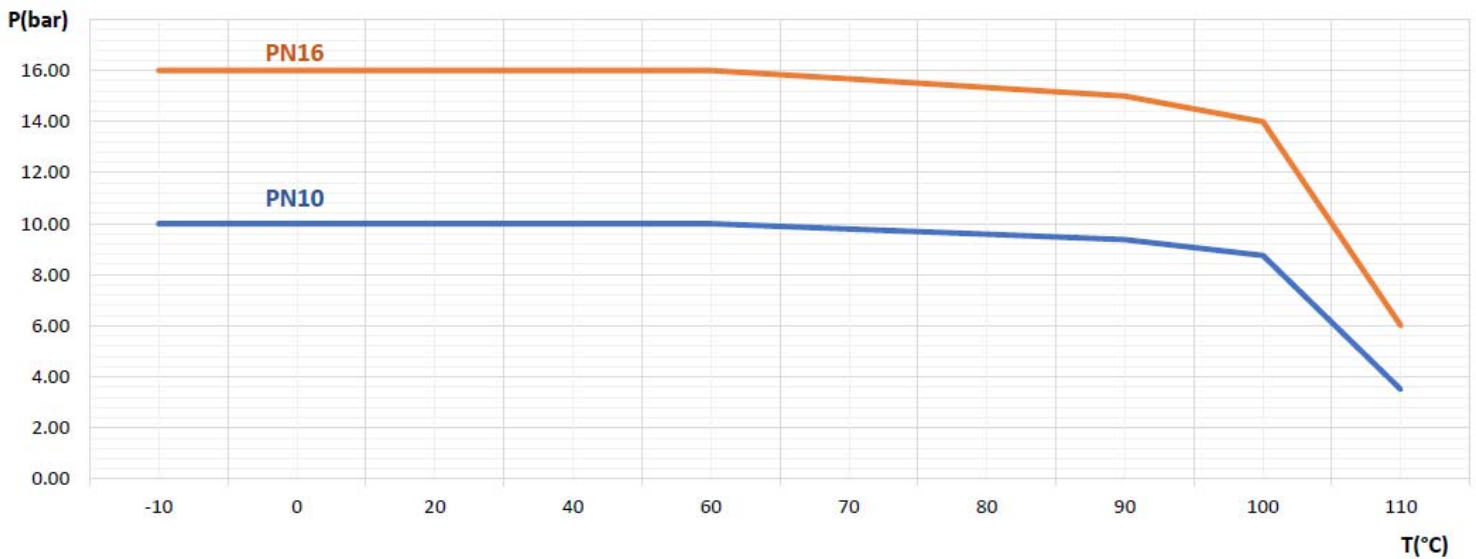

RANGE :

- With lever from DN40 to DN300
- With gearbox from DN350 to DN600
- Gearbox possible from DN40 to DN300 **Ref.1198**

**LUG BUTTERFLY VALVE INITIAL RANGE
CAST IRON BODY WITH DUCTILE IRON DISC AND EPDM SEAT**

MATERIALS DN 40 – 300 :

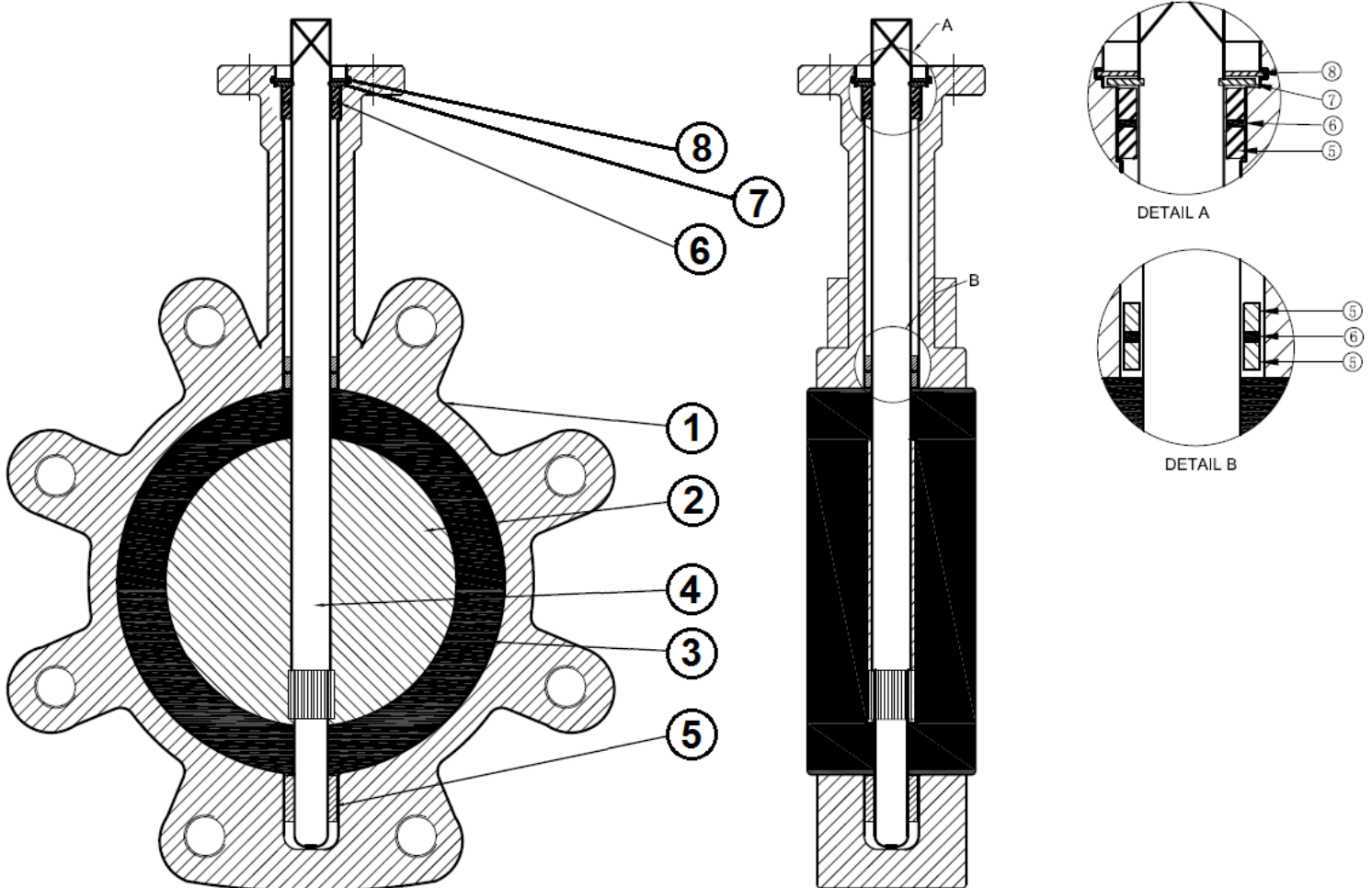

Item	Designation	Materials
1	Body	Cast iron EN GJL-250
2	Disc	Ductile iron EN GJS-400-15 nickeled coated
3	Seat	EPDM
4	Stem	AISI 416
5	Bearing	PTFE
6	O ring	EPDM
7	Circlip	Steel
8	Circlip	Steel
	Lever	Aluminium

**LUG BUTTERFLY VALVE INITIAL RANGE
CAST IRON BODY WITH DUCTILE IRON DISC AND EPDM SEAT**

MATERIALS DN 350 :

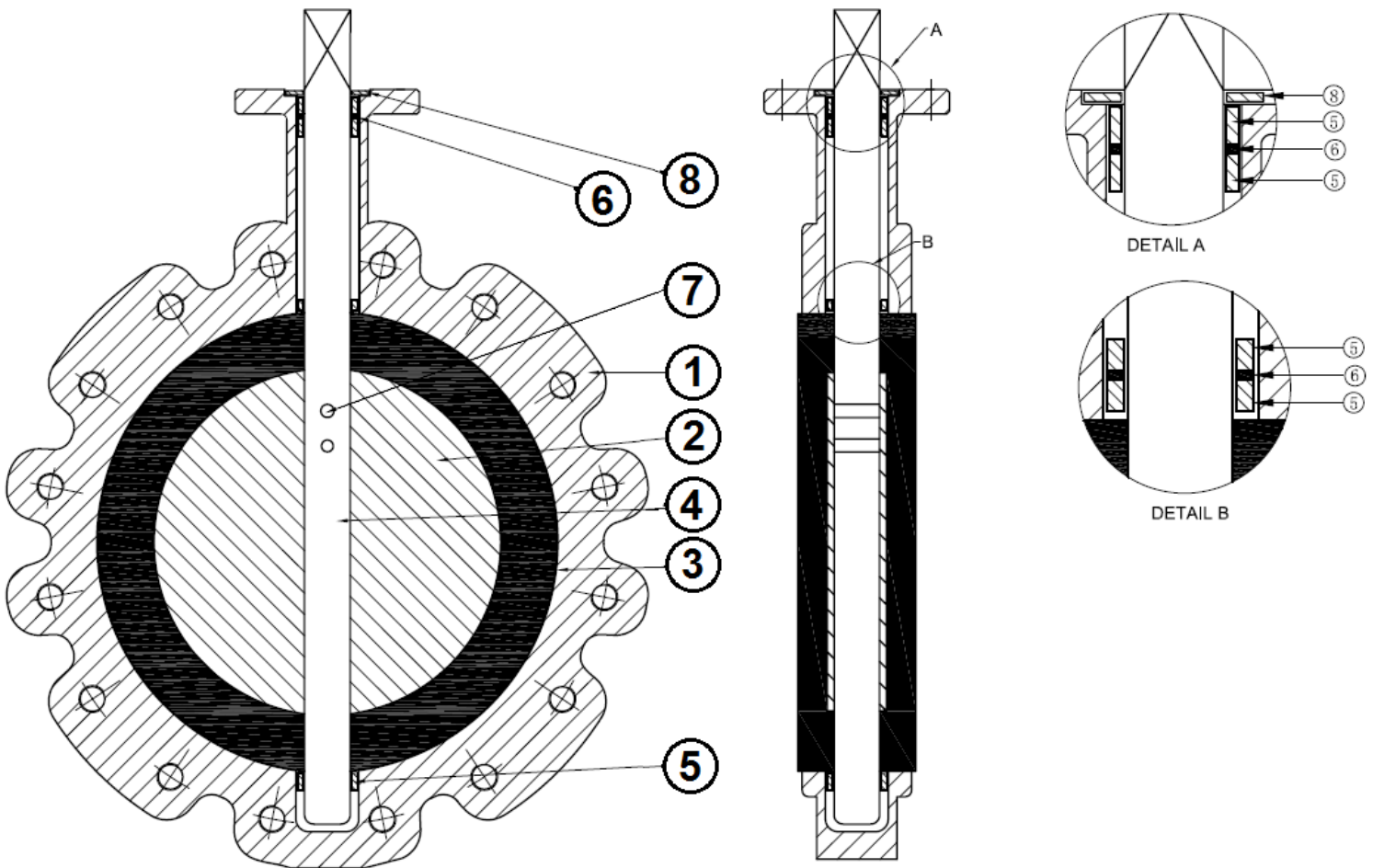

Item	Designation	Materials
1	Body	Cast iron EN GJL-250
2	Disc	Ductile iron EN GJS-400-15 nickeled coated
3	Seat	EPDM
4	Stem	AISI 431
5	Bearing	PTFE
6	O ring	EPDM
7	Pin	AISI 316
8	Gasket	EPDM

**LUG BUTTERFLY VALVE INITIAL RANGE
CAST IRON BODY WITH DUCTILE IRON DISC AND EPDM SEAT**

MATERIALS DN 400-600 :

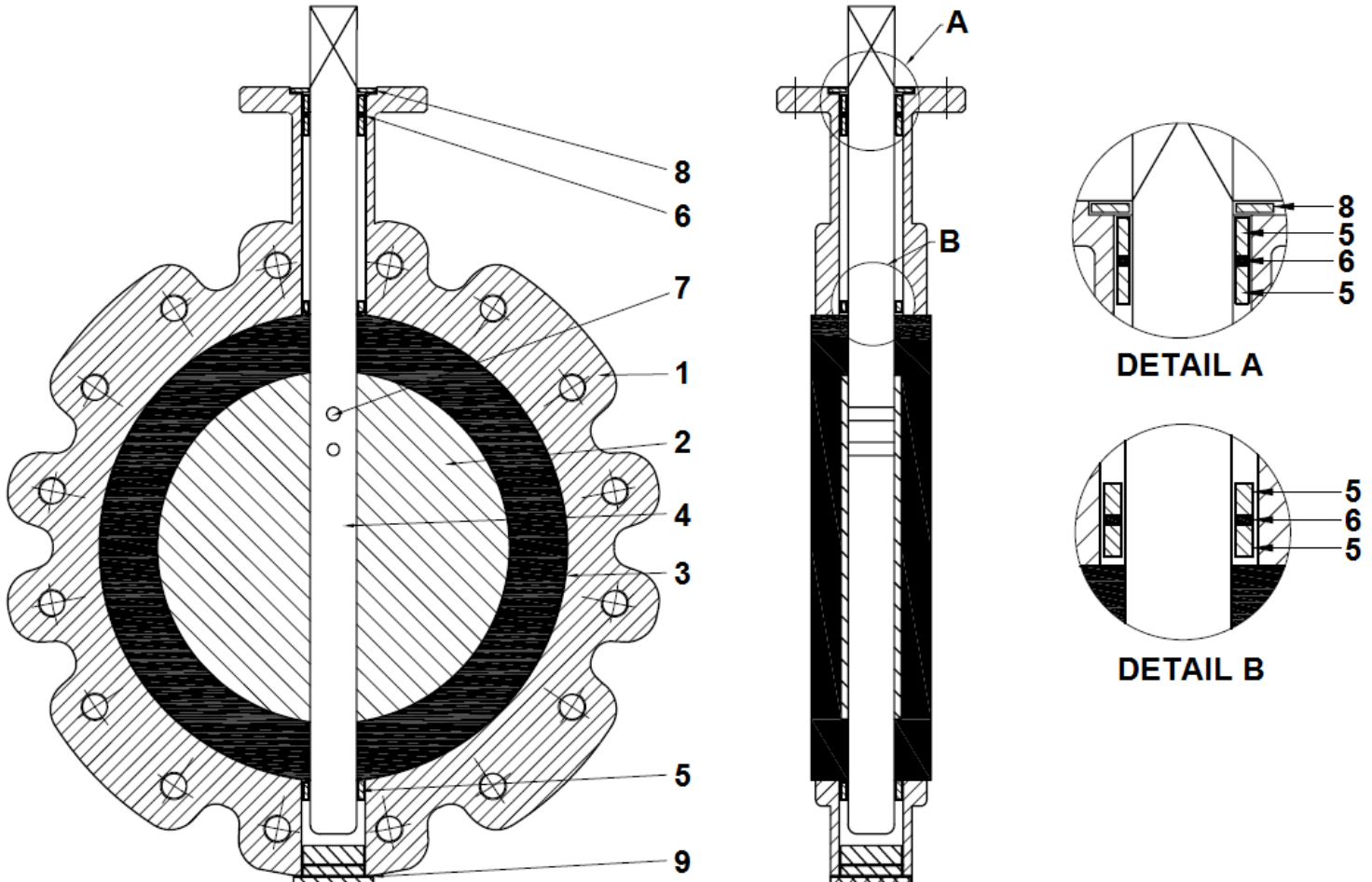

Item	Designation	Materials
1	Body	Cast iron EN GJL-250
2	Disc	Ductile iron EN GJS-400-15 nickeled coated
3	Seat	EPDM
4	Stem	AISI 431
5	Bushing	PTFE
6	O ring	EPDM
7	Pin	AISI 316
8	Gasket	EPDM
9	Gasket	EPDM

**LUG BUTTERFLY VALVE INITIAL RANGE
CAST IRON BODY WITH DUCTILE IRON DISC AND EPDM SEAT**

MATERIALS GEARBOX DN40-450 :

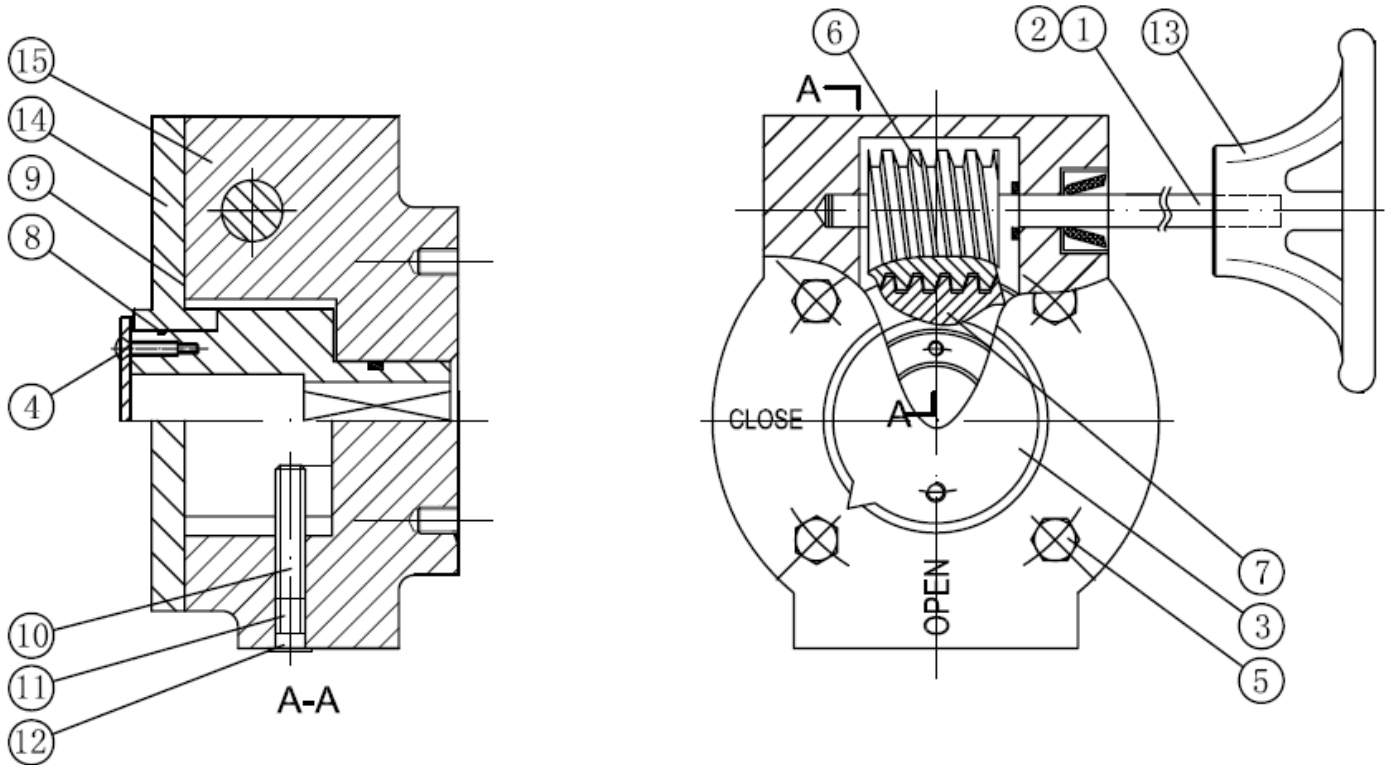

Item	Designation	Materials
1	Stem	Chromed steel
2	Pin	AISI 316
3	Indicator plate	Aluminium + NBR gasket
4	Indicator bolt, washer	AISI 316
5	Bolt, washer	AISI 316
6	Gear 1	Steel
7	Gear 2	Ductile iron EN GJS-400-15
8	O ring	NBR
9	Bonnet gasket	NBR
10	Internal set screw	Carbon steel
11	External set screw	AISI 316
12	Plastic cap	Plastic
13	Handwheel	Cast iron EN GJL-250 epoxy coating
14	Bonnet	Cast iron EN GJL-250 epoxy coating
15	Body	Cast iron EN GJL-250 epoxy coating
	Bolting to fix on valve	AISI 304

**LUG BUTTERFLY VALVE INITIAL RANGE
CAST IRON BODY WITH DUCTILE IRON DISC AND EPDM SEAT**

MATERIALS GEARBOX DN500-600 :

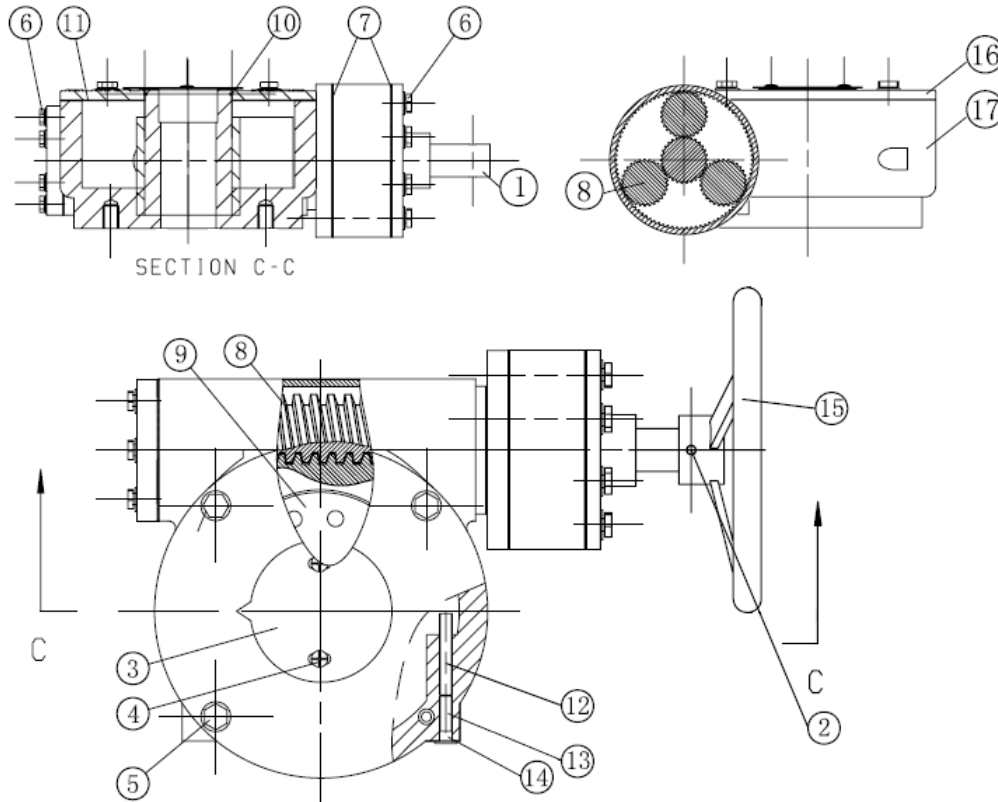

Item	Designation	Materials
1	Stem	Chromed steel
2	Pin	AISI 316
3	Indicator plate	Aluminium + NBR gasket
4	Indicator bolt, washer	AISI 316
5	Bolt, washer	AISI 316
6	Bolting	AISI 316
7	Body gasket	NBR
8	Gear 1	Steel
9	Gear 2	Ductile iron EN GJS-400-15
10	O ring	NBR
11	Bonnet gasket	NBR
12	Internal set screw	Carbon steel
13	External set screw	AISI 316
14	Plastic cap	Plastic
15	Handwheel	Cast iron EN GJL-250 epoxy coating
16	Bonnet	Cast iron EN GJL-250 epoxy coating
17	Body	Cast iron EN GJL-250 epoxy coating
	Bolting to fix on valve	AISI 304

**LUG BUTTERFLY VALVE INITIAL RANGE
CAST IRON BODY WITH DUCTILE IRON DISC AND EPDM SEAT**

VALVES WITH LEVER SIZE DN 40 – 300 (in mm) :

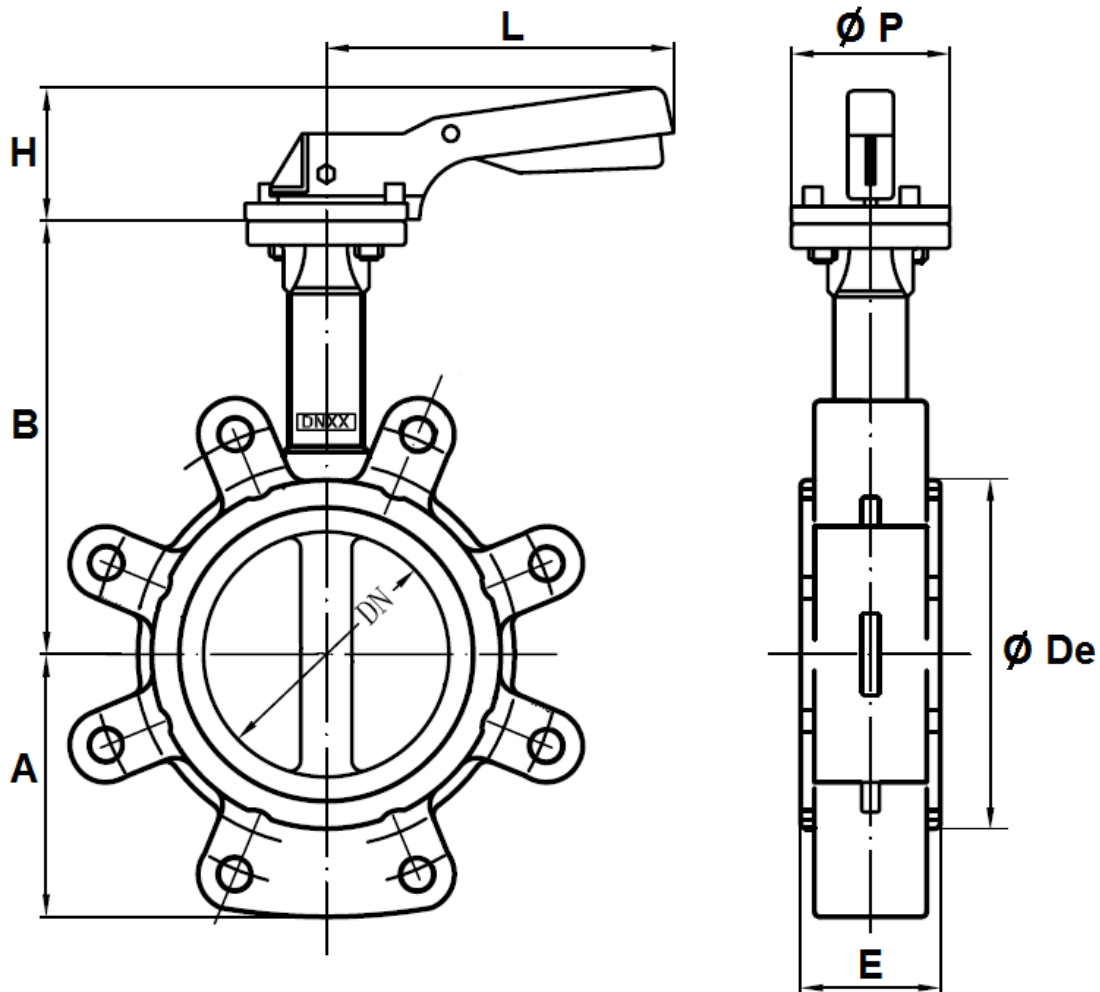

Ref.	DN	40	50	65	80	100	125	150	200	250	300
1135	A	61	77	88	95	107	122	144	171	205	235
	B	130	137	142	158	180	192	215	242	280	310
	Ø De	82	95	109	127	152	180	207	260	315	370
	E	33	43	46	46	52	56	56	60	68	78
	H	70	70	70	70	70	71	71	40	44	44
	L	195	195	195	195	195	278	278	355	507	507
	Ø P	65	65	65	65	65	90	90	125	150	150
	Weig. (Kg)	2.43	3.13	3.73	4.98	5.64	9.06	10.96	16.67	31.4	42

**LUG BUTTERFLY VALVE INITIAL RANGE
CAST IRON BODY WITH DUCTILE IRON DISC AND EPDM SEAT**

VALVES WITH GEARBOX SIZE DN 350 (in mm) :

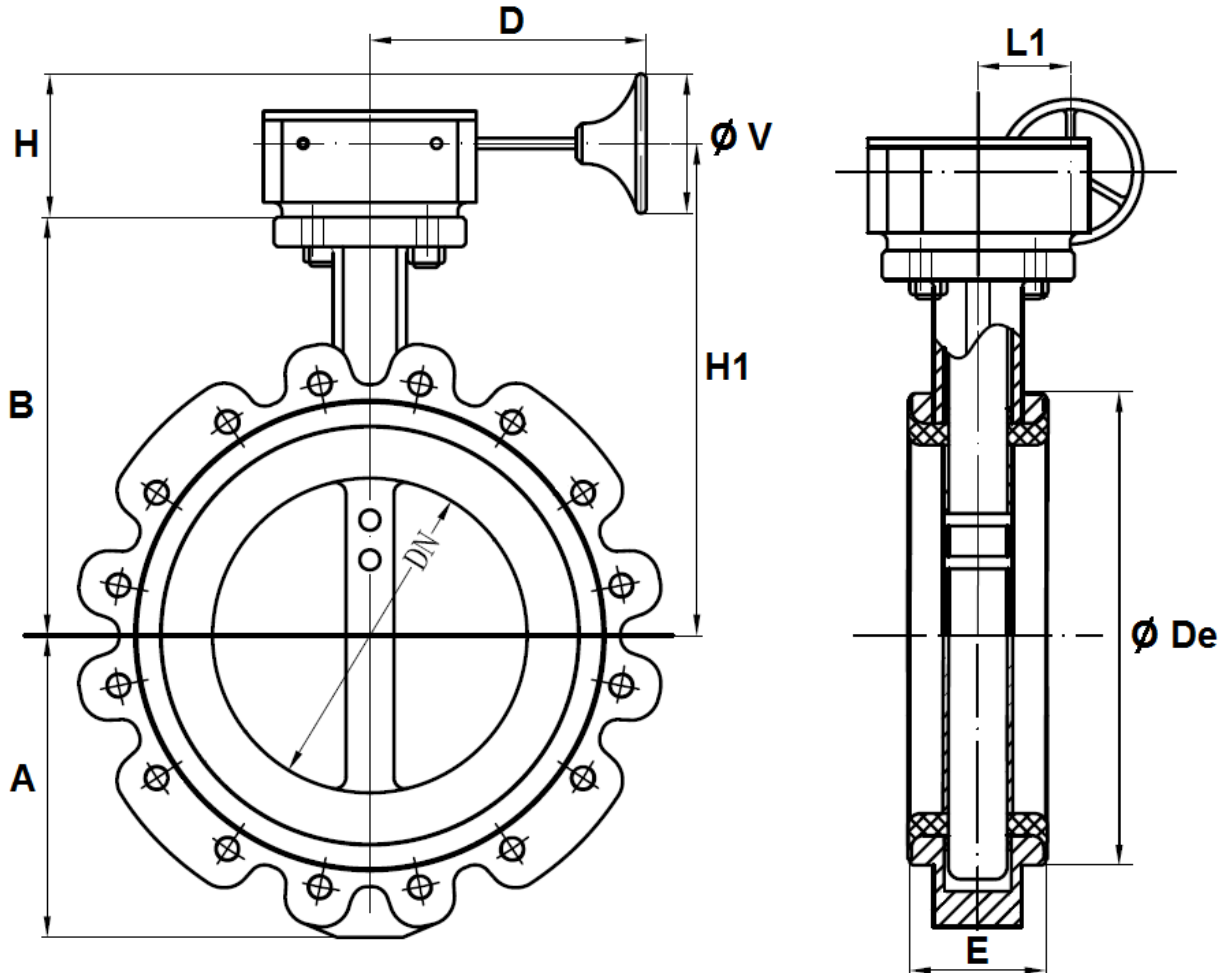

Ref.	DN	350
1135	A	266
	B	367
	D	223
	Ø De	418
	E	78
	H	190
	H1	412
	L1	78
	Ø V	300
	Weight (Kg)	75.9

**LUG BUTTERFLY VALVE INITIAL RANGE
CAST IRON BODY WITH DUCTILE IRON DISC AND EPDM SEAT**

SIZE VALVES WITH GEARBOX DN 400-600 (in mm) :

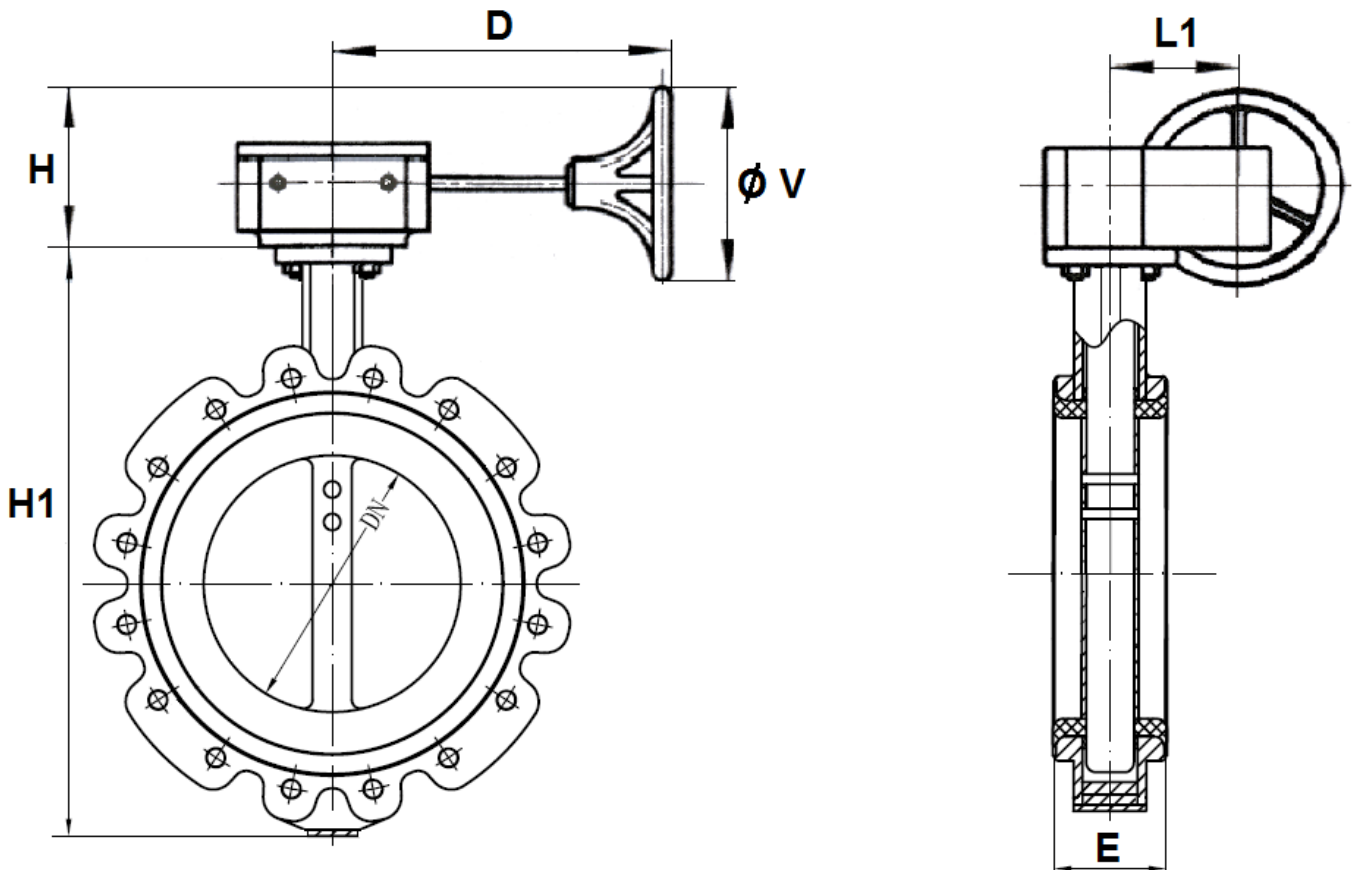

Ref.	DN	400	450	500	600
1135	A	324	341	374	478
	B	394	419	474	565
	D	270	270	339	339
	Ø De	470	525	570	697
	E	102	114	127	154
	H	208	258	222	222
	H1	456	481	539	630
	L1	120	120	120	120
	Ø V	400	400	300	300
	Weight (Kg)		115.5	147	202.8

**LUG BUTTERFLY VALVE INITIAL RANGE
CAST IRON BODY WITH DUCTILE IRON DISC AND EPDM SEAT**

SIZE GEARBOX DN40-300 (in mm) :

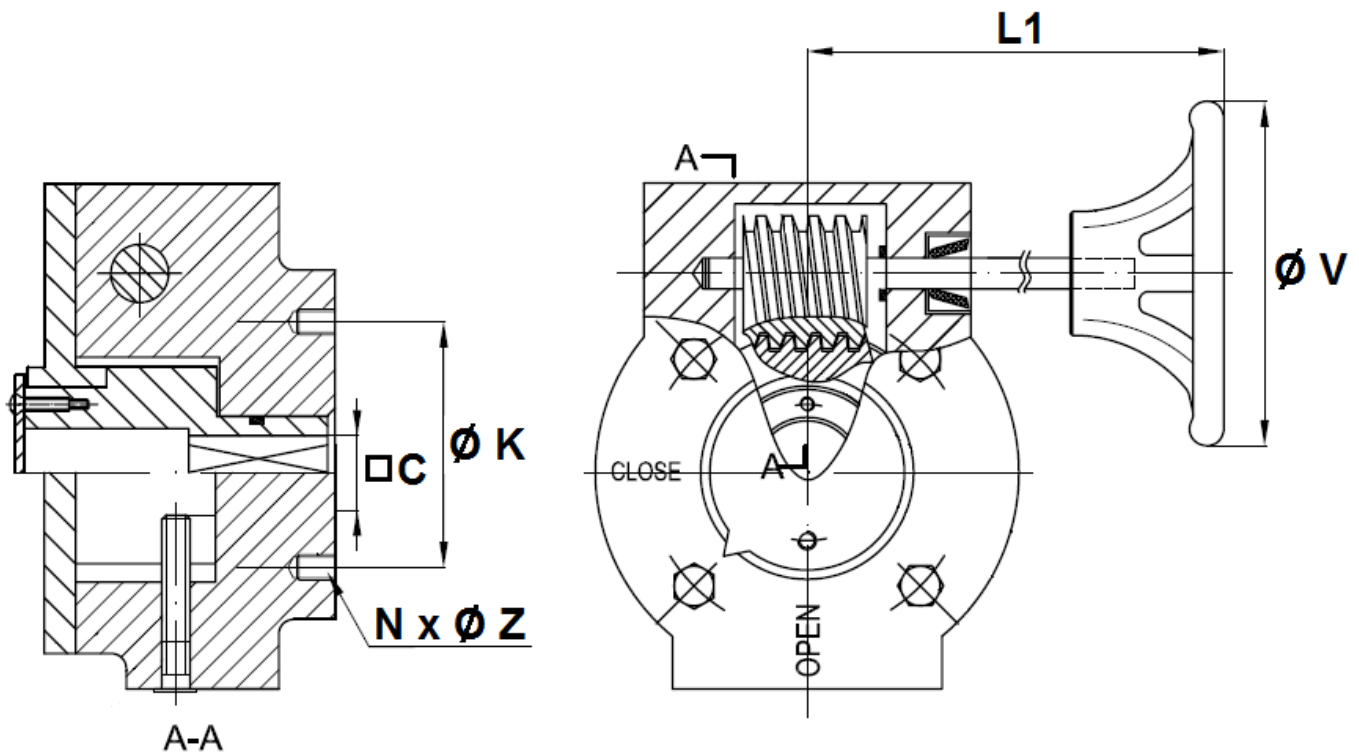

DN	40/80	100	125/150	200	250	300
C	9	11	14	17	22	27
Ø K	50	50	70	102	125	125
ISO	F05	F05	F07	F10	F12	F12
Nx ØZ	4 x M6	4 x M6	4 x M8	4 x M10	4 x M12	4 x M12
L1	156	156	156	241	223	223
Ø V	145	145	245	295	295	295
Weight (kg)	3.51	4.22	3.53	6.99	7.42	9.6
Ref.	1198001	1198002	1198003	1198004	1198005	1198006

**LUG BUTTERFLY VALVE INITIAL RANGE
CAST IRON BODY WITH DUCTILE IRON DISC AND EPDM SEAT**

DISC AND NECK SIZE (in mm) :

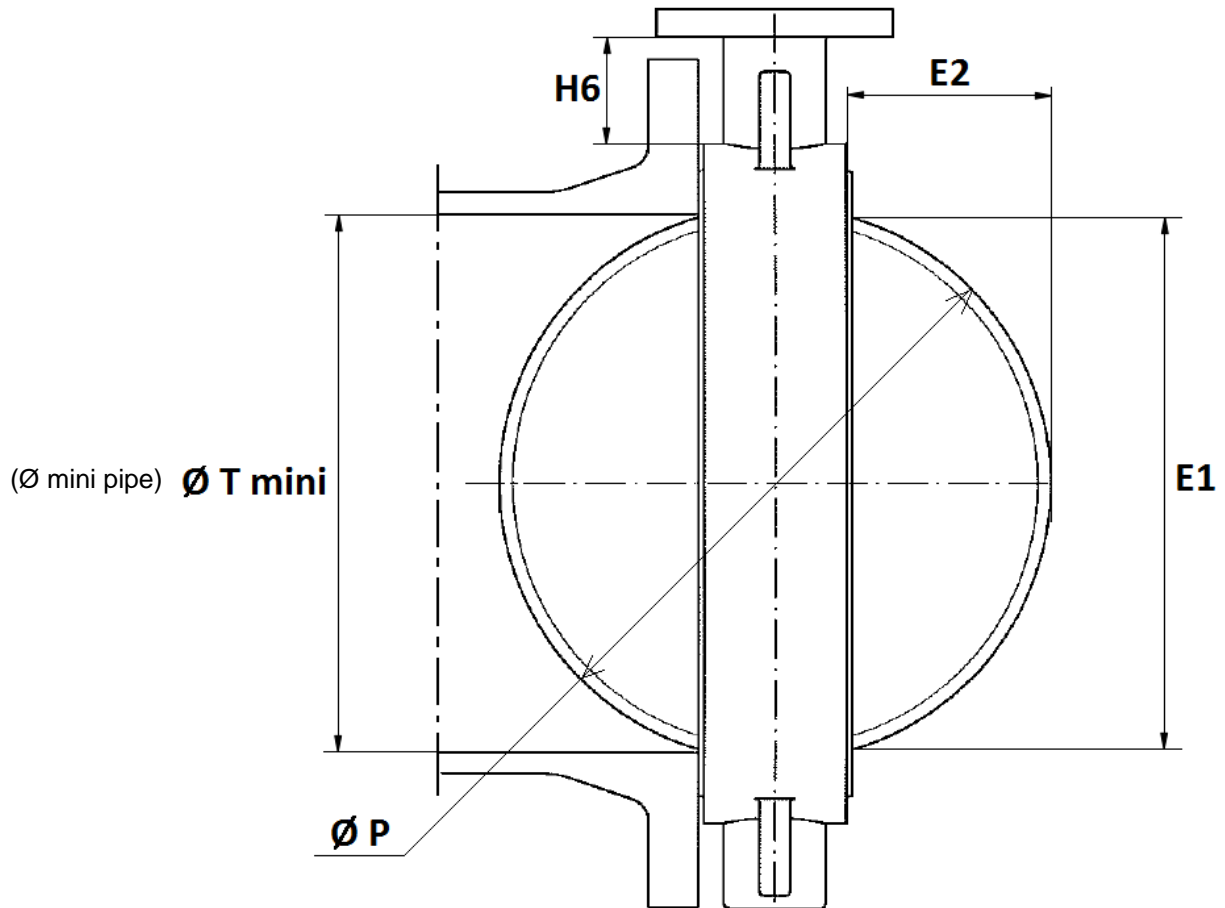

DN	40	50	65	80	100	125	150	200	250	300	350	400	450	500	600
E1	37.7	47.06	59.81	75.56	98.37	117.02	147.65	195.3	242.5	292.6	325.4	379.8	429	480.2	580.5
E2	4.9	5	9.4	16.5	26.1	33.9	49.7	71.2	91.2	111.8	127.8	143.9	163.3	182.3	219.3
H6 ±2	76.7	79	79	87.5	92.3	90.3	99.2	99.5	103.8	105.8	105.8	109.5	113	172	192
Ø P	42.8	53	64.8	79.1	104.25	123.8	155.4	202.4	250.5	301.6	333.7	389.8	440.7	491.8	592.7
Ø T mini	43	53	65	79.5	104.5	124	155.5	202.5	250.5	302	334	390	441	492	593

**LUG BUTTERFLY VALVE INITIAL RANGE
CAST IRON BODY WITH DUCTILE IRON DISC AND EPDM SEAT**

ISO 5211 MOUNTING PAD (in mm) :

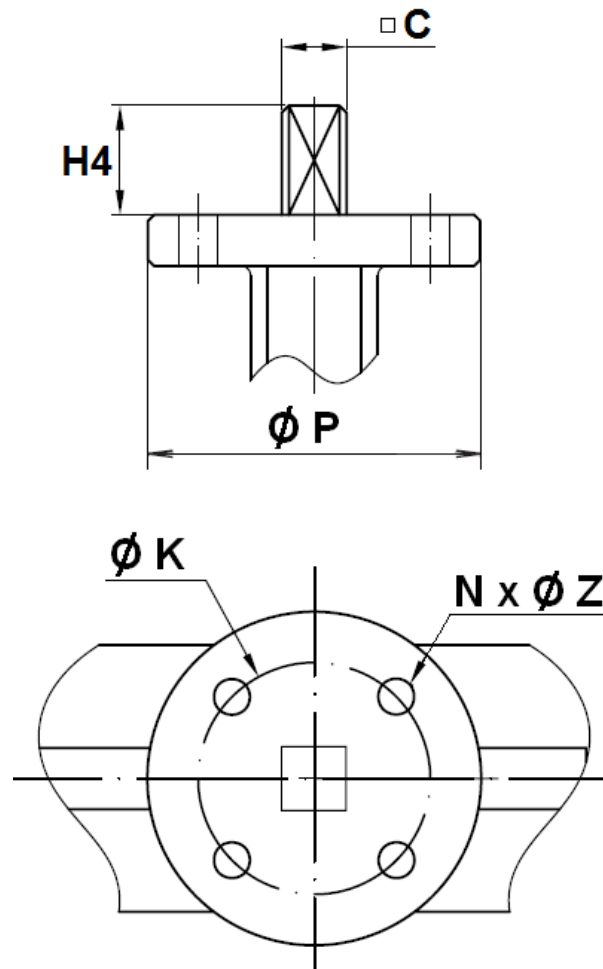

DN	40	50	65	80	100	125	150	200	250	300	350	400	450	500	600
C	9	9	9	9	11	14	14	17	22	27	27	27	30	36	46
Ø K	50	50	50	50	50	70	70	102	125	125	125	125	165	165	165
ISO	F05	F05	F05	F05	F05	F07	F07	F10	F12	F12	F12	F12	F16	F16	F16
Nx ØZ	4 x 7	4 x 7	4 x 7	4 x 7	4 x 7	4 x 9	4 x 9	4 x 11	4 x 13	4 x 13	4 x 14	4 x 14	4 x 22	4 x 22	4 x 22
H4	32	32	32	32	32	42	42	36	38	38	45	50	50	65	70
Ø P	65	65	65	65	65	90	90	125	150	150	150	150	210	210	300

**LUG BUTTERFLY VALVE INITIAL RANGE
CAST IRON BODY WITH DUCTILE IRON DISC AND EPDM SEAT**

FLANGES LUG SIZE PN10/16 (in mm) :

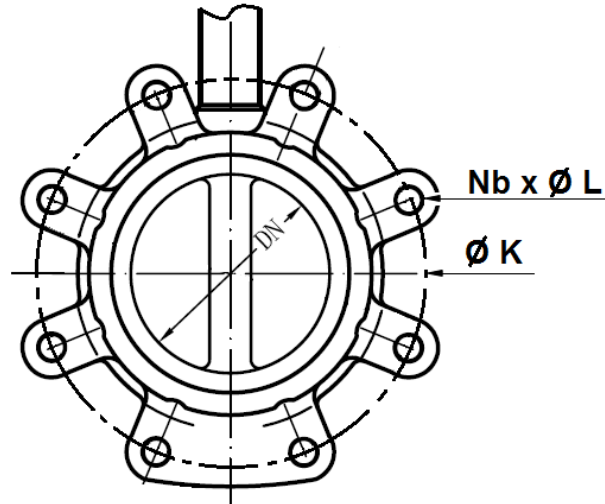

DN	40	50	65	80	100	125	150
Ø K	110	125	145	160	180	210	240
Nb x ØL	4 x M16	4 x M16	4 x M16	8 x M16	8 x M16	8 x M16	8 x M20
Ref.	1135040	1135050	1135065	1135080	1135100 and 1135102	1135125 and 1135127	1135150 and 1135152

FLANGES LUG SIZE PN10 (in mm) :

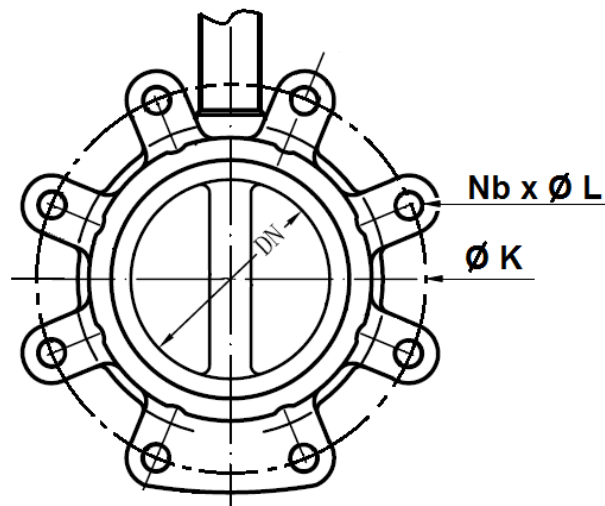

DN	200	250	300	350	400	450	500	600
Ø K	295	350	400	460	515	565	620	725
Nb x ØL	8 x M20	12 x M20	12 x M20	16 x M20	16 x M24	20 x M24	20 x M24	20 x M27
Ref.	1135200 and 1135202	1135250 and 1135252	1135300 and 1135302	1135350	1135400	1135450	1135500	1135600

**LUG BUTTERFLY VALVE INITIAL RANGE
CAST IRON BODY WITH DUCTILE IRON DISC AND EPDM SEAT**

FLANGES LUG SIZE PN16 (in mm) :

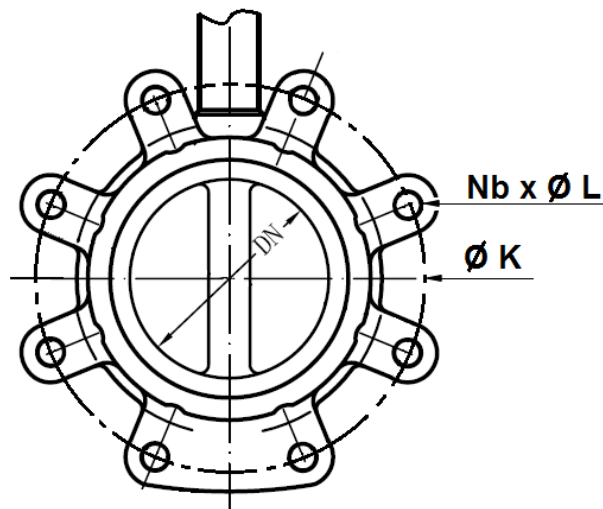

DN	200	250	300	350	400	450	500	600
Ø K	295	355	410	470	525	585	650	770
Nb x ØL	12 x M20	12 x M24	12 x M24	16 x M24	16 x M27	20 x M27	20 x M30	20 x M33
Ref.	1135201 and 1135203	1135251 and 1135253	1135301 and 1135303	1135351	1135401	1135451	1135501	1135601

**LUG BUTTERFLY VALVE INITIAL RANGE
 CAST IRON BODY WITH DUCTILE IRON DISC AND EPDM SEAT**

GEARBOX SPECIFICATIONS :

DN	32/80	100	125/150	200	250	300
Ref.	1198001	1198002	1198003	1198004	1198005	1198006
Ratio factor	24 :1	24 :1	24 :1	30 :1	30 :1	50 :1
Input torque (Nm)	18	18	18	58	58	60
Output torque (Nm)	170	170	170	700	700	1200

DN	350	400	450	500	600
Ratio factor	50 :1	80 :1	80 :1	260 :1	300 :1
Input torque (Nm)	60	78	78	30	45
Output torque (Nm)	1200	2500	2500	2500	4000

STANDARDS :

- Fabrication according to ISO 9001 :2015
- Designing according to API 609
- DIRECTIVE 2014/68/EU : CE N° 0035
Risk category III module H
- Certificate 3.1 on request
- Pressure tests according to API 598, table 6
- Length according to ISO 5752 series 20, EN 558 series 20 (NF 29305)
- ISO 5211 mounting pad
- Between flanges according to EN 1092-1 PN10/16

ADVICE : Our opinion and our advice are not guaranteed and SFERACO shall not be liable for the consequences of damages. The customer must check the right choice of the products with the real service conditions.

**LUG BUTTERFLY VALVE INITIAL RANGE
CAST IRON BODY WITH DUCTILE IRON DISC AND EPDM SEAT**

INSTALLATION INSTRUCTIONS

GENERAL GUIDELINES :

- Ensure that the valves to be used are appropriate for the conditions of the installation (type of fluid, pressure and temperature).
- Be sure to have enough valves to be able to isolate the sections of piping as well as the appropriate equipment for maintenance and repair.
- Ensure that the valves to be installed are of correct strength to be able to support the capacity of their usage.
- **Installation of all circuits should ensure that their function can be automatically tested on a regular basis (at least two times a year).**

INSTALLATION INSTRUCTIONS :

- **Before installing the valves, clean and remove any objects from the pipes** (in particular bits of sealing and metal) which could obstruct and block the valves.
- **Ensure that both connecting pipes either side of the valve (upstream and downstream) are aligned (if they're not, the valves may not work correctly).**
- **Make sure that the two sections of the pipe (upstream and downstream) match, the valve unit will not absorb any gaps. Any distortions in the pipes may affect the tightness of the connection, the working of the valve and can even cause a rupture.** To be sure, place the kit in position to ensure the assembling will work.
- **If sections of piping do not have their final support in place, they should be temporarily fixed. This is to avoid unnecessary strain on the valve.**
- The valve must be inserted between flanges with disc half opened but the disc must not overpass the valve thickness. Position the bolts to keep centered the valve. Then open fully the valve and tighten the bolts. **See graph under.**

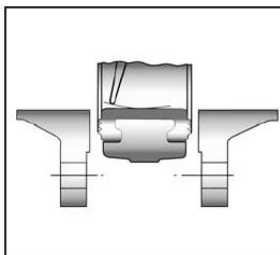

Half open valve introduction

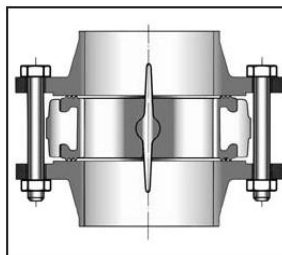

**Complete opened disc valves
when screw tightening**

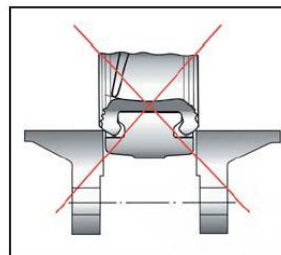

- Tighten the bolts in cross.
- The disc must move easily inside the pipe.
- Valves must be opened during cleaning operation.
- Tests must be done with a cleaned pipe.
- Tests must be done with opened valve. Test pressure must not be higher than the valve specification according to API 598.
- Then open slowly the valve.
- **Do not mount butterfly valves with stainless steel pressed collars and turning flanges without strias.**
- **And not on flat face flanges without strias (example : painted cast iron fittings)**



**LUG BUTTERFLY VALVE INITIAL RANGE
CAST IRON BODY WITH DUCTILE IRON DISC AND EPDM SEAT**

MAINTENANCE :

- We recommend to operate fully the valve 1 to 2 times per year.
- During maintenance operation, ensure that the pipe isn't under pressure, that there's no fluid in the pipe and that the valve is isolated. If there's a fluid in the pipe , evacuate it. Ensure that there are no risks due to the temperature or the fluid (like acids). If the fluid is corrosive , inert the installation before maintenance operation.