

DUCTILE IRON GATE VALVE PN16 WITH RISING STEM



Lloyd's
Register
PED/2014/68/EU



Certificate 3.1

Size : DN 40 to DN 300
Ends : Flanges PN16 R.F.
Min Temperature : - 10°C
Max Temperature : + 120°C
Max Pressure : 16 Bars
Specifications : Rising stem
Stainless steel stem
Brass seat

Materials : Ductile iron body EN GJS 500-7

DUCTILE IRON GATE VALVE PN16 WITH RISING STEM

SPECIFICATIONS :

- Single solid wedge
- Graphite packing
- Rising stem
- Stainless steel stem
- Brass seat
- Flanges R.F. PN16
- Painting RAL 7011 grey color, 90 µm thickness

USE :

- For water, water treatment, heating
- Min and max Temperature Ts : - 10°C to + 120°C
- Max Pressure Ps : 16 bars

RANGE :

- Ductile iron body flanged R.F. PN16 **Ref. 156** from DN 40 to DN 300

TORQUE VALUES (Nm without safety coefficient) :

DN	40	50	65	80	100	125	150	200	250	300
Torque (Nm)	55	55	55	60	85	115	125	135	192	192

LEAKAGE RATE (WITH WATER AT 20°C) :

DN	Leakage rate (ml/s)
40	0.024
50	0.03
65	0.039
80	0.048
100	0.06
125	0.075
150	0.09
200	0.12
250	0.15
300	0.18

NUMBER OF CYCLES TO CLOSE OR OPEN THE VALVE :

DN	40	50	65	80	100	125	150	200	250	300
Number of cycles	13	15.5	19.3	23.5	29	35.3	33.3	43.6	53.6	65

DUCTILE IRON GATE VALVE PN16 WITH RISING STEM

MATERIALS :

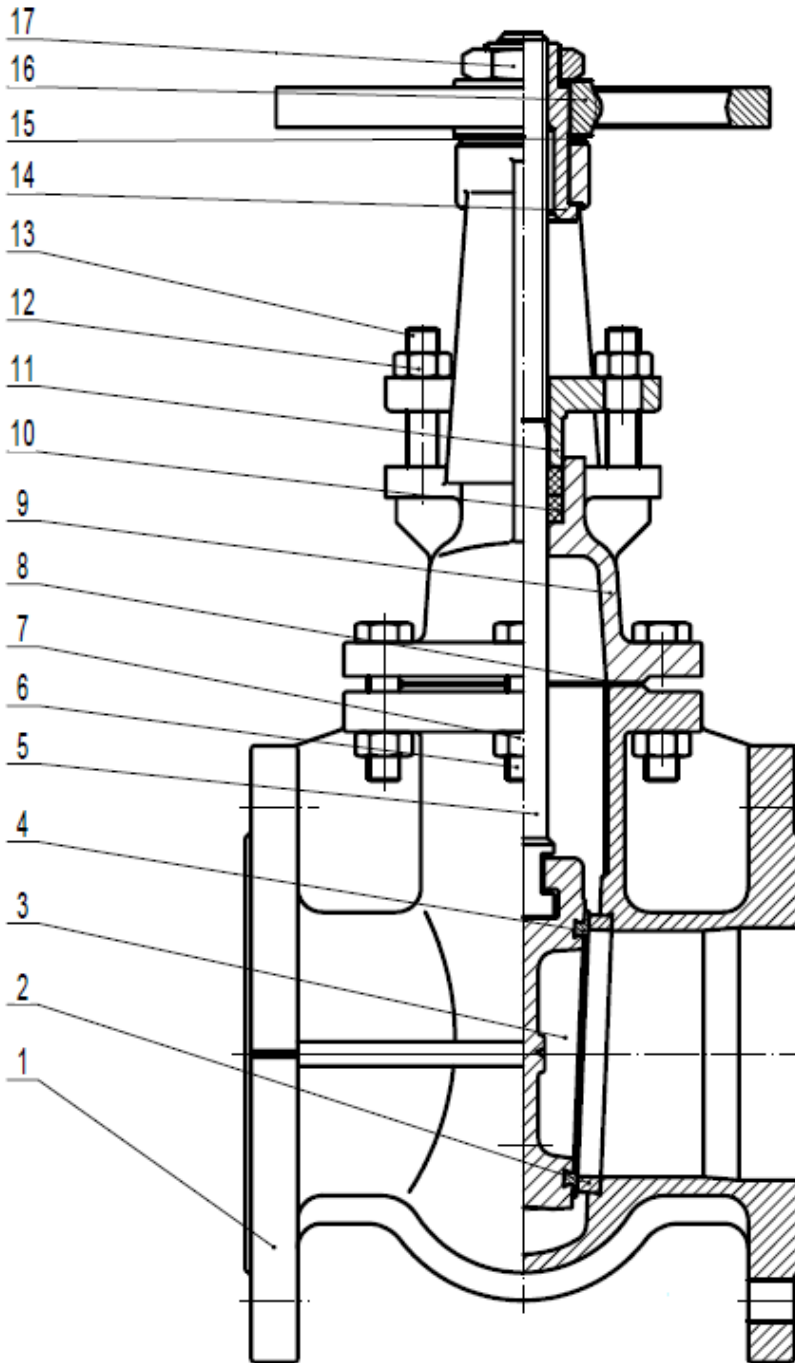

Item	Designation	Materials
1	Body	Ductile iron EN-GJS-500-7
2	Body seat	Brass
3	Wedge	Ductile iron EN-GJS-500-7
4	Wedge seat	Brass
5	Stem	AISI 420
6	Screw	Steel RSt37-2 (1.0038)
7	Nut	Steel RSt37-2 (1.0038)
8	Bonnet gasket	Graphite
9	Bonnet	Ductile iron EN-GJS-500-7
10	Packing	Graphite
11	Packing gland	Ductile iron EN-GJS-500-7
12	Nut	Steel RSt37-2 (1.0038)
13	Screw	Steel RSt37-2 (1.0038)
14	Stem nut	Brass
15	Washer	Brass
16	Handwheel	Cast iron EN GJL-250
17	Handwheel nut	Ductile iron EN GJS-500-7

DUCTILE IRON GATE VALVE PN16 WITH RISING STEM

SIZE (in mm) :

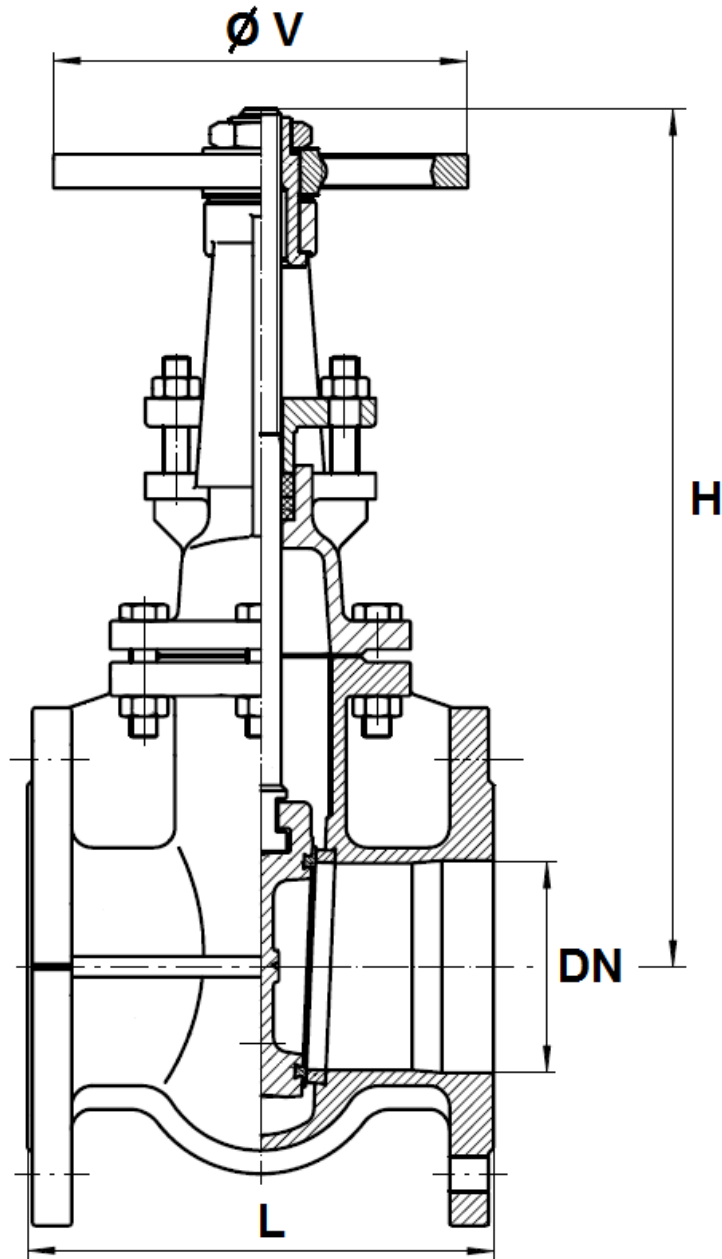

Ref.	DN	40	50	65	80	100	125	150	200	250	300
156	L	140	150	170	180	190	200	210	230	250	270
	H (closed)	244	254	294	331	385	457	545	683	823	952
	H (opened)	295	315	371	424	500	598	711	901	1093	1273
	Ø V	160	160	160	160	200	200	250	250	320	320
	Weight (Kg)	9.8	11.9	13.3	17.2	23.2	34.2	44.4	67.5	110	155

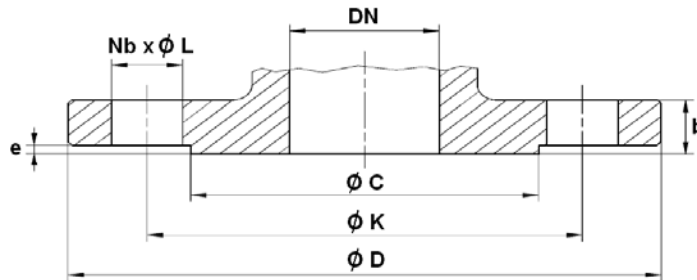
DUCTILE IRON GATE VALVE PN16 WITH RISING STEM
FLANGES SIZE (in mm) :

Ref.	DN	40	50	65	80	100	125	150	200	250	300	
156	Ø C	80	102	124	140	158	188	212	268	320	378	
	Ø D	150	165	185	200	220	250	285	340	405	460	
	Ø K	110	125	145	160	180	210	240	295	355	410	
	Nb x Ø L	4 x 19	4 x 19	4 x 19	8 x 19	8 x 19	8 x 19	8 x 19	8 x 23	12 x 23	12 x 28	12 x 28
	b	16	16	16	17	17	18	20	21	23	24	
	e	2	2	2	2	2	3	3	3	3	4	

STANDARDS :

- Fabrication according to ISO 9001 : 2015
- DIRECTIVE 2014/68/EU : CE N° 0038
Risk category III module H
- Certificate 3.1 on request
- Pressure tests according to EN 12266-1, range B
- Length according to EN 558 series 14 (DIN 3202 F4)
- Flanged R.F. according to EN 1092-2 PN16
- Design according to DIN 3352

ADVICE : Our opinion and our advice are not guaranteed and SFERACO shall not be liable for the consequences of damages. The customer must check the right choice of the products with the real service conditions.

DUCTILE IRON GATE VALVE PN16 WITH RISING STEM

INSTALLATION INSTRUCTIONS

GENERAL GUIDELINES :

- Ensure that the valves to be used are appropriate for the conditions of the installation (type of fluid, pressure and temperature).
- Be sure to have enough valves to be able to isolate the sections of piping as well as the appropriate equipment for maintenance and repair.
- Ensure that the valves to be installed are of correct strength to be able to support the capacity of their usage.
- **Installation of all circuits should ensure that their function can be automatically tested on a regular basis (at least two times a year).**

INSTALLATION INSTRUCTIONS :

- **Before installing the valves, clean and remove any objects from the pipes** (in particular bits of sealing and metal) which could obstruct and block the valves.
- **Ensure that both connecting pipes either side of the valve (upstream and downstream) are aligned (if they're not, the valves may not work correctly).**
- **Make sure that the two sections of the pipe (upstream and downstream) match, the valve unit will not absorb any gaps. Any distortions in the pipes may affect the tightness of the connection, the working of the valve and can even cause a rupture.** To be sure, place the kit in position to ensure the assembling will work.
- **If sections of piping do not have their final support in place, they should be temporarily fixed. This is to avoid unnecessary strain on the valve.**
- Tighten the bolts in cross.
- It's recommended to operate the valve (open and close) 1 to 2 times per year
- **It may be necessary to screw the packing gland during using according to the type of use.**
- **Do not use a tool to shut the valve**
- **Fluids in the valve must not contain solid objects (it could damaged the seat).**