

2 PIECES A105N BALL VALVE WITH WELDING ENDS CLASS 800

2 pieces ball valve 800lbs forged carbon steel with welding ends full bore for Chemical and Pharmaceutical industries, petrochemical industries, hydraulic installation, heating and compressed air.

Ball valve with fire safe certificate BS 67755-2 to reduce risks in case of fire.

PTFE filled with 25% Carbon seat, packing and body gasket.

Compatible with explosive atmosphere, ATEX Zone 1&21 and Zone 2&22 thanks to the double antistatic device.

Handling possible with locking device, stainless steel handle or oval hand wheel.



NACE
MR01-75

Certificate
3.1



Size : DN 8 to DN 50

Ends: Butt Welding, Socket welding or straight welding

Min Temperature : -20°C

Max Temperature : +180°C

Max Pressure : 136 Bars (Class 800)

Specifications : Anti blow-out stem, ATEX

Fire safe BS 6755-2

Antistatice device

Full bore

Materials : Forged Carbon Steel ASTM A105N

2 PIECES A105N BALL VALVE WITH WELDING ENDS CLASS 800

SPECIFICATIONS :

- Full bore
- Anti blow-out stem
- Ends 100 mm But Welding schedule 80 , or socket welding or straight welding
- Class 800
- Fire safe according to BS 6755 part.2
- Atex
- Antistatic device
- 2 pieces type
- Galvanization treatment of zinc anti-corrosion coating, 8μ thickness
- NACE MR01-75

USE :

- Chemical and pharmaceutical industries, petrochemical industries, hydraulic installation, compressed air
- Min and max Temperature Ts : - 20°C to + 180°C
- Max Pressure Ps : 136 bars
- Steam : 5 bars maximum

PRESSURE / TEMPERATURE GRAPH :

PRESSURE

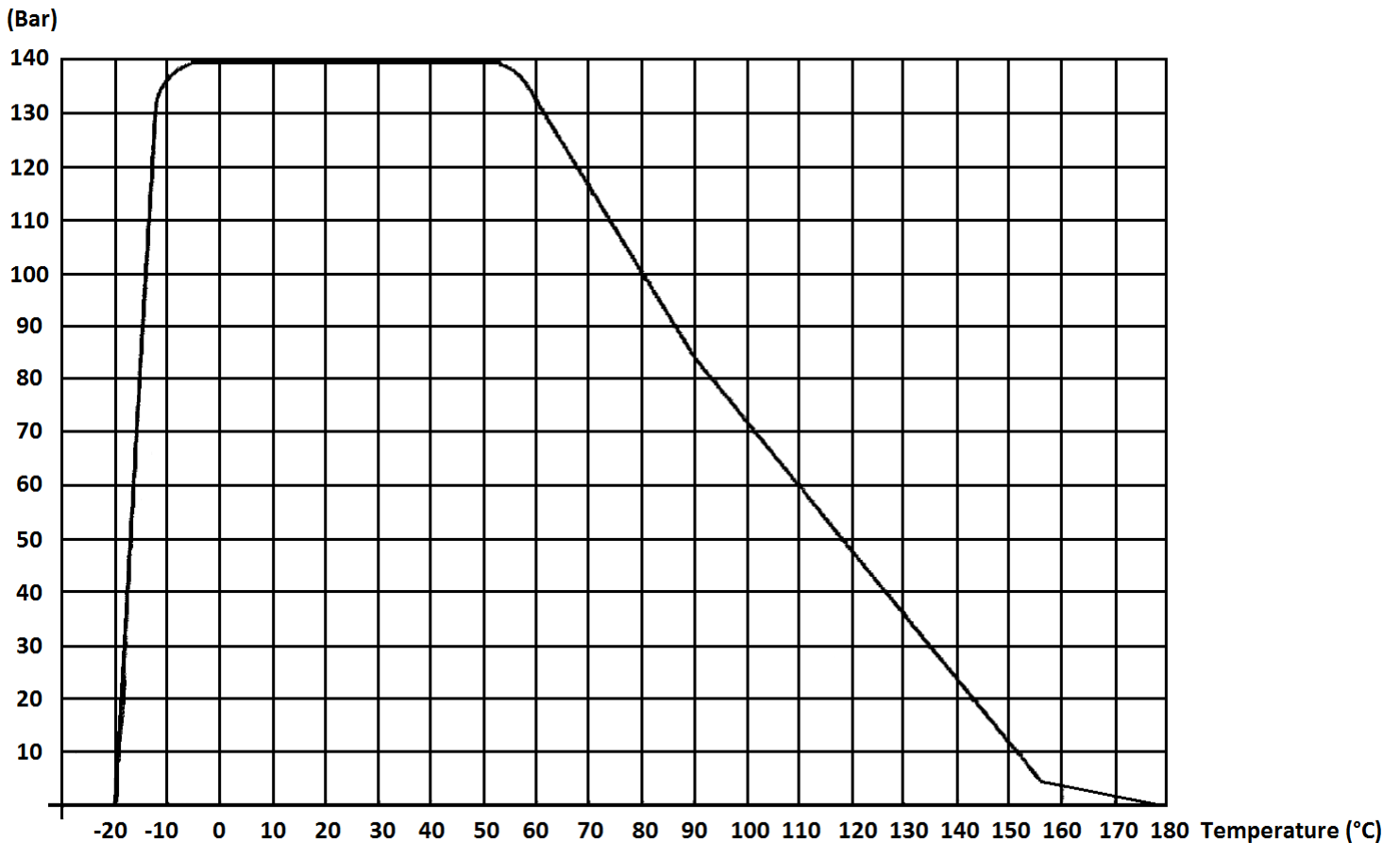

2 PIECES A105N BALL VALVE WITH WELDING ENDS CLASS 800

TORQUES VALUES (in Nm without safety coefficient) :

DN (mm)	8	10	15	20	25	32	40	50
NPS (")	1/4"	3/8"	1/2"	3/4"	1"	1"1/4"	1"1/2"	2"
Torque (Nm)	12	12	12	12	25	64	78	103

RANGE :



- Ball valve class 800 forged ASTM A105N body and welding ends **Ref. 718 / 7181 / 7182** from DN 8 to DN 50



- Stainless steel 304 with red cover handle

DN	8-10	15	20-25	32-40	50
Ref.	9830320	9830316	9830317	9830318	9830321



- Locking device (with padlock)

DN	8-10	15	20-25	32-40	50
Ref.	9830301	9830313	9830314	9830315	9830496



- Galvanized steel handwheel

DN	8-10	15	20-25	32-40	50
Ref.	9830571	9830572	9830573	9830574	

ENDS :

- Butt Welding ends schedule 80 **Ref. 718**
- Straight welding ends **Ref. 7181** (on request)
- Socket Welding ends **Ref. 7182** (on request)

2 PIECES A105N BALL VALVE WITH WELDING ENDS CLASS 800

MATERIALS BUTT WELDING ENDS TYPES 718 :

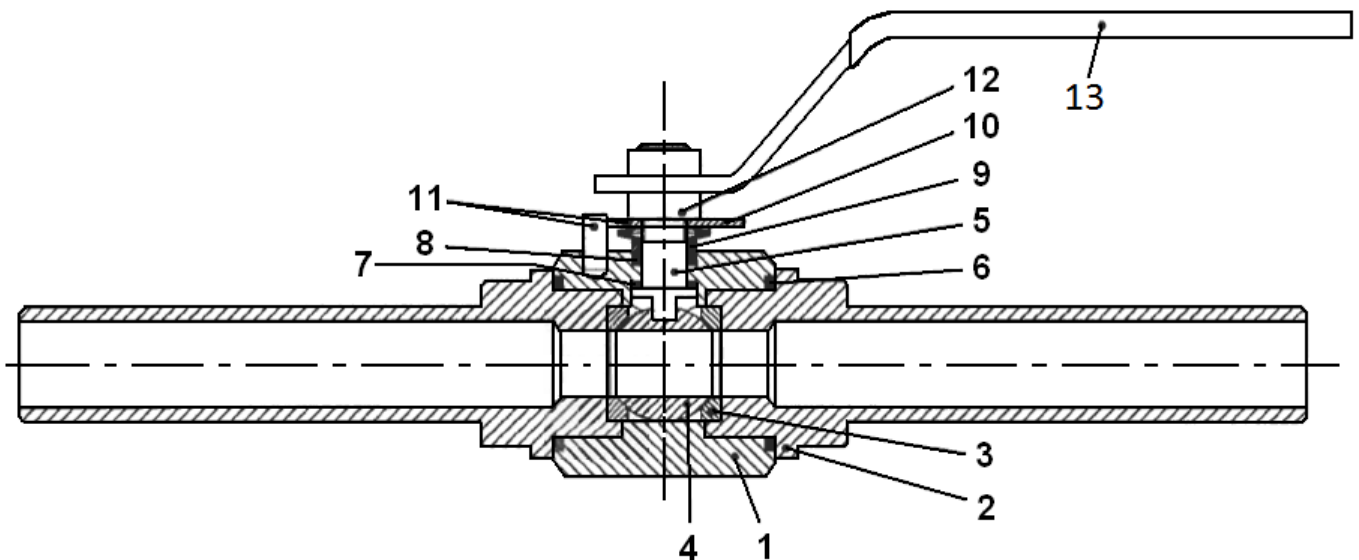

Item	Designation	Materials
1	Body	ASTM A105N
2	Ends	
3	Seat	PTFE filled with 25% carbon
4	Ball	ASTM A182 F316L
5	Stem	
6	Body gasket	PTFE filled with 25% carbon
7	Thrust washer	
8	Packing	
9	Packing gland	ASTM A105N
10	Disc springs	Galvanized steel
11	Stop	
12	Nut	
13	Handle	

2 PIECES A105N BALL VALVE WITH WELDING ENDS CLASS 800

MATERIALS STRAIGHT WELDING ENDS TYPES 7181 :

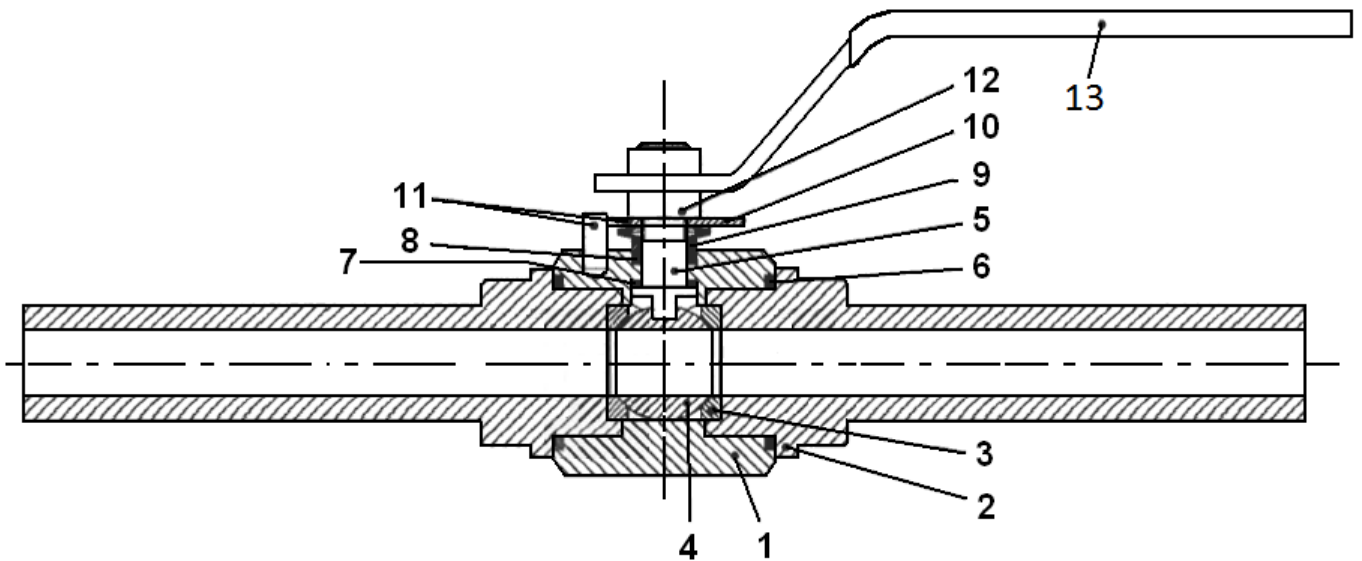

Item	Designation	Materials
1	Body	ASTM A105N
2	Ends	
3	Seat	PTFE filled with 25% carbon
4	Ball	ASTM A182 F316L
5	Stem	
6	Body gasket	PTFE filled with 25% carbon
7	Thrust washer	
8	Packing	
9	Packing gland	ASTM A105N
10	Disc springs	Galvanized steel
11	Stop	
12	Nut	
13	Handle	

2 PIECES A105N BALL VALVE WITH WELDING ENDS CLASS 800

MATERIALS SOCKET WELDING ENDS TYPES. 7182 :

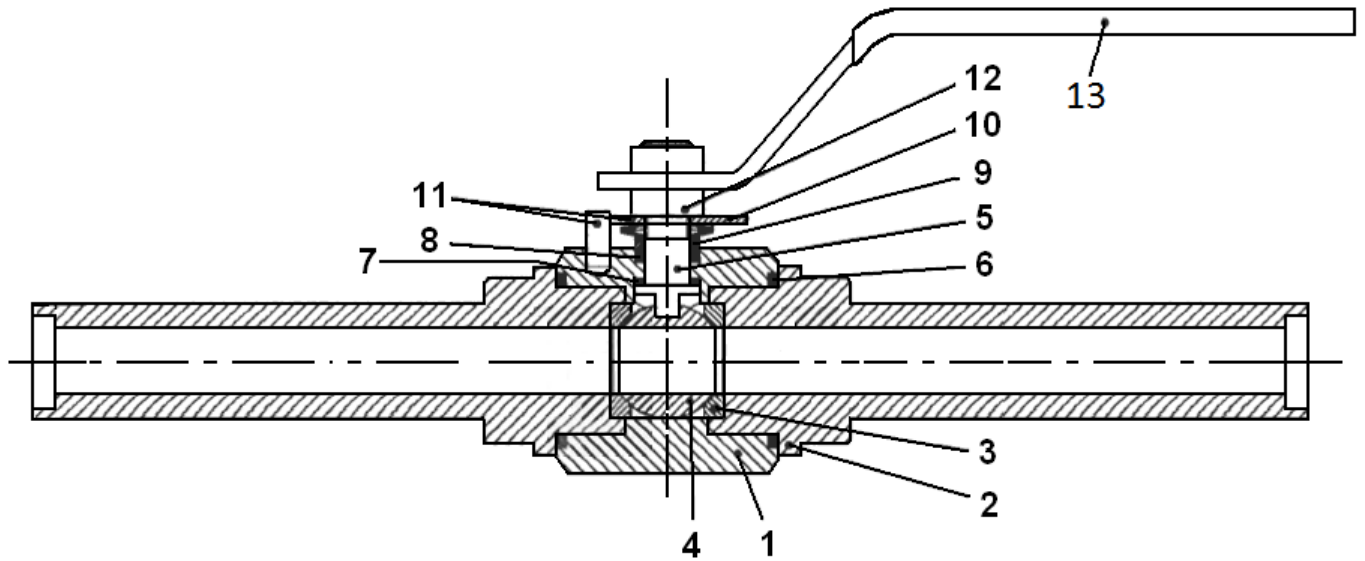

Item	Designation	Materials
1	Body	ASTM A105N
2	Ends	
3	Seat	PTFE filled with 25% carbon
4	Ball	ASTM A182 F316L
5	Stem	
6	Body gasket	PTFE filled with 25% carbon
7	Thrust washer	
8	Packing	
9	Packing gland	ASTM A105N
10	Disc springs	Galvanized steel
11	Stop	
12	Nut	
13	Handle	

2 PIECES A105N BALL VALVE WITH WELDING ENDS CLASS 800

SIZE BUTT WELDING ENDS TYPES 718 (in mm) :

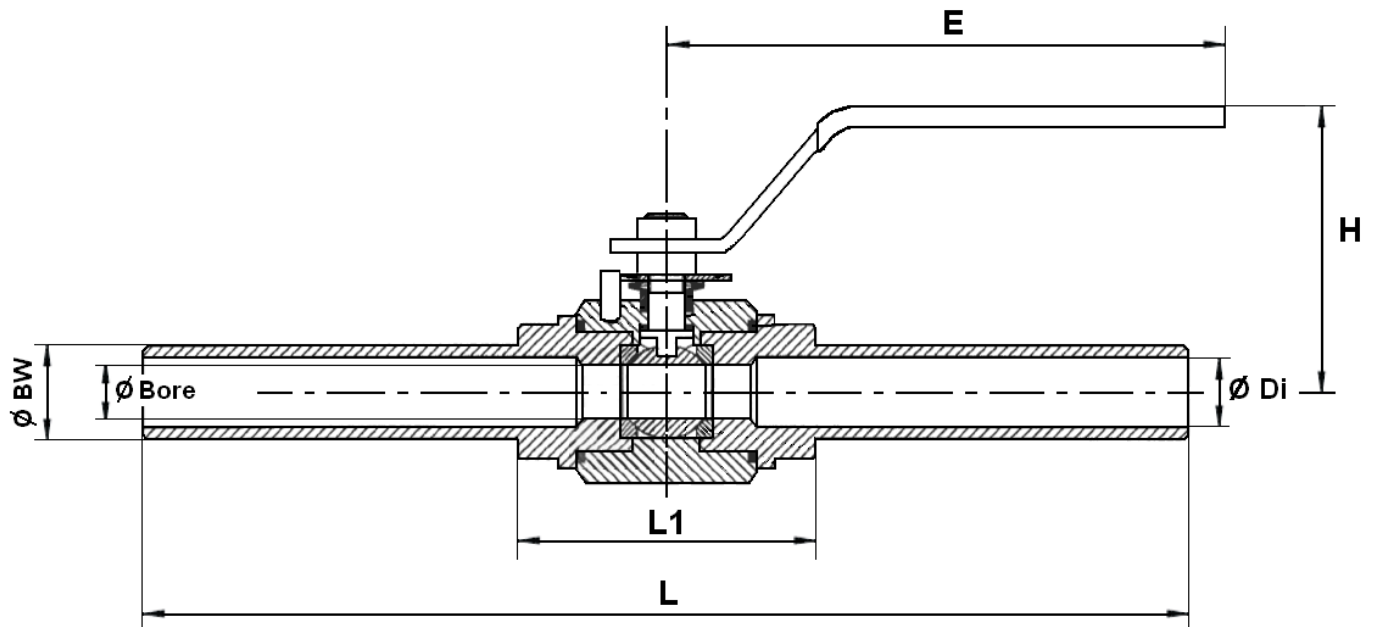

Stem size :

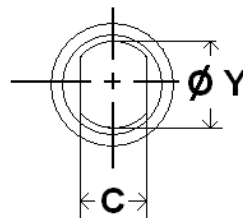

Ref.	DN	8	10	15	20	25	32	40	50
718	Ø Bore	10	10	15	20	25	30	38	48
	L	267	267	275	290	310	320	335	355
	L1	67	67	75	90	105	120	135	155
	E	148	148	148	180	180	240	240	280
	H	72	72	75	85	95	100	105	115
	Ø BW	13.5	17.2	21.3	26.7	33.4	42.2	48.3	60.3
	Ø Di	7.7	10.8	13.9	18.8	24.3	32.5	38.1	49.2
	C	5	5	5.5	7.5	7.5	9	9	9
	Ø Y	8	8	10	12	12	14	14	14
Weight (in Kg)	0.6	0.6	1	2	4	5.5	7	9	

2 PIECES A105N BALL VALVE WITH WELDING ENDS CLASS 800

SIZE STRAIGHT WELDING ENDS TYPES 7181 (in mm) :

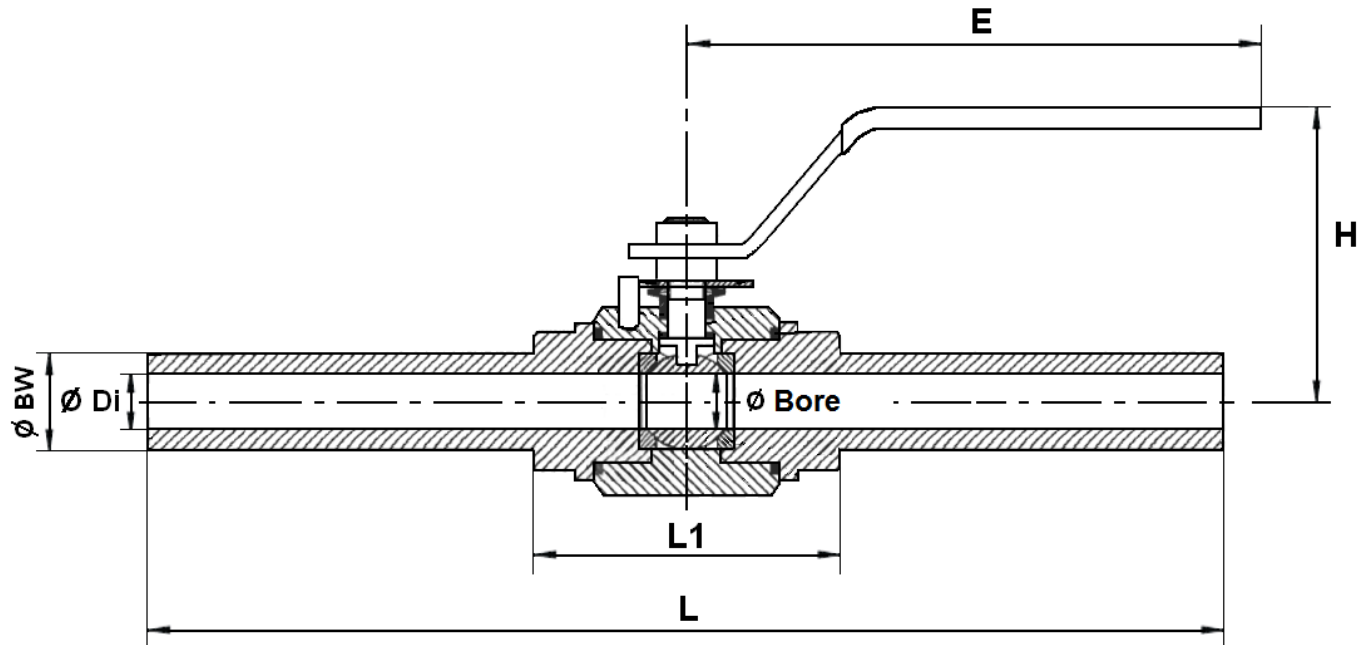

Stem size :

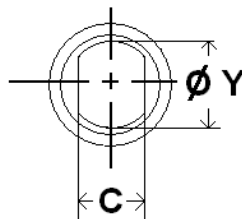

Ref.	DN	8	10	15	20	25	32	40	50
7181	Ø Bore	10	10	15	20	25	30	38	48
	L	267	267	275	290	310	320	335	355
	L1	67	67	75	90	105	120	135	155
	E	148	148	148	180	180	240	240	280
	H	72	72	75	85	95	100	105	115
	Ø BW	13.5	17.2	21.3	26.7	33.4	42.2	48.3	60.3
	Ø Di	7.7	10.8	13.9	18.8	24.3	32.5	38.1	49.2
	C	5	5	5.5	7.5	7.5	9	9	9
	Ø Y	8	8	10	12	12	14	14	14
	Weight (in Kg)	0.6	0.6	1	2	4	5.5	7	9

2 PIECES A105N BALL VALVE WITH WELDING ENDS CLASS 800

SIZE SOCKET WELDING ENDS TYPES 7182 (in mm) :

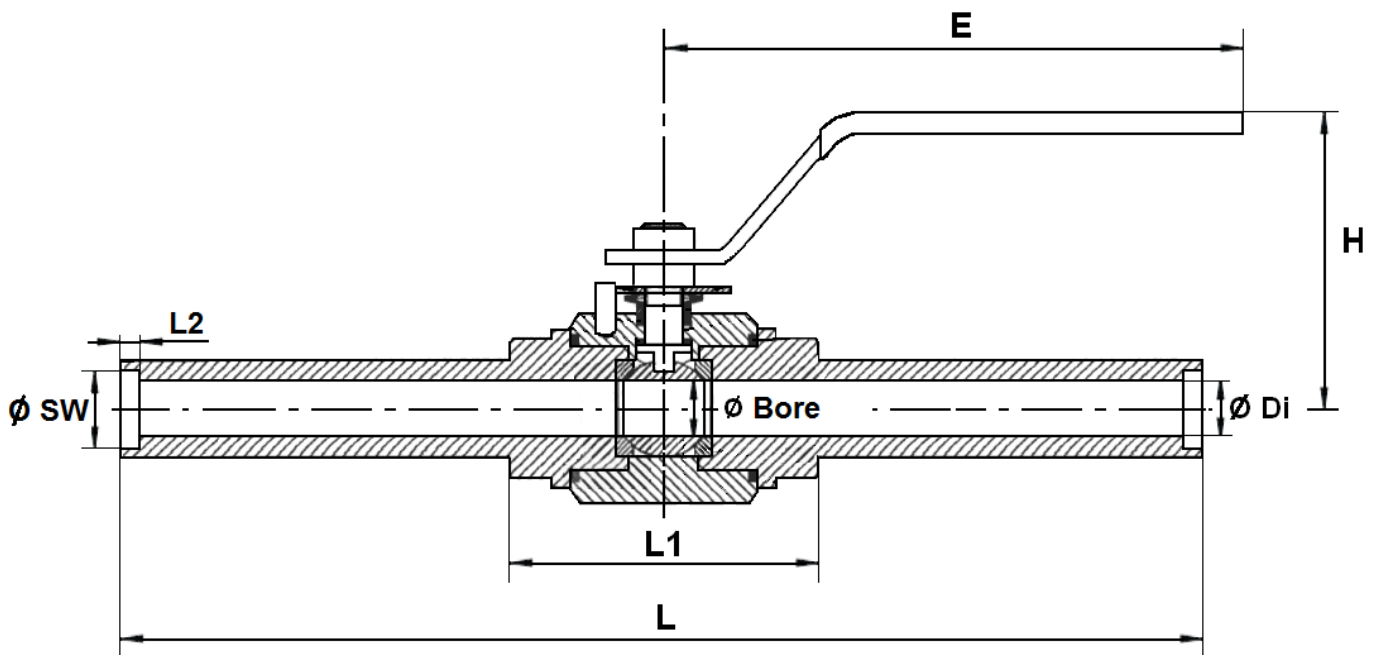

Stem size :

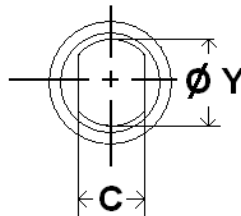

Ref.	DN	8	10	15	20	25	32	40	50
7182	Ø Bore	10	10	15	20	25	30	38	48
	L	267	267	275	290	310	320	335	355
	L1	67	67	75	90	105	120	135	155
	E	148	148	148	180	180	240	240	280
	H	72	72	75	85	95	100	105	115
	Ø SW	14.3	17.8	21.8	27.3	34	42.6	48.7	61.3
	L2	9.5	9.5	9.5	11.5	13	14	16	17
	Ø Di	7.7	10.8	13.9	18.8	24.3	32.5	38.1	49.2
	C	5	5	5.5	7.5	7.5	9	9	9
	Ø Y	8	8	10	12	12	14	14	14
Weight (in Kg)	0.6	0.6	1	2	4	5.5	7	9	

2 PIECES A105N BALL VALVE WITH WELDING ENDS CLASS 800

HANDWHEEL SIZE (in mm) :

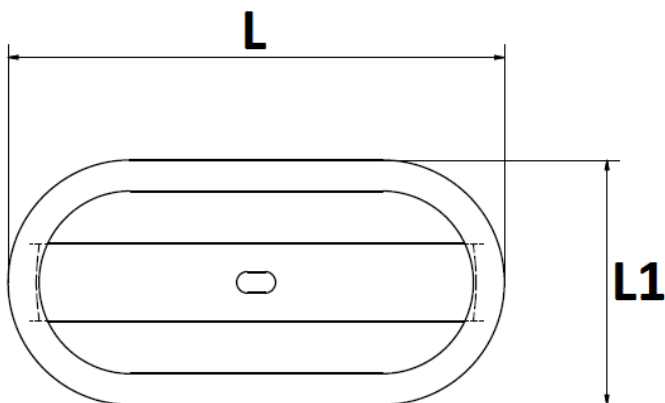
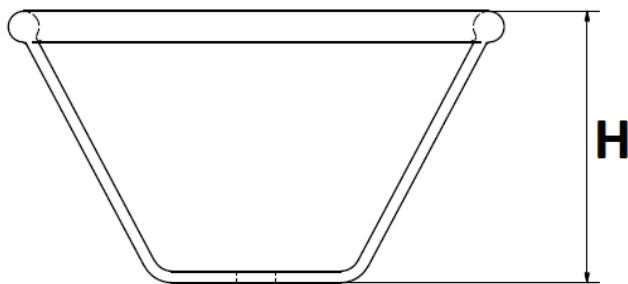

DN	1/4"	3/8"	1/2"	3/4"	1"	1"1/4"	1"1/2"	2"
H	77	70	70	69	64	77	80	80
L	130	128	133	133	130	210	205	205
L1	68	63	68	77	82	87	105	105
Ref.	9830571	9830571	9830572	9830573	9830573	9830574	9830574	9830574
Weight (in Kg)	0.300	0.300	0.380	0.420	0.420	0.460	0.460	0.460

2 PIECES A105N BALL VALVE WITH WELDING ENDS CLASS 800**STANDARDS :**

- Fabrication according to ISO 9001 : 2015
- DIRECTIVE 2014/68/EU : CE N° 0948
Risk category III Module B+C2
- Pressure tests according to API 598, table 6
- Butt Welding ends according to ANSI B16.25
- Fire safe according to B.S. 6755 part.2
- Materials according to NACE MR 01-75
- ATEX Group II Category 2 G/2D Zone 1 & 21 Zone 2 & 22 (optional marking)

ADVICE : Our opinion and our advice are not guaranteed and SFERACO shall not be liable for the consequences of damages.
The customer must check the right choice of the products with the real service conditions.