

**2 PIECES CARBON STEEL BALL VALVES FLANGED CLASS 150 PN20
PERFORMANCE RANGE**



Certificate 3.1

Size : DN 15 to 200 mm (NPS 1/2" to 8")
Ends : CLASS 150 PN20 R.F. Flanges
Min Temperature : - 20°C
Max Temperature : + 200°C
Max Pressure : 20 Bars
Specifications : ISO 5211 mounting pad
PTFE filled with 15% glass seat
Anti blow-out stem
Atex
Fire safe according to API607 up to DN200 (8")

Materials : Carbon steel ASTM A216 WCB

**2 PIECES CARBON STEEL BALL VALVES FLANGED CLASS 150 PN20
PERFORMANCE RANGE**

SPECIFICATIONS :

- Full bore
- Anti blow-out stem
- Double antistatic device
- PTFE filled with 15% glass seat
- Locking device
- ISO 5211 mounting pad
- 2 pieces type (Split body)
- Hollowed ball from DN125 to DN200
- With exhaust hole in the ball (located in the top of the ball to avoid overpressure in it)
- Primer coating for carbon steel valves

USE :

- Chemical industries, petrochemical industries, hydraulic installation, compressed air, heating and water distribution
- Steam : 11 bars maximum
- Min and max Temperatures Ts : -20°C to + 200°C
- Max Pressure Ps : 20 bars (see graph under)

PRESSURE / TEMPERATURE GRAPH (STEAM EXCLUDED) :

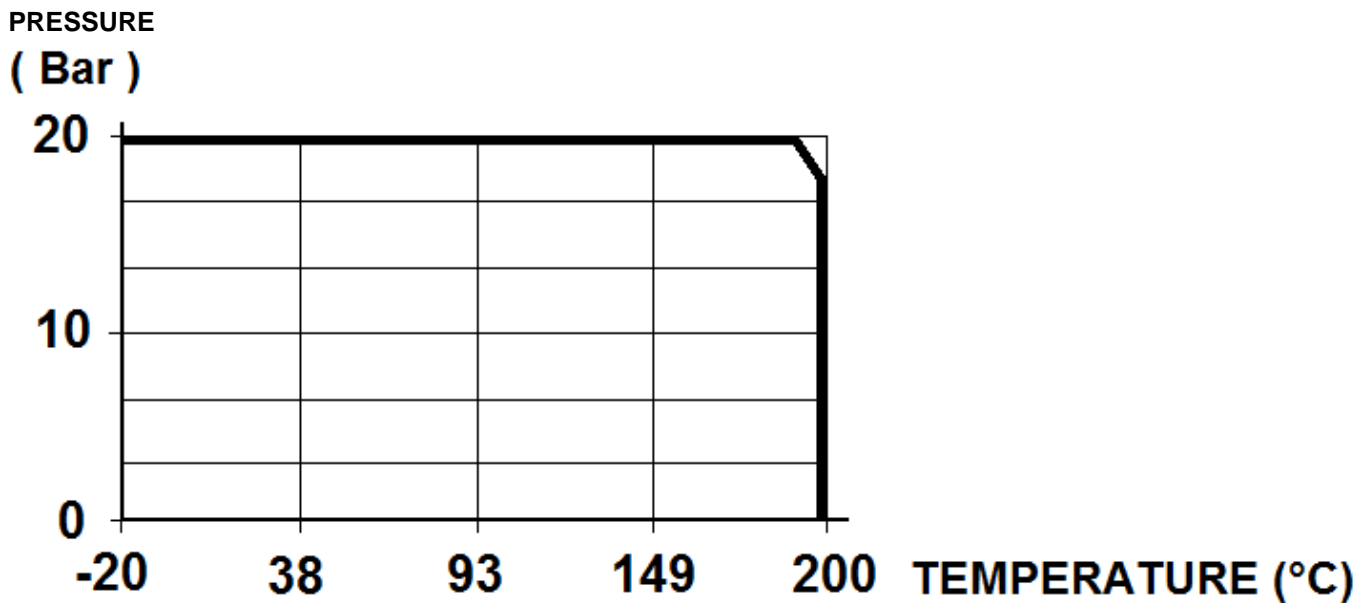

RANGE :

- 2 pieces carbon steel body valve Class 150 (PN20) **Ref. 778** from DN 15 to DN 200 (NPS 1/2" to 8")
- Gearbox possible **Ref. 9830296-9830297** from DN 150 to DN 200 (NPS 6" to 8")

ENDS :

- R.F. Flanged Class 150 (PN20)

**2 PIECES CARBON STEEL BALL VALVES FLANGED CLASS 150 PN20
PERFORMANCE RANGE**

MATERIALS DN 15 - 50 (NPS 1/2" to 2"):

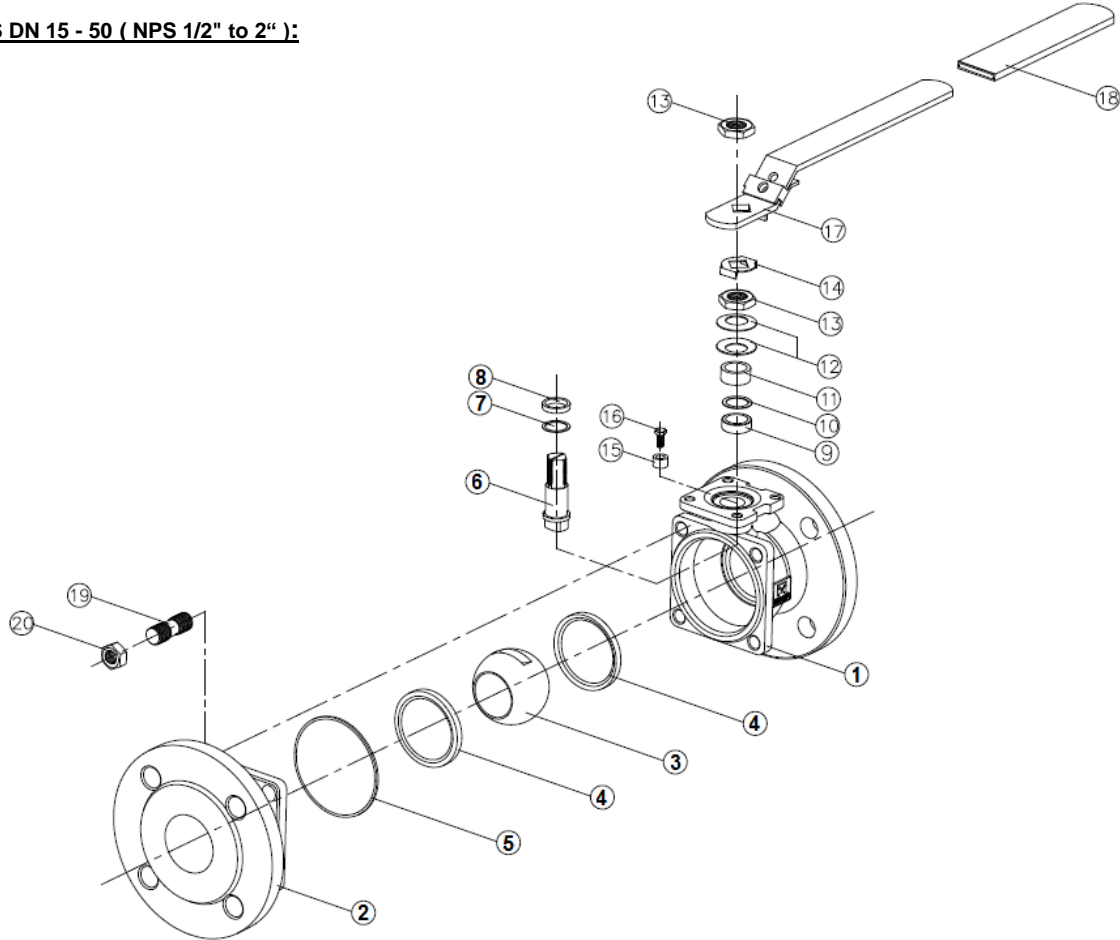

Item	Designation	Materials
1	Body	ASTM A216 WCB
2	Ends	
3	Ball	ASTM A351 CF8M
4*	Seat	PTFE filled with 15% glass
5*	Body seal	Graphite
6	Stem	ASTM A276 316
7*	Ring	PTFE filled with 25% carbon
8*	Ring	
9*	Packing	Graphite
10*	Packing	PTFE filled with 25% carbon
11	Packing gland	AISI 304
12	Elastic ring	AISI 301
13	Nut	AISI 304
14	Washer	
15	Pin	
16	Pin screw	
17	Handle	PVC
18	Handle cover	
19	Stud	AISI 304
20	Nut	

(* : included in gaskets kit)

**2 PIECES CARBON STEEL BALL VALVES FLANGED CLASS 150 PN20
PERFORMANCE RANGE**

MATERIALS DN 65 - 100 (NPS 2" 1/2 to 4"):

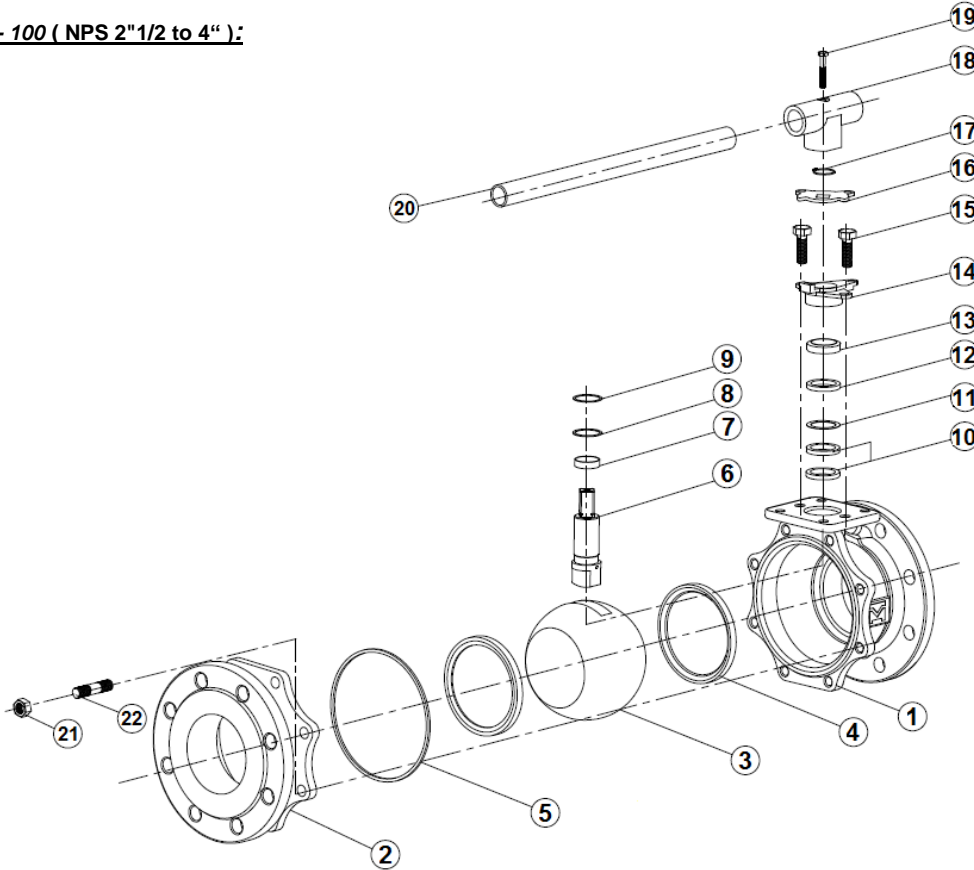

Item	Designation	Materials
1	Body	ASTM A216 WCB
2	Ends	
3	Ball	ASTM A351 CF8M
4*	Seat	PTFE filled with 15% glass
5*	Body seal	Graphite
6	Stem	ASTM A276 316
7*	Ring	PTFE filled with 25% carbon
8*	Ring	
9*	Ring	
10*	Packing	Graphite
11*	Packing	PTFE filled with 25% carbon
12	Ring	AISI 304
13	Ring	
14	Packing gland	ASTM A351 CF8
15	Packing gland screw	AISI 304
16	Pin	
17	Circlips	
18	Handle adaptor	ASTM A351 CF8
19	Screw	AISI 304
20	Handle	
21	Nut	
22	Stud	

(* : included in gaskets kit)

**2 PIECES CARBON STEEL BALL VALVES FLANGED CLASS 150 PN20
PERFORMANCE RANGE**

MATERIALS DN 125 - 200 (NPS 5" to 8"):

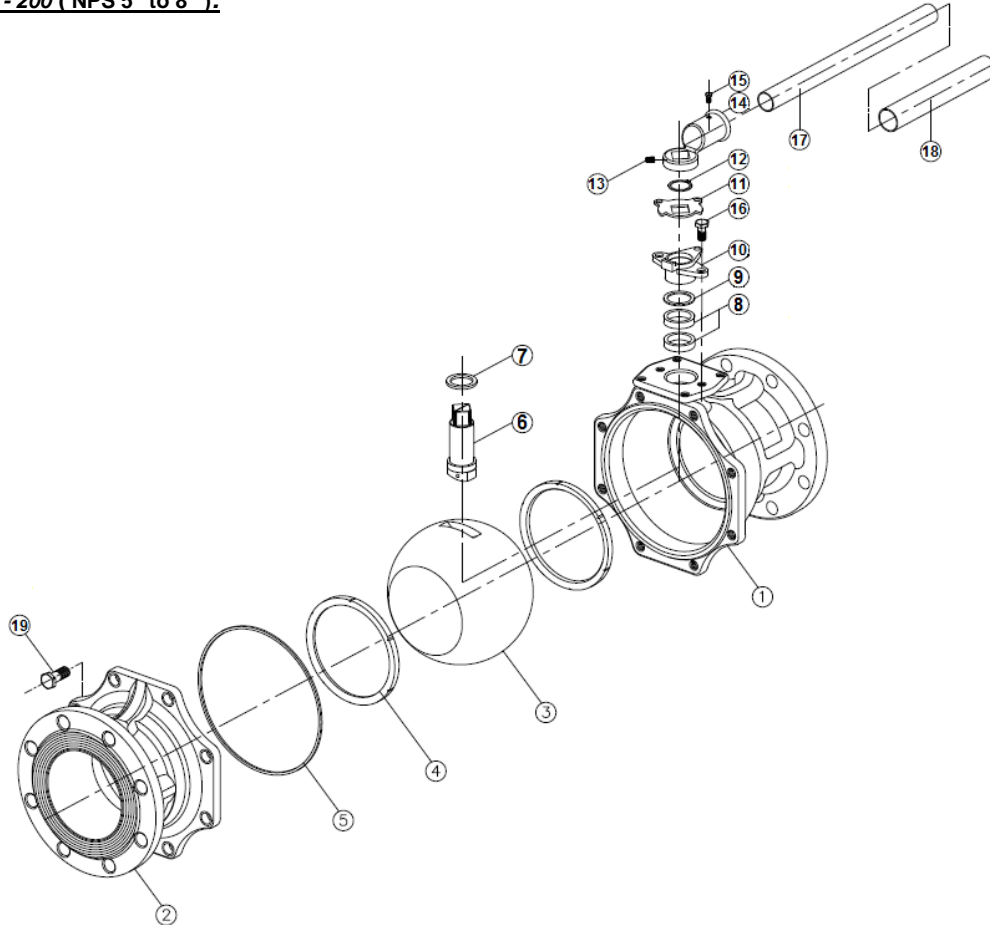

Item	Designation	Materials
1	Body	ASTM A216 WCB
2	Ends	
3	Ball	AISI 316
4*	Seat	PTFE filled with 15% glass
5*	Body seal	Graphite
6	Stem	ASTM A276 316
7*	Ring	PTFE filled with 25% carbon
8*	Packing	Graphite
9*	Packing	PTFE filled with 25% carbon
10*	Packing gland	ASTM A351 CF8
11	Pin	AISI 304
12	Circlips	
13	Screw	
14	Handle adaptor	
15	Screw	
16	Packing gland screw	
17	Handle	PVC
18	Handle cover	
19	Body screw	AISI 304

(* : included in gaskets kit)

**2 PIECES CARBON STEEL BALL VALVES FLANGED CLASS 150 PN20
PERFORMANCE RANGE**

SIZE DN 15 – 50 (NPS 1/2" to 2") (in mm) :

DN 15 – 50 (NPS 1/2" to 2")

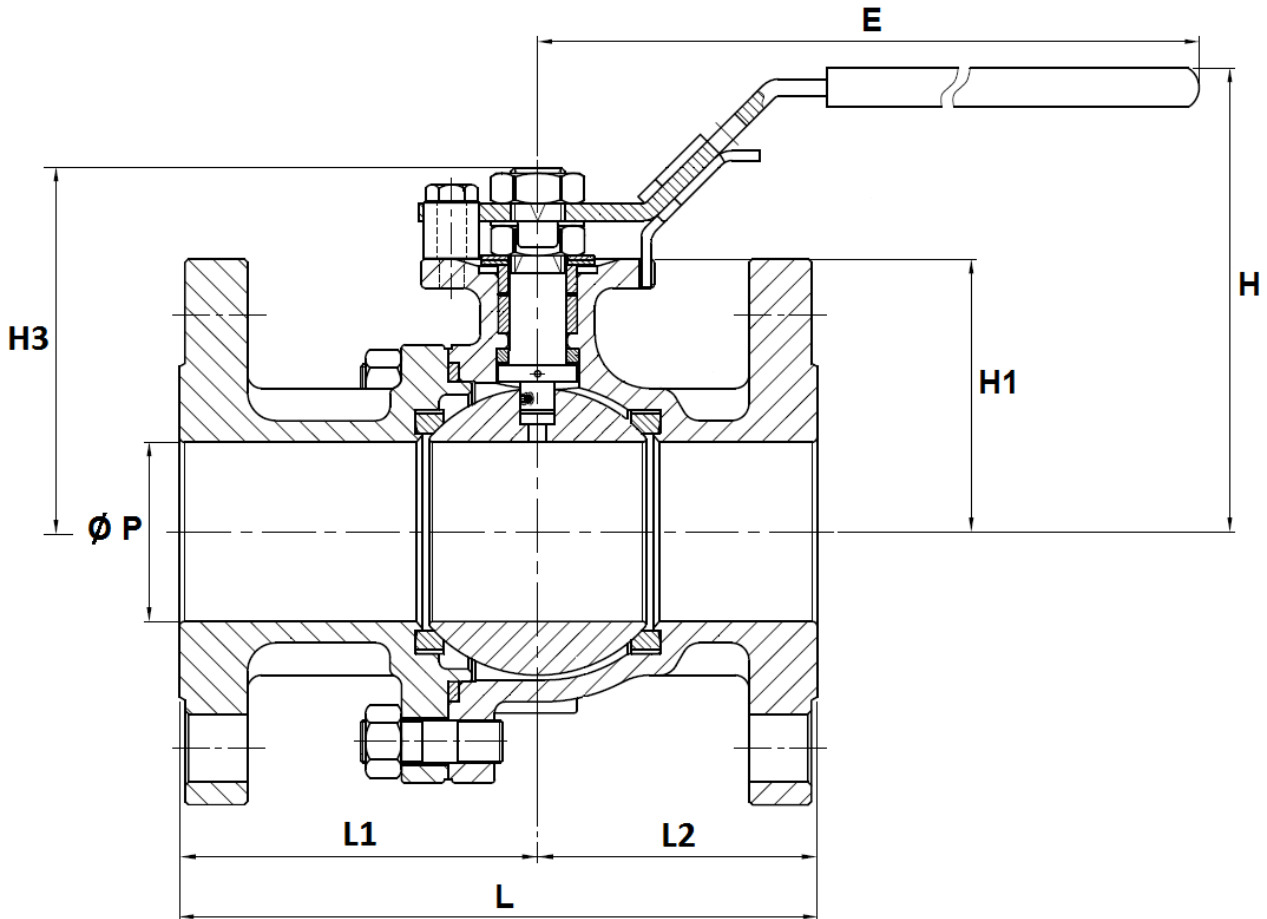

Ref.	DN (mm)	15	20	25	32	40	50
	NPS (")	1/2"	3/4"	1"	1"1/4	1"1/2	2"
778	Ø P	15	20	24	30	38	50
	L	108	117	127	140.2	165	178
	L1	61	65	72.5	78.2	90.8	98
	L2	47	52	54.5	62	74.2	80
	E	158	158	196	196	245	261
	H	76.6	79.1	92	96	121.1	127.6
	H1	39	42.5	52	56	66	73
	H3	53.5	56.5	70	73	88	94.5
	Weight (Kg)	1.9	2.4	3.4	4.2	6.1	8.8

**2 PIECES CARBON STEEL BALL VALVES FLANGED CLASS 150 PN20
PERFORMANCE RANGE**

SIZE DN 65 - 100 (NPS 2"1/2 to 4") (in mm) :

DN 65 – 100 (NPS 2"1/2 to 4")

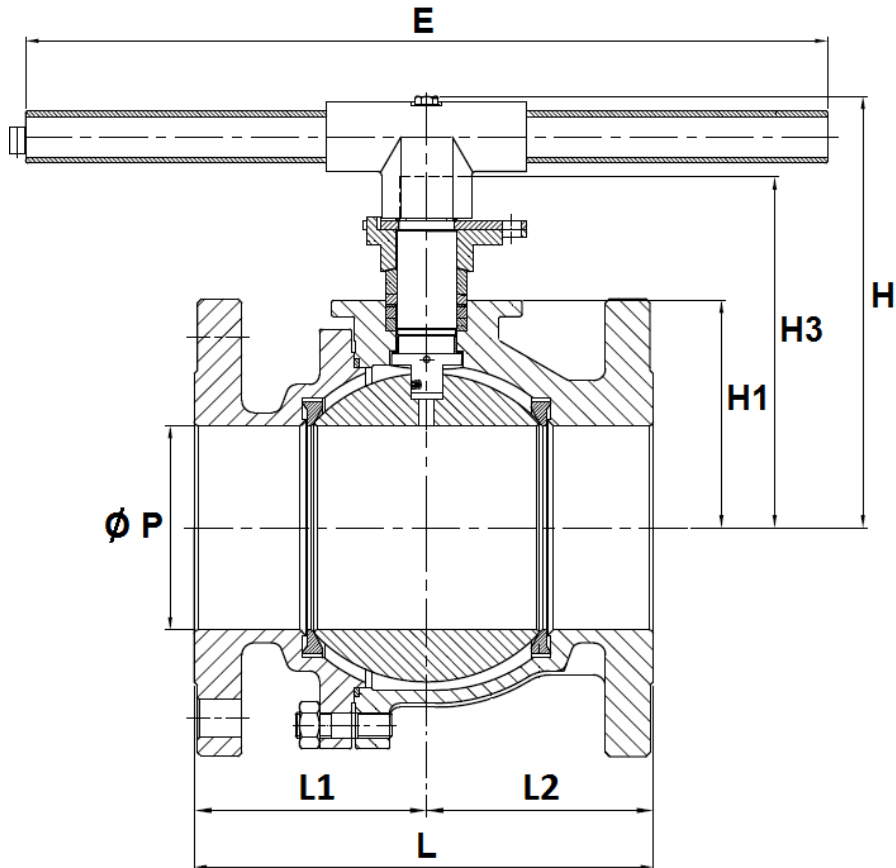

Ref.	DN (mm)	65	80	100
	NPS (")	2"1/2	3"	4"
778	Ø P	64	76	98
	L	190	203	229
	L1	100.3	109.2	119.3
	L2	89.7	93.8	109.7
	E	400	400	400
	H	188	194	215
	H1	86.5	91.5	113.5
	H3	152	158	179
	Weight (in Kg)	16.4	19.5	28.1

**2 PIECES CARBON STEEL BALL VALVES FLANGED CLASS 150 PN20
PERFORMANCE RANGE**

SIZE DN 125 - 200 (NPS 5" to 8") (in mm) :

DN 125 – 200 (NPS 5" to 8")

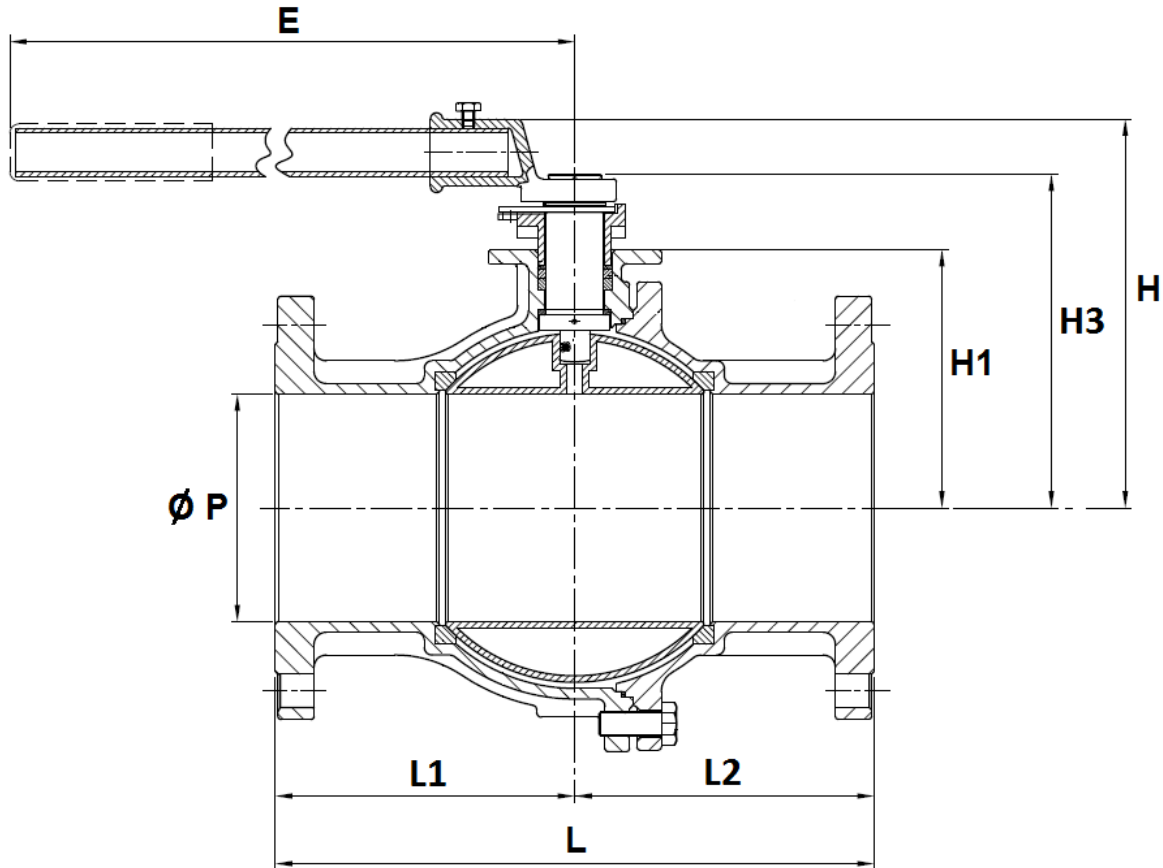

Ref.	DN	125	150	200
	NPS (")	5"	6"	8"
778	Ø P	125	150	200
	L	356	394	457
	L1	176.7	197	226
	L2	179.3	197	231
	E	743	743	840
	H	239.6	256.5	334
	H1	147	170	215
	H3	199	220	300.5
	Weight (in Kg)	40	54	88

**2 PIECES CARBON STEEL BALL VALVES FLANGED CLASS 150 PN20
PERFORMANCE RANGE**

GEARBOX SIZE (in mm) :

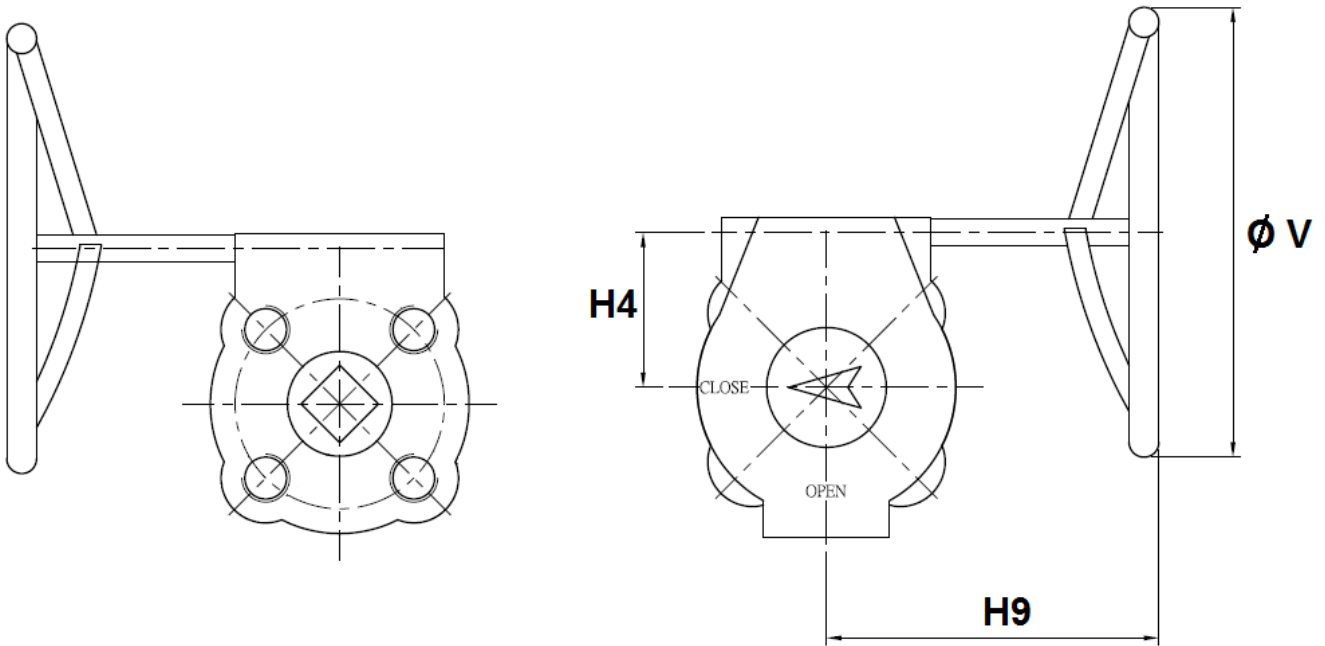

DN (mm)	150	200
NPS (")	6"	8"
H4	63	78
H9	238	226
Ø V	300	300
Weight (Kg)	12.5	15
Ref.	9830296	9830297

**2 PIECES CARBON STEEL BALL VALVES FLANGED CLASS 150 PN20
PERFORMANCE RANGE**

ISO MOUNTING PAD AND STEM SIZE (in mm) :

DN 15 – 50

DN 65 – 100

DN 125 - 200

NPS (1/2" - 2")

NPS (2"1/2 - 4")

NPS (5" - 8")

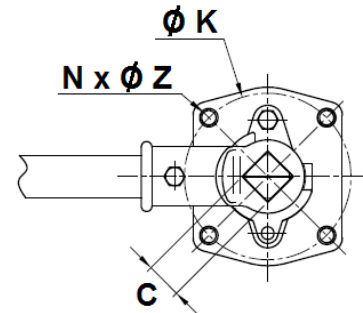
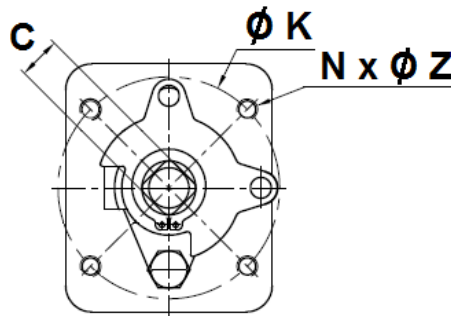
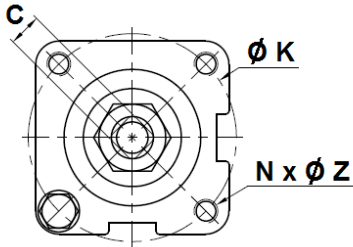
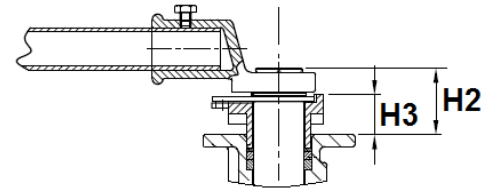
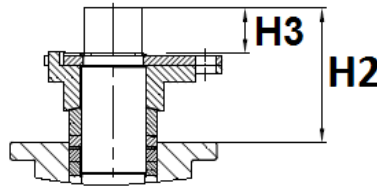
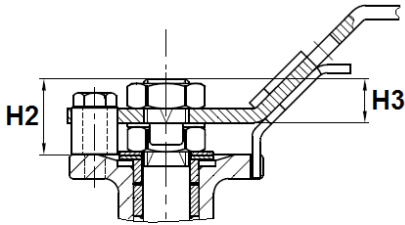

Ref.	DN (mm)	15	20	25	32	40	50	65	80	100	125	150	200
	NPS (")	1/2"	3/4"	1"	1"1/4	1"1/2	2"	2"1/2	3"	4"	5"	6"	8"
778	C	9	9	11	11	14	14	17	17	17	27	27	36
	Ø K	42	42	50	50	70	70	102	102	102	125	125	140
	ISO	F04	F04	F05	F05	F07	F07	F10	F10	F10	F12	F12	F14
	N x Ø Z	4xM5	4xM5	4xM6	4xM6	4xM8	4xM8	4xM10	4xM10	4xM10	4xM12	4xM12	4xM16
	H2	14.5	14	18	17	22	21.5	65.5	66.5	65.5	52	50	85.5
	H3	8.5	8.5	12	12	14	14	27	27	27	19	19	43.5

**2 PIECES CARBON STEEL BALL VALVES FLANGED CLASS 150 PN20
PERFORMANCE RANGE**

CLASS 150 (PN20) FLANGES SIZE (in mm) :

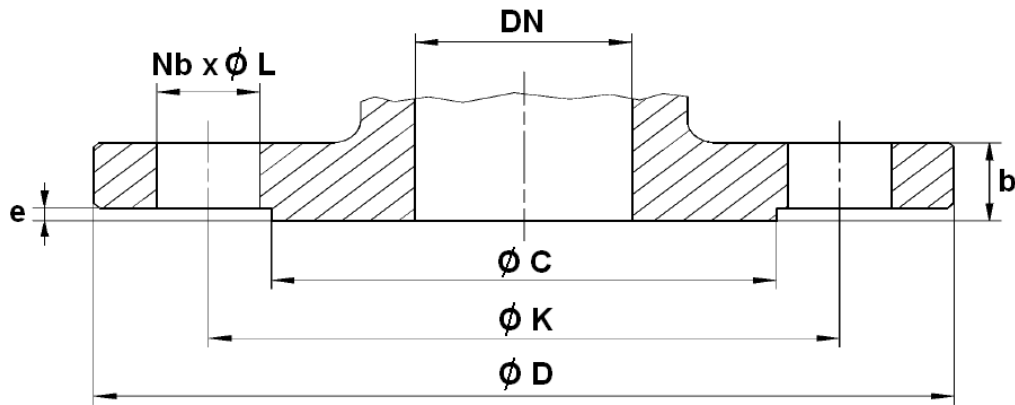

Ref.	DN (mm)	15	20	25	32	40	50	65	80	100	125	150	200
	NPS (")	1/2"	3/4"	1"	1"1/4	1"1/2	2"	2"1/2	3"	4"	5"	6"	8"
778	Ø C	35	42.9	50.8	63.5	73	92.1	104.8	127	157.2	186	216	270
	Ø D	90	100	110	115	125	150	180	190	230	254	279	343
	Ø K	60.3	69.9	79.4	88.9	98.4	120.7	139.7	152.4	190.5	216	241.5	298.5
	Nb x Ø L	4 x 15.8	4 x 15.8	4 x 15.8	4 x 15.8	4 x 15.8	4 x 19	4 x 19	4 x 19	8 x 19	8 x 22	8 x 22	8 x 22.5
	b	11.2	12.7	14.3	15.9	17.5	19	22.3	23.9	23.9	23.9	25.4	28.6
	e	1.6	1.6	1.6	1.6	1.6	1.6	1.6	1.6	1.6	1.6	1.6	1.6

2 PIECES CARBON STEEL BALL VALVES FLANGED CLASS 150 PN20 PERFORMANCE RANGE

FLOW COEFFICIENT Kvs (M3 / h) :

DN	15	20	25	32	40	50	65	80	100	125	150	200
NPS (")	1/2"	3/4"	1"	1"1/4	1"1/2	2"	2"1/2	3"	4"	5"	6"	8"
Kvs (m3/h)	31	58	86	139	229	415	698	983	1686	2824	3953	7225

TORQUE VALUES (in Nm without safety coefficient) :

DN (mm)	15	20	25	32	40	50	65	80	100	125	150	200
NPS (")	1/2"	3/4"	1"	1"1/4	1"1/2	2"	2"1/2	3"	4"	5"	6"	8"
Torque (Nm)	8	10	12	20	30	40	60	90	130	160	250	500

GEARBOX SPECIFICATIONS :

DN (mm)	150	200
NPS (")	6"	8"
Ref.	9830296	9830297
Ratio factor	30 :1	50 :1
Output torque (Nm)	700	1200

STANDARDS :

- Fabrication according to ISO 9001 : 2015
- DIRECTIVE 2014/68/EU : CE N° 0035
Risk Category III Module H
- Certificate 3.1 on request
- Construction according to ASME B16.34
- Pressure tests according to API 598, table 6
- Class 150 (PN20) R.F. flanges according to ASME B16.5
- ISO 5211 mounting pad
- Length according to ASME B16.10 (EN 558 series 3 up to DN100, series 12 from DN125 to 200)
- ATEX Group II Category 2 G/2D Zone 1 & 21 Zone 2 & 22 (optional marking)
- Fire safe according to API 607 6th Edition 2010 up to DN200 (8")



**2 PIECES CARBON STEEL BALL VALVES FLANGED CLASS 150 PN20
PERFORMANCE RANGE**

INSTALLATION INSTRUCTIONS

GENERAL GUIDELINES :

- Ensure that the valves to be used are appropriate for the conditions of the installation (type of fluid, pressure and temperature).
- Be sure to have enough valves to be able to isolate the sections of piping as well as the appropriate equipment for maintenance and repair.
- Ensure that the valves to be installed are of correct strength to be able to support the capacity of their usage.
- **Installation of all circuits should ensure that their function can be automatically tested on a regular basis (at least two times a year).**

INSTALLATION INSTRUCTIONS :

- **Before installing the valves, clean and remove any objects from the pipes** (in particular bits of sealing and metal) which could obstruct and block the valves.
- **Ensure that both connecting pipes either side of the valve (upstream and downstream) are aligned (if they're not, the valves may not work correctly).**
- **Make sure that the two sections of the pipe (upstream and downstream) match, the valve unit will not absorb any gaps. Any distortions in the pipes may affect the tightness of the connection, the working of the valve and can even cause a rupture. To be sure, place the kit in position to ensure the assembling will work.**
- **If sections of piping do not have their final support in place, they should be temporarily fixed. This is to avoid unnecessary strain on the valve.**
- Tighten the bolts in cross.
- It's recommended to operate the valve (open and close) 1 to 2 times per year